



Actran 2023.1

User's Guide ActranVI

Unified Graphical User Interface
for Pre and Post-Processing

ACTRANVI 2023.1 User's Guide

Hexagon AB and/or its subsidiaries
[hexagon.com](https://www.hexagon.com)

March 24, 2023

Hexagon
Axis Park Louvain-la-Neuve
9 rue Emile Francqui
B-1435 Mont-Saint-Guibert
Belgium

Tel: +32 10 45 12 26
Fax: +32 10 45 46 26

Worldwide Web

hexagon.com

Support

<https://simcompanion.hexagon.com/>

Disclaimer and Notices

This documentation, as well as the software described in it, is furnished under license and may be used only in accordance with the terms of such license.

Hexagon reserves the right to make changes in specifications and other information contained in this document without prior notice.

The concepts, methods, and examples presented in this text are for illustrative and educational purposes only, and are not intended to be exhaustive or to apply to any particular engineering problem or design. Hexagon assumes no liability or responsibility to any person or company for direct or indirect damages resulting from the use of any information contained herein. User Documentation: Copyright © 2023 Hexagon AB and/or its subsidiaries. All rights reserved.

This notice shall be marked on any reproduction of this documentation, in whole or in part. Any reproduction or distribution of this document, in whole or in part, without the prior written consent of Hexagon is prohibited.

This software may contain certain third-party software that is protected by copyright and licensed from third party licensors. Additional terms and conditions and/or notices may apply for certain third party software. Such additional third party software terms and conditions and/or notices may be set forth in documentation and/or at <http://www.mscsoftware.com/thirdpartysoftware> (or successor website designated by Hexagon from time to time).

The Hexagon logo, Hexagon, MSC, Actran are trademarks or registered trademarks of Hexagon AB and/or its subsidiaries in the United States and/or other

countries. All other trademarks are the property of their respective owners.

Contents

I	Getting started with ACTRANVI	15
1	ACTRAN in a Nutshell	17
2	Introduction to ACTRAN Release 2023.1	21
2.1	Introduction	21
2.2	Major new features of Release 2023.1	22
3	Documentation and Support	27
3.1	Overview of the documentation	27
3.2	How to get support	29
4	ACTRAN Installation	31
4.1	Supported platforms and 's Lifecycle	31
4.2	Online download of ACTRAN	32
4.3	Setting Up ACTRAN	32
4.4	Setting up the ACTRAN licensing server	33
4.5	Advanced - Parallel version	33
4.6	Installation Directory	33
5	Launching ACTRANVI	35

5.1	Introduction	35
5.2	Screen resolution requirements	35
5.3	OpenGL requirements	35
5.4	Syntax of the command line	36
5.5	Launching the ACTRAN Launcher	37
5.6	Remarks and Further Reading	37
6	A Guided Example - Horn Model	41
6.1	Introduction	41
6.2	Overview of the Graphical User Interface	41
6.3	Pre-processing	42
6.4	Launch the computation	64
6.5	Post-processing	65
II	ACTRANVI Reference Guide	83
7	ACTRANVI Unified Interface	85
7.1	Introduction	85
7.2	The applications notebook panel	86
7.3	The Console/InfoFrame panel	86
8	ACTRANVI Menu	87
8.1	"File" menu	87
8.2	"View" menu	91
8.3	"Add" menu	92
8.4	"Tools" menu	93
8.5	"Utilities" menu	99

8.6	"Window" menu	99
8.7	"Wizards" Menu	100
8.8	"Help" menu	102
8.9	Settings	104
9	ACTRANVI Render Window	115
9.1	Mouse and Keyboard Render Window Controls	116
9.2	Render Window Controls	116
9.3	Viewport	117
9.4	Remarks and Further Reading	122
10	ACTRANVI Data Trees	123
10.1	Data Tree Node	124
10.2	Property Window	131
10.3	Topologies Tree	141
10.4	Materials	160
10.5	Tables	164
10.6	ACTRAN Analysis	168
10.7	Utility Analysis	192
10.8	Visual	193
11	ACTRANVI Toolbox	195
11.1	"Mesh" tab	196
11.2	"Import results" tab	208
11.3	"Display results" tab	213
11.4	"Run" tab	223
11.5	Console and Info frame	225

11.6	BC_MESH split utility	226
11.7	BC_MESH mode contribution utility	227
11.8	Poles Fitting utility - DGM Porous Materials	228
11.9	Poles Fitting utility - DGM Surface Conditions	229
12	Selection Tools	233
12.1	Selection Handling	233
12.2	Picking options panel	237
13	ActranVI Meshing tools	245
13.1	Meshing tools general information	245
13.2	Key concepts	249
13.3	Creation tools	251
13.4	Edit tools	257
13.5	Edge tools	260
13.6	Surface tools	262
13.7	Volume tools	274
13.8	Transform tools	280
13.9	Other tools	283
14	ACTRANVI Unit Systems	287
14.1	Introduction	287
14.2	Unit system levels	287
14.3	Unit display	291
14.4	Unit conversion	292
14.5	Compatibility with the keywords LENGTH_UNIT and MASS_UNIT	295

15	ACTRANVI Material Encryption	297
15.1	Introduction	297
15.2	Encryption settings	297
15.3	Encrypt a material used inside the analysis	299
15.4	Export a material in an encrypted format	300
15.5	Limitations	300
III PLTVIEWER Reference Guide		301
16	PLTVIEWER Overview	303
16.1	Introduction	303
16.2	Launching the PLTVIEWER	304
17	PLTVIEWER Menu	307
17.1	"File" menu	307
18	PLTVIEWER Data Trees	313
18.1	Introduction	313
18.2	Content of the Data Tree	313
18.3	Reverse Set	316
18.4	PLT Merge	317
18.5	Generate Audio File	318
18.6	Convolution	321
18.7	Plot Power Balance	322
18.8	Write PLT set	323
18.9	Apply functions to the imported data	323
18.10	Change unit system of a PLT set	324

19	PLTVIEWER Function Panel	325
19.1	Introduction	325
19.2	Function Definition	325
19.3	Built-in functions	328
19.4	Octave operators	330
 20	 PLTVIEWER Render Window	 339
20.1	Introduction	339
20.2	Handling functions to plot	340
20.3	Curves	340
20.4	Figures	343
20.5	Remarks and Further Reading	352
 21	 PLTVIEWER Sound Quality metrics	 355
21.1	Introduction	355
21.2	Bark scale	356
21.3	Loudness (ISO 532B)	356
21.4	Sharpness (DIN 45692)	356
21.5	Roughness (Daniel and Weber)	357
21.6	Tone-to-Noise Ratio / Prominence Ratio (ECMA 74)	357
21.7	Speech Intelligibility Index (ANSI S3.5)	358
 IV	 WATERFALLVIEWER Reference Guide	 359
 22	 WATERFALLVIEWER Overview	 361
22.1	Introduction	361
22.2	Launching the WATERFALLVIEWER	362

23	WATERFALLVIEWER Menu	365
23.1	"File" menu	365
23.2	"Tools" menu	368
 24	 WATERFALLVIEWER Data Trees	 393
24.1	Introduction	393
 25	 WATERFALLVIEWER Function Panel	 395
25.1	Introduction	395
25.2	X and Y Vectors	395
25.3	Z Table	397
25.4	Function Definition	397
25.5	Remarks and Further Reading	399
 26	 WATERFALLVIEWER Render Window	 401
26.1	Introduction	401
26.2	Waterfall Panel	401
26.3	Horizontal and Vertical Plot Panel	403
26.4	Figure Properties Panel	403
 V	 Sessions and Scripting	 405
 27	 Sessions	 407
27.1	Purpose	407
27.2	Save Sessions	407
27.3	Load Sessions	408
27.4	Restrictions	409

27.5	Remarks and Further Reading	409
28	Scripting	411
28.1	Introduction	411
28.2	Unified interface	412
28.3	How to get help within the console	412
28.4	Remarks and Further Reading	415
29	ACTRANVI API	417
29.1	Main ACTRANVI pre-processing functions	417
29.2	Main ACTRANVI post-processing functions	417
30	PLTVIEWER API	421
30.1	Access to results within ACTRAN results file	421
30.2	Main PLTVIEWER functions	423
31	WATERFALLVIEWERAPI	427
VI	Index	429

Part I

Getting started with ACTRANVI

ACTRAN in a Nutshell

ACTRAN is a general purpose finite element program for modelling sound propagation, transmission and absorption in an acoustic, vibro-acoustic or aero-acoustic context. ACTRAN is characterized by:

- a large material library:
 - acoustic fluid;
 - thin acoustic layer and narrow tubes (or channels) including visco-thermal effects;
 - visco-elastic solids, solid shells, thin shells and beams;
 - incompressible solids;
 - composite materials;
 - lumped mass and springs (discrete structural elements);
 - rigid porous, lumped porous and poro-elastic materials (Biot theory);
- a complete element library:
 - linear and quadratic;
 - 2D, 3D and axisymmetric;
 - standard volume elements and special *transverse* elements for the accurate modelling of special configurations: shells, stiffeners, thin acoustic layers, ...
 - conjugated infinite elements or adaptive PML elements for acoustic radiation;
- a rich set of boundary conditions, operating conditions and sources:

- acoustic sources;
 - incident and free duct modes for rotating machines;
 - pressure, velocity, acceleration and admittance boundary conditions;
 - kinematical excitations : imposed displacements and rotations;
 - mechanical excitations : point load, distributed load, distributed pressure, moments;
 - in-build models of real-life excitations : incident diffuse sound field or various models of turbulent boundary layer;
 - interface with the leading structural FEA software packages (NASTRAN, ANSYS and ABAQUS) for the import of dynamical results;
 - interface with the leading CFD software packages (among others: FLUENT, STAR-CD and CFX) for the import of the heterogeneities of the acoustic medium and the computation of the aero-acoustic sources;
 - volume-based and surface-based aerodynamic source terms (Lighthill's and Möhring's analogies) for analyzing broad-band noise generation by turbulent flows;
- several unique features (non exhaustive list):
 - sound propagation and absorption in a non-uniformly moving fluid;
 - sound propagation in non-isothermal conditions;
 - sound propagation in rotating acoustic components;
 - sound propagation taking into account visco-thermal losses occurring in thin air layers, tubes or arbitrarily-shaped cavities;
 - random acoustics in both modal and physical coordinates;
- multiple calculation procedures:
 - direct frequency response analysis;
 - modal frequency response analysis using existing ACTRAN, ANSYS or NASTRAN normal modes;
 - compressible flow analysis;
 - modal extraction;
- various solution strategies:
 - restart capability;
 - multiple load capability;
 - strong or weak vibro-acoustic coupling;
 - multi-level sequence tree to avoid unnecessary re-computations;
 - hybrid Modal/Physical approaches;

- in-core and out-of-core solvers supporting sequential and parallel (SMP and DMP) computer architectures;
- fast frequency response synthesis using the KRYLOVKRYLOV solver.

All the ACTRAN features are seamlessly integrated in ACTRANVI, the dedicated pre-post processing tool for ACTRAN.

Introduction to ACTRAN Release 2023.1

Contents

2.1	Introduction	21
2.2	Major new features of Release 2023.1	22

2.1 Introduction

Dear ACTRAN Users,

Hexagon AB and its subsidiaries is very proud to introduce the ACTRAN Release 2023.1. Indeed, some major improvements are included in this revision. Please refer to the next sections for more details. The new features and bug fixes of ACTRAN DGM are presented in the dedicated section of the ACTRAN DGM manual.

2.1.1 Important note concerning this release

- ACTRAN 2023.1 supports the operating systems below:
 - RedHat-7
 - RedHat-8
 - Suse-12¹
 - Suse-15
 - Windows-10

¹Please note that GPU acceleration is not supported anymore on the Suse-12 operating system.

– Windows-11

Further information can be found at <https://hexagon.com/support-success/manufacturing-intelligence/design-engineering-support/platform-support>.

2.2 Major new features of Release 2023.1

2.2.1 Vibroacoustics

Inverse method for equivalent sources computation

A new analysis type has been introduced in this release, the EQUIVALENT_BC_ANALYSIS, to compute the equivalent amplitudes of any set of loadings from a target output file, which can contain pressure at local microphones, or sound power levels from different panels. This analysis is compatible with both acoustic and structural loadings. It provides a framework to represent complex sources in simplified form in terms of equivalent boundary conditions, and facilitates easy exchange of information across teams without the need to share detailed models.

Improvements in the Nastran super-elements based Virtual SEA workflow

Several key improvements have been added to the Nastran super-elements based Virtual SEA workflow. First, multi-processes runs are now supported, activated by the `--dmp` and `--smp` keywords in the launch command line. The Actran and Nastran parallelism can also be differentiated with the four keywords `--nastran_smp`, `--nastran_dmp`, `--actran_smp`, `--actran_dmp`. The Nastran assembly phase can also be independently parallelized with the `--nastran_dmp_assembly` command. Secondly, new structural connection cards are now supported, namely CBEAM and CELAS2, allowing to solve more realistic models.

Represent acoustic trims as Insertion Loss (IL) in Virtual SEA

A new interface type (INSERTION_LOSS) has been added in Virtual SEA analysis. It allows to represent an acoustic trim in between a couple of structure and cavity subsystems by only specifying its Insertion Loss (IL). The fluid-structure Coupling Loss Factor (CLF) will be scaled by this insertion loss. This allows to define acoustic trims with minimal information, without specifying the material properties and thicknesses of each layer.

Output requests in Virtual SEA

OUTPUT_REQUEST datablocks can now be specified in Virtual SEA analysis. This allows to output easily local quantities. The available quantities for structural subsystems are (squared) displacement, (squared) velocity, (squared) acceleration and (squared) Gacceleration. The available quantity for acoustic subsystems is (squared) pressure.

Field maps in Virtual SEA

Output field maps can now be requested in Virtual SEA analysis, with the same setup as in Direct Frequency Response. Those field maps will display spatially dependent results (such as pressure, displacements, accelerations,...) from subsystem-wise energies, which are spatially distributed based of the available modes shapes.

Virtual SEA: support of ANSYS modes and matrices

In addition to Actran and Nastran, the Ansys modes (.rst) and matrices (.emat) can now be used in Virtual SEA analysis, extending the support of compatible modal extraction solvers. They can be used both for MODAL_ACOUSTIC and MODAL_ELASTIC components.

Output folder for Direct Frequency Response analysis

A new option has been added for Direct Frequency Responses, allowing to write all the files produced by the ACTRAN computation in a specified folder. This allows to keep the working directory clean, and find files more easily when several runs are done. For a command line launch, this new option can be used by adding the " --run_dir=output_folder" option, where output_folder is the name of the created folder that will contain all the produced files. It can also be activated for simulations launched from ACTRANVI by activating the "run in a new folder" option, available in the settings.

Pass-by Noise Workflow: Possibility to correlate sources

This new release of ACTRAN brings the possibility to assign each acoustic source of the pass-by noise workflow to a certain group. Sources within a group are correlated, meaning that their phase is considered when they are combined, which is important to have correct results for tonal noise. Uncorrelated sources (which are in different groups) are combined discarding their phase, which should be used with broadband sources. This addition also brings the possibility to analyze the results by group of sources.

EM noise workflow: support rotor skewing

Skewed rotors are now supported in the EM noise workflow. With this improvement, linear and V-shape skewing can be specified for the rotor in the new rotor skewing category in the Electromagnetic Model, with custom angles, and a different 2D result can be used for each angle.

EM Noise Workflow: support of axial motors with double air gap

The EM noise workflow was also modified to support axial motors, which have a different geometry than radial ones. The rotor is annular and sandwiched between two stators, and the electromagnetic flux is then along the rotation axis. To define such a motor, the Flux type, in the geometry category of the Electromagnetic model, should be set to axial instead of radial.

Damping Pad Positioning Workflow: advanced damping configuration reports

Two new improvements have been developed for the damping pad positioning workflow, in partnership with Autoneum. First, in the damping configuration tab, the selection of elements to define a damping area can be done automatically based on values of the computed mobility map. This allows to select easily elements where the mobility map is the highest, ensuring an efficient damping. Secondly, in the mobility map tab, an advanced damping configuration analysis report has been added. If several different dampings have been defined, this report will display which damping pads are the most efficient based either on a maximum allowed mass, or a relative efficiency threshold.

Nastran/Actran Space Workflow: possibility to re-use existing modes

A new option has been added to the WM_SPACE workflow, which connects Actran and Nastran for Diffuse Sound Field (DSF) applications. This option allows to skip the structure modal extraction step if the modes are already available. This decreases significantly the computational cost of running multiple configurations where the structural model is not changing. This option can be activated with the following syntax: `--modes_files_storage_directory=folder` where `folder` is the directory containing the already computed modes.

2.2.2 Aeroacoustics

Equivalent fan noise sources

This release of ACTRAN comes with a new ICFD utility (RING_DIPOLES) to compute equivalent fan noise sources from fan specifications, such as its diameter, RPM, power and number of blades. From those inputs, ACTRAN will compute the equivalent drag and thrust, and create a ring of properly phased dipoles. Those dipole sources can then be used in any acoustic simulation to represent the fan acoustic excitation.

Support of Double Degree Of Freedom (DDOF) liners and wire mesh as resistive layer

In previous releases, the acoustic liner material was limited to SDOF (Single Degree Of Freedom) with only perforated plate available as resistive layer. This release brings the possibility to specify a DDOF (Double Degree Of Freedom) acoustic liner, and specify a wire mesh as resistive layer. Those improvements allow for a more accurate representation of the liner impedance, integrating grazing flow effects and a higher flexibility, with parametrized liner geometry. To model a DDOF liner, an ACOUSTIC_LINER boundary condition can be created, which should point to two LINER_LAYER materials.

Ensignt Gold format support for ICFD idle mode

The ICFD idle mode can be used to launch simultaneously the CFD and ICFD computations. ICFD will process CFD results 'on the fly' as soon as they are available. This feature is now compatible with the EnsigntGold format. The CFD

solver should export the .case/.encas file at the beginning of the computation and update it at each timestep. As for the other CFD formats which were already compatible, this idle mode can be activated by specifying CHECK_CFD_FILES and CHECK_WAIT_TIME in the CAASOURCES ICFD datablock.

2.2.3 Solvers

Automatic usage of Block Low Rank factorization with high precision

A new automatic behavior of the Block Low-Rank (BLR) methodology is available for the MUMPS solver, which can be activated with the BLR AUTO parameter in the MUMPS solver property window. The solver will automatically switch between full and BLR high precision factorizations, based on the size of the model and the available memory. This will decrease computational time and memory consumption during factorization step, while still ensuring the results accuracy.

2.2.4 Graphical User Interface

Spectrogram plots in WaterfallViewer

A new spectrogram plot tool is available in WaterfallViewer. It allows to plot results along engine orders, resulting in a spectrogram diagram, with one line for each order. It allows to a better visualization and analysis of RPM-based and order-based results. The input data can be coming from one .plt file containing the complete run-up, or several .plt files (one by RPM/order). This tool can plot any given quantity (pressure, displacements, power, ...), and will automatically detect the orders for RPM-based results.

Post-processing data in project (.apf) files

Project (.apf) files saved with Actran 2023.1 can now contain post-processing data, such as maps or deform visualizations. It allows to safely store progress when doing post-processing in ACTRANVI and re-import easily custom post-processing displays.

New statusbar in the Graphical User Interface

An interactive statusbar has been added in all applications (ActranVI, PLTViewer, WaterfallViewer and WorkflowManager). It allows the user to see and change interactively the working directory, check the number of warnings of the last operation done and have a better understanding of the application state (busy or idle). In ActranVI, the active analysis and the location of the saved project .apf file are also part of this statusbar.

Merge of 'Real part' and 'Animate' operators

In previous releases, the Animate operator had to be manually selected in the display property window to perform a harmonic animation, instead of the default Real Part operator. Both operators have been merged for this release, introducing a new default operator, "Real Part (and Phase control/Animate)", which allows to perform harmonic animations more easily.

Keeping PID information in extruded meshes

Two new options have been added to the Extrude meshing tool. "Keep original PIDs distinction" allows to generate one extruded volume PID for each surface PID selected as input, and "Generate PIDs interface" will create a single surface PID which contains all the inner interfaces between the extruded volumes PIDs.

2.2.5 Various other improvements

- Improved user experience for the Extract Blade tool.
- Virtual SEA: Simplified setup for trimmed acoustic radiation, and EXTERIOR_PELLICULAR_ACOUSTIC is now compatible with EXTENDED_SOLUTION.
- Virtual SEA: Support subsystems which contain only 0D and 1D elements.
- WorkflowManager: Control curve styles in all plots, and allow graphical addition and removal of cuts.
- WorkflowManager: scripting now supports images and data export.
- WorkflowManager: WM_SPACE supports OP2 and OP4 Nastran super-elements.

2.2.6 Known issues resolved

- Energy Analysis: The output request code for injected power is changed from W_i to i_jP , to be aligned with all other analysis.
- Virtual SEA: Better robustness for industrial TL models
- Virtual SEA: Better robustness with LOCAL_DAMPING

Documentation and Support

Contents

3.1 Overview of the documentation	27
3.2 How to get support	29

3.1 Overview of the documentation

This User's Guide covers ACTRANVI, PLTVIEWER and WATERFALLVIEWER.

The modules ACTRAN/ACOUSTIC, ACTRAN/VIBROACOUSTIC, ACTRAN/AEROACOUSTIC, ACTRAN/TM, ACTRAN DGM and ACTRAN for NASTRAN are covered in dedicated User's Guide.

This User's Guide is organized in five parts:

Part I - Getting started with ACTRANVI - contains an overview of the ACTRAN features (Chapter 1), an introduction to this new revision (Chapter 2), the present overview of the documentation and tips for an efficient support (Chapter 3) and the guidelines for the installation (Chapter 4). This part also provides the different way to launch ACTRANVI (Chapter 5) and, finally, a guided example to quickly start with ACTRANVI (Chapter 6).

Part II - ACTRANVI Reference Guide - extensively describes all the functionalities of ACTRANVI to pre- and post-process an ACTRAN analysis. It contains five chapters:

- Chapter 8 describes all the menus and settings;
- Chapter 9 describes the graphical render window;

- Chapter 10 describes the different data trees and their content;
- Chapter 11 describes the usage of the toolbox;
- Chapter 12 describes the element selection tool.

Part III - PLTVIEWER Reference Guide - extensively describes all the functionalities of PLTVIEWER to post-process ACTRAN frequency response functions. It contains five chapters:

- Chapter 16 is the overview of the PLTVIEWER;
- Chapter 17 describes all the menus and settings;
- Chapter 18 describes the different data trees and their content;
- Chapter 19 describes the creation and edition of functions;
- Chapter 20 describes the graphical render window and the edition of figures.

Part IV - WATERFALLVIEWER Reference Guide - extensively describes all the functionalities of WATERFALLVIEWER to post-process ACTRAN waterfall diagrams. It contains five chapters:

- Chapter 22 is the overview of the WATERFALLVIEWER;
- Chapter 23 describes all the menus and settings;
- Chapter 24 describes the different data trees and their content;
- Chapter 25 describes the creation and edition of functions;
- Chapter 26 describes the graphical render window and the edition of figures.

Part V - Sessions and Scripting - details the use of sessions (Chapter 27) and the advanced capabilities of the API to easily create user scripts in ACTRANVI (Chapter 29) or PLTVIEWER and WATERFALLVIEWER (Chapter 30).

3.2 How to get support

Contents

3.1 Overview of the documentation	27
3.2 How to get support	29

3.2.1 Contact

For any technical question, please visit SimCompanion platform:

<https://simcompanion.hexagon.com/>.

Support Team may be contacted by creating a case from following webpage:

<https://simcompanion.hexagon.com/customers/s/case/Case/Default>

Alternatively, Support Team may be contacted by e-mail or phone:

For USA and North-America :

- e-mail : mi-msc-fft.support.na@hexagon.com
- phone :1-800-732-7284 and press 5

For France :

- e-mail : mi-msc-fft.support.fr@hexagon.com
- phone :+33-5-34-51-96-33

For all other countries : please contact your local distributor or support at:

- e-mail : mi-msc-fft.support@hexagon.com
- phone :+32-10-48-79-53

3.2.2 Submit a technical issue

To help us providing you an efficient support, please follow the guidelines below when submitting a technical issue:

- specify your name, company, department, e-mail address and phone number;

- specify the concerned product name and version;
- describe the issue by giving as many relevant details as possible:
 - a small picture can be very useful to understand the issue;
 - provide the full command line used to launch ACTRAN;
 - provide the error message displayed by ACTRAN;
 - ZIP and attach the input file and all related files (include files, output files, report directory, script used to launch ACTRAN, mesh files . . .); if the total files size is larger than 10Mb, please refer to the section below specifying how to send large files.
- explain which investigations have already been done to solve the issue;
- give the computer configuration (hardware type, number of CPUs, Operating System, available RAM, local scratch disk size. . .).

Your submitted issue will receive a Ticket ID (included in the subject field of the Support Team answer). When replying to the email, please do NOT modify the subject field as it contains important tracking information. If you want to submit another technical issue not related to a previous one, please do not use a previous subject including a Ticket ID already assigned and start from a blank e-mail. It will ease the treatment of your issue.

3.2.3 Start to solve an issue

Determine where the error message is coming from by looking the output messages such as the *.log file:

- is it an ACTRAN error message?
- is the error message generated by the operating system?

If an ACTRAN error message is related to a specific data block, try to reproduce the issue after removing this data block from the data file.

Send these preliminary conclusions to together with the other documents.

3.2.4 Exchange files

The Hexagon e-mail server blocks e-mails containing large attachment (larger than 10Mb) but there are several other ways of exchanging large files. Be confident that all files provided to Hexagon will be handled as confidential material. Please contact the support team to define the proper way to exchange larger files.

ACTRAN Installation

Contents

4.1 Supported platforms and 's Lifecycle	31
4.2 Online download of ACTRAN	32
4.3 Setting Up ACTRAN	32
4.4 Setting up the ACTRAN licensing server	33
4.5 Advanced - Parallel version	33
4.6 Installation Directory	33

4.1 Supported platforms and 's Lifecycle

is committed to providing the ACTRAN community with releases on the most suitable and popular platforms for numerical simulation. constantly monitors the market and evaluate the customers needs in order to remove old-fashion platforms from the supported list and add new ones that are the most relevant.

In this framework, ACTRAN has been compiled and tested on several platforms. The list of the supported platforms is available in the platform definition document, available at:

<https://hexagon.com/support-success/manufacturing-intelligence/design-engineering-support/platform-support>.

Please contact if your platform is not in the list.

4.1.1 's lifecycle

In order to rationalize the portfolio of platforms, a Product Lifecycle Management (PLM) has been set-up. A dedicated platform evolves in time from the BeginOfSales status to successively the EndOfSales, the EndOfLife and finally the

EndOfSupport status.

4.1.2 BeginOfSales

A platform supporting ACTRAN is at BeginOfSales when we provide an external release built on this platform.

4.1.3 EndOfSales

At any point in time, any supported platform can be decided to be at its EndOfSales. This may happen when a platform is unpopular or if the vendor of the platform marked the platform to be at its EndOfSales. From this point onward, we target to perform one last major release of ACTRAN on this platform. Afterwards, this platform reaches its EndOfLife.

4.1.4 EndOfLife

At that time, a last minor release of ACTRAN is performed. Bug-fixes on this platform may be provided until its EndOfSupport, depending on their origin.

4.1.5 EndOfSupport

At this point, no support at all will be provided anymore on this platform. The time between EndOfLife and EndOfSupport is maximally one year.

4.2 Online download of ACTRAN

ACTRAN can be downloaded from the <https://mscsoftware.flexnetoperations.com> website.

4.3 Setting Up ACTRAN

To properly install ACTRAN, please preferably refer to the complete instructions available on our server at <https://www.fft.be/Actran-installation>. Installation guidelines are provided in the following sections.

4.3.1 Windows platforms

Simply launch the graphical installer and follow the given instructions.

Windows Firewall may block some MPI features on all public and private networks. In case of a *Windows Security Alert* pop-up appears, please allow access to the needed processes to communicate on these networks.

4.3.2 Unix/Linux platforms

Execute the installer in a prompt and follow the given instructions.

4.4 Setting up the ACTRAN licensing server

The ACTRAN usage is controlled by FLEXnet. The set up of a minimal FLEXnet server is described here. It is however strongly advised to contact your organization's FLEXnet manager, who will be able to set up the server in compliance with your local rules related to licensing management.

The MSC licensing tool can be downloaded from the <https://mscsoftware.flexnetoperations.com> website.

To setup the ACTRAN licensing, execute the installer downloaded and follow the given instructions. Then, to correctly pursue the installation, please refer to the <https://www.fft.be/Licensing-installation> page.

To obtain a valid license file for this server, please contact the Support Team.

4.5 Advanced - Parallel version

Please refer to <https://hexagon.com/support-success/manufacturing-intelligence/design-engineering-support/platform-support> for more details about:

- the MPI libraries used within the parallel ACTRAN version;
- the supported interconnects.

The selected standard is *IntelMPI*. This version is entirely integrated within the ACTRAN productline.

4.6 Installation Directory

In the installation directory, besides the folders related to the different Actran releases, two other folders are available.

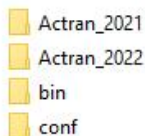

Figure 4.1: Bin and conf folders

The bin folder contains the script launched in background by Actran when executing the application. The script must not be modified in any case.

The conf folder contains two files the user can edit. The user can have a look to the `actran.in.template` which specifies the syntax to follow in the `actran.ini` file. This last one contains the default version that will be executed when launching the application. It can also contain the path to the license file which will be used in case the `MSC_LICENSE_FILE` environment variable can not be specified due to user rights.

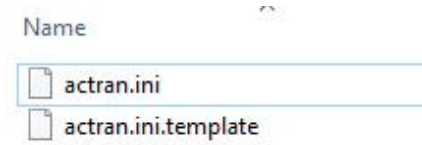

Figure 4.2: Conf folder

Launching ACTRANVI

Contents

5.1	Introduction	35
5.2	Screen resolution requirements	35
5.3	OpenGL requirements	35
5.4	Syntax of the command line	36
5.5	Launching the ACTRAN Launcher	37
5.6	Remarks and Further Reading	37

5.1 Introduction

The script to launch ACTRANVI is available in the installation folder under the name `actranvi`. On Windows platforms, a shortcut to this script is automatically created in the START menu.

5.2 Screen resolution requirements

ACTRANVI requires at least a full-HD (1920x1080) resolution. For high DPI screens (like 4K screens), it is possible for the user to scale the UI by defining `ACTRAN_HIGH_DPI_SCALING` as environment variable. This can improve readability.

5.3 OpenGL requirements

ACTRANVI requires to have a graphical card and matching drivers compatible with OpenGL-3.2.

5.4 Syntax of the command line

The execution of ACTRANVI can be started at the operating system prompt by typing a specific command line.

ACTRANVI command line options are provided by typing the following command:

```
actran -u VI --help
```

The usage of the command line for ACTRANVI is:

```
actran -u VI [options]
```

where the different options available are listed here below:

--autoparse, -e : is followed by the filename of the ACTRAN input file to be read;

--import_mesh, -i : is followed by the mesh file to be read;

--execute, -x : is followed by the script file to be executed;

--no_graphics, -n : deactivates the graphical support (post-processing is also disabled);

--export, -o : is followed by the filename of the output analysis read from --autoparse option;

--interfaces, -f : activates visualization of topological interfaces;

--report : is followed by the path of the report directory, where session and trace files will be written;

--debug : activate debug information and deactivate the redirection of the standard output to log frame;

--errorlevel : is followed by the severity level (INFO, EFFICIENCY, CAUTION, WARNING, FATAL) at which the application will abort;

--background, -b : leave the main window iconified;

`--run_dir` : is followed by a foldername within which all files or directories created by ACTRAN will be dumped. This option is currently only available for direct frequency response analyses.

The options [`--autoparse, -e`] and [`--import_mesh, -i`] and [`--execute, -x`] for the ACTRAN input file, the mesh file or the script file respectively are not mandatory when using the commandline `actranvi`. If the user do not specify one of the options, ACTRANVI will automatically detect if the file is an ACTRAN input file, a mesh file or a script file. The autodetection of filetype is supported for standard formats (.nff, .bdf, .op2 etc.). However, the autodetection is not supported for CFD formats. Consequently, it is mandatory to specify the options when working with CFD formats.

PLTVIEWER and WATERFALLVIEWER command line options are provided by typing the following command :

```
actran -u PLTViewer
```

```
actran -u WaterfallViewer
```

5.5 Launching the ACTRAN Launcher

The ACTRAN launcher (see Section 7.1.1 of Volume 1) can be used to launch an ACTRANVI session.

On Windows platforms, the ACTRAN launcher can be launched using the START menu:

```
START → MSC.Software → Actran Launcher [2023.1]
```

On Linux platforms, the ACTRAN launcher can be launched using the following command, after sourcing Actran (see next section):

```
actranw
```

5.6 Remarks and Further Reading

- On Windows platforms, the graphical applications can be launched in the START menu.

5.6.1 Sourcing script (backward compatibility)

In Actran versions prior to 2023 release, the sourcing of ACTRAN was required in batch mode. This requirement is not necessary anymore and ACTRAN can directly be used after installation without sourcing when using the "actran" command. For backward compatibility purposes, the sourcing shell script is still available in the installation directory under <actran-path>/productline/etc/ directory (setenv.bat for Windows platform, setenv.sh for Linux platform).

In order to secure the execution of ACTRAN in batch mode, a configuration shell script is available in the ACTRAN installation directory. The execution of this script has two major effects:

- it updates the PATH environment variable and adds the bin directory to the current PATH;
- it updates the LD_LIBRARY_PATH environment variable and adds the lib directory to the current LD_LIBRARY_PATH.

As those modifications are done in a shell script, they do not survive the session. As soon as the terminal is closed, the modifications are lost. Only one single version of ACTRAN can be used per session of terminal.

Use on Linux platforms

To call the shell script using BASH, please enter the following line (productline in lowercase) :

```
source <actran-path>/[productline]
```

For example, to use Actran_2023_1 that is installed in the directory /opt/FFT/, type :

```
source /opt/FFT/actran_2023_1
```

To call the shell script using SH, please enter the following line (be careful to write DOT SPACE before the productline):

```
. <actran-path>/[productline]
```

You will then be able to run the executables contained in the ACTRAN productline. To use multiple productlines, it is required to open a new session for each different productline. Undesired effects could occur if this general rule is not respected.

Use on Windows platforms

To call the shell script, simply call (productline in lowercase):

```
<actran-path>/[productline]
```

For example, to use Actran_2023_1 that is installed in the directory C:\FFT\, type :

```
C:\FFT\actran_2023_1.bat
```

You will then be able to call the executables contained in the productline. To use multiple productlines, it is needed to open a new command prompt for each different productline. Undesired effects could occur if this general rule is not respected.

A Guided Example - Horn Model

6.1 Introduction

A guided example is provided, through this Chapter, to illustrate the process of building an ACTRAN analysis, launching the analysis, and performing the post-processing.

The model that is considered represents a simple horn that radiates in half free field.

When following this guided example, the user should perform the same operations as indicated in the guide. In the current chapter, these operations are indicated in the following style (bullet and italic):

- *This is an action that the user needs to perform*
- *This is another action that the user needs to perform*

6.2 Overview of the Graphical User Interface

- *Start ACTRANVI. (Refer to Chapter 5)*

Figure 6.1 shows an overview of ACTRANVI's Graphical User Interface (GUI).

The GUI is composed of the followings parts:

- **Data tree** panel: containing mesh data, analysis data, and visualization;
- **render window**: for visualizing the finite element mesh;
- **Toolbox**;
- **Element selection** tool panel. By default, this panel is hidden when starting ACTRANVI

When ACTRANVI is started, the **Render window** is empty and the **data tree** panel contains only the basic data trees.

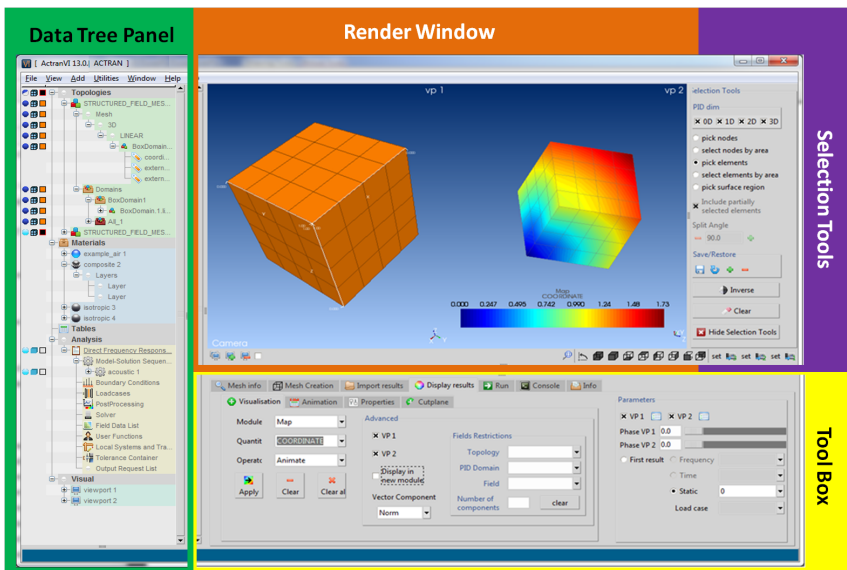

Figure 6.1: Overview of ACTRANVI's Graphical User Interface

6.3 Pre-processing

6.3.1 Import mesh

The following mesh data file is available in the folder of the ACTRANVI User's guide.

```
mesh_horn.dat
```

- *Load the mesh using the menu.*

File → Import mesh ... → DAT

- Click on "Display mesh".

When the mesh is imported, it is visualized in the **Render window**. The mesh information is shown under the **Topologies** tree.

A **topology** is composed of a **Mesh** tree and a **Domain** tree. In the **Mesh** tree, the imported finite element mesh is available. The different parts of the mesh appear in different groups according to their dimensions, element orders (linear or quadratic) and properties (identified by a property ID or **PID**).

- Left-click on the "+" and "-" signs in the **Topology tree** to develop or fold the trees, respectively (see **Figure 6.2**).

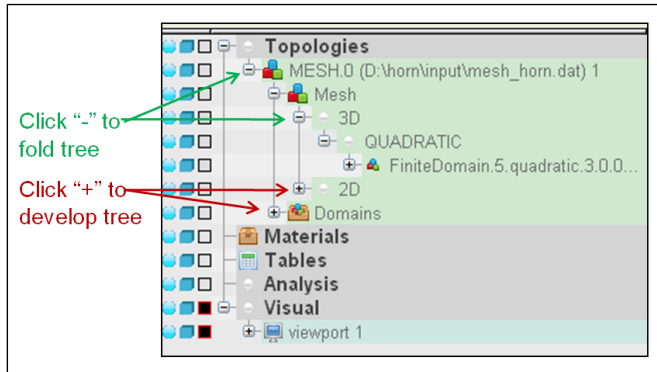

Figure 6.2: Develop and fold the trees

6.3.2 Render window operation and Mesh visibility

The set of icons on the bottom pane of the **Render window** may be used to change the angle of view (**Figure 6.3**).



Figure 6.3: Render window controls

In the **Render window**, the left mouse button is used to rotate the mesh. The middle button is used to translate the mesh (by holding the button and moving the mouse). The right button is used to zoom in or zoom out the mesh. The scroll wheel can also be used to zoom in or zoom out the mesh.

The **visibility** of the mesh parts can be changed using the three icons on the left side of the mesh parts items in the **Data tree panel**.

- *Adjust the mesh's size and position in the Render window;*
- *Adjust the visibility of the different trees in order to visualize the finite elements' wire. Set the 3D part semi-transparent, the 2D parts completely opaque, as shown in Figure 6.4*
- *Set different colors for the different mesh parts. Right-click on the topology's node (MESH.0), and choose "Set auto colors", as shown in Figure 6.5.*

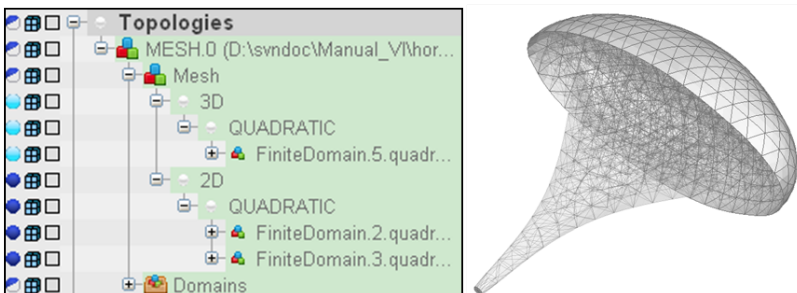

Figure 6.4: Adjust the visibility of the mesh

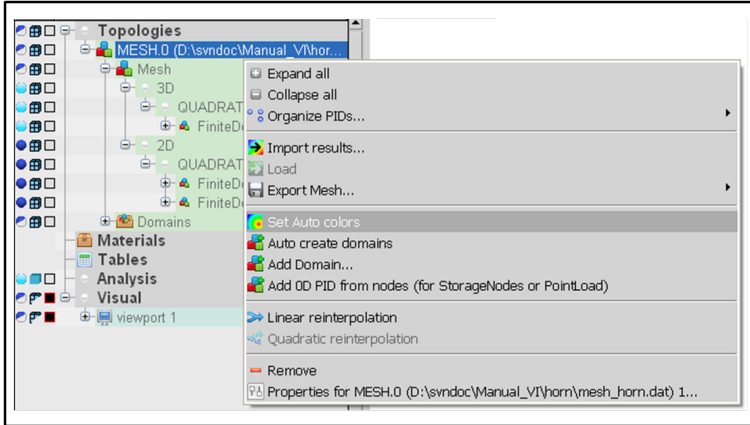

Figure 6.5: Set auto colors for different PID's

The resulting mesh visualization in the render window is shown in Figure 6.6.

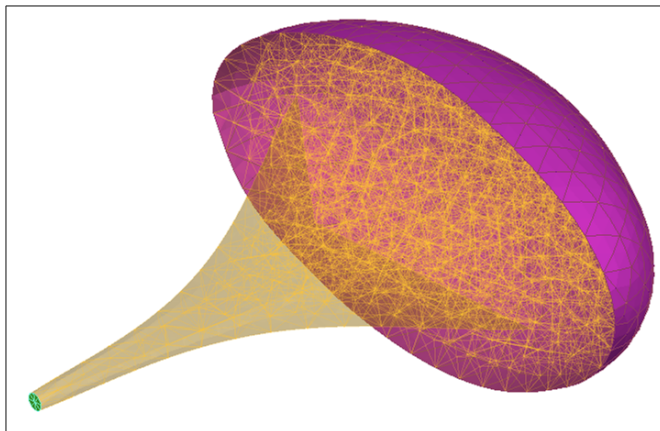

Figure 6.6: The mesh visualized in the render window

6.3.3 Identify the different parts in the input mesh

The mesh contains 3 parts: a 2D inlet surface; a 2D exterior surface and a 3D volume. (Figure 6.7).

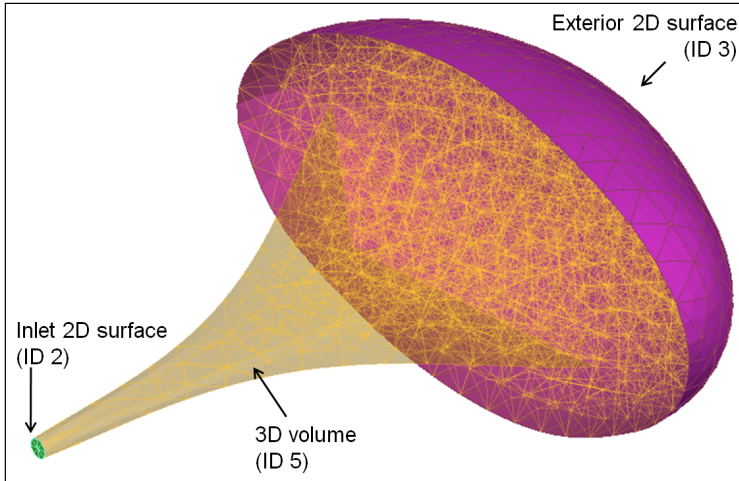

Figure 6.7: Different parts of the mesh

- *Identify the three parts of the mesh in ACTRANVI*

6.3.4 Create analysis

The horn model is solved in the frequency domain. For that, the user needs to create a Direct Frequency [Analysis](#).

- *Create a Direct Frequency Response using the main menu bar*

Add → Analysis → Direct Frequency Response

As the analysis is created, its [property window](#) pops up. In this window, the user can specify the desired frequency range of the analysis. This is shown in [Figure 6.8](#).

- *The objective is to define a frequency range from 10Hz to 2000Hz, with a step of 10Hz. For this purpose, Fill in the "Frequencies" field with value [10,10,2000] in the popup window;*
- *Close the window.*

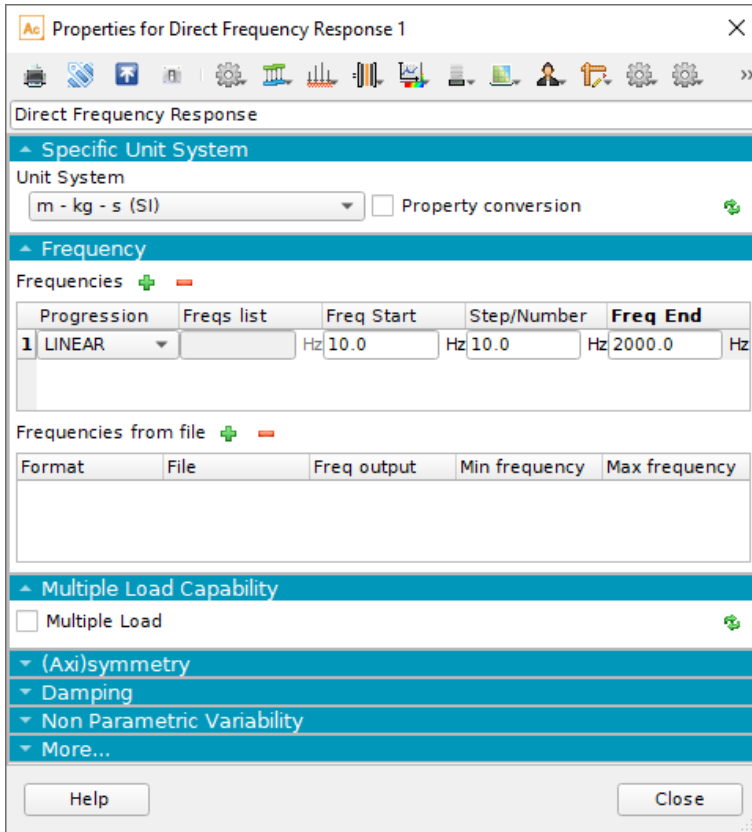

Figure 6.8: Specify the frequency range of the model

6.3.5 Create domains

In order to build an ACTRAN [Analysis](#), the user needs first to create the [Domains](#) in the [Topology](#) tree.

- *Create a Domain for the volume: right-click on the "Domains" and select "Add Domain..." (Figure 6.9);*
- *In the popup property window of the new domain, change the name of the Domain to "horn_volume" and select the volume mesh in the [scope selector](#) (Figure 6.10)*

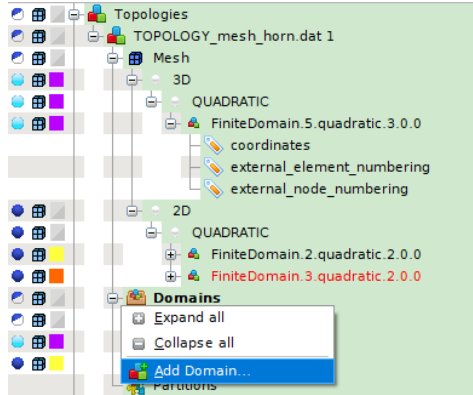

Figure 6.9: Add a new domain using the right-click menu of Domains

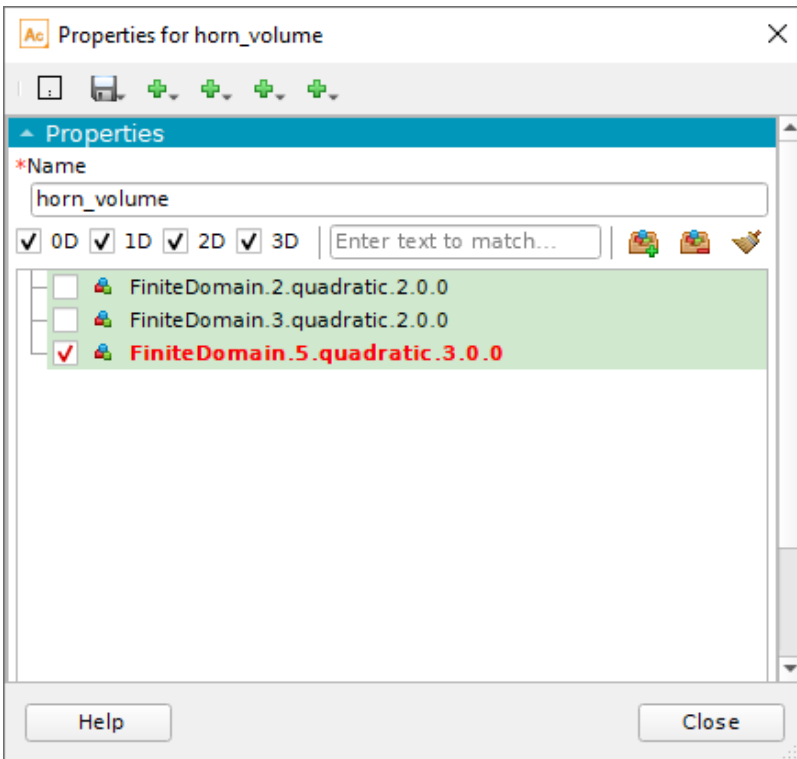

Figure 6.10: Select the volume mesh in the scope selector

- Create a Domain for the inlet surface. Domain name: *inlet_surface*;

- Create a Domain for the exterior surface. Domain name: *exterior_surface*.

The resulting Topology tree is shown in Figure 6.11.

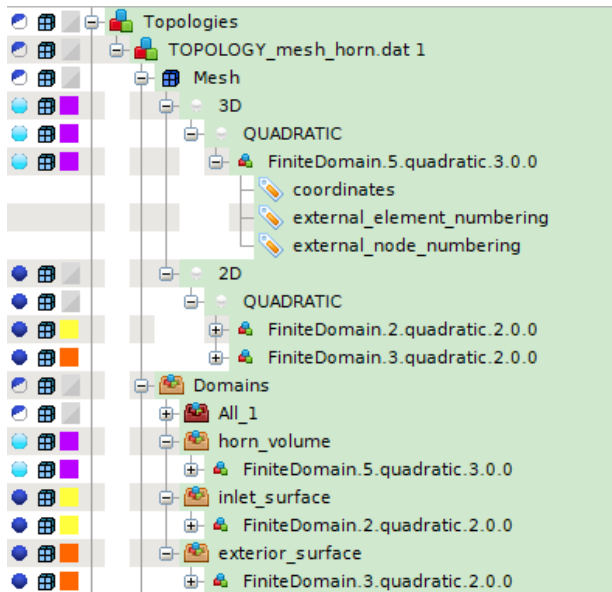

Figure 6.11: Topology tree after Domain creations

6.3.6 Create material

In order to model the acoustic propagation in the air medium, the user needs to create a fluid material. A material is created via the right-click menu of the Materials tree.

- Right-click on the "Materials" item and choose "Add Material..." in the contextual menu, then choose "Fluid Material" (Figure 6.12);
- In the popup property window of the fluid material, enter the material properties of air. The user can use the default value for each property, using the green icon (Figure 6.13).

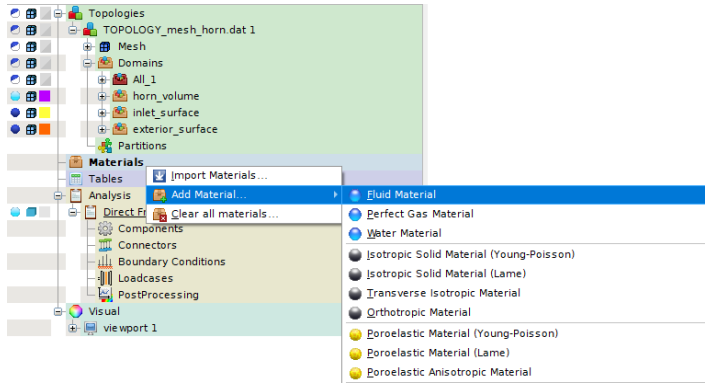

Figure 6.12: Add a new fluid material

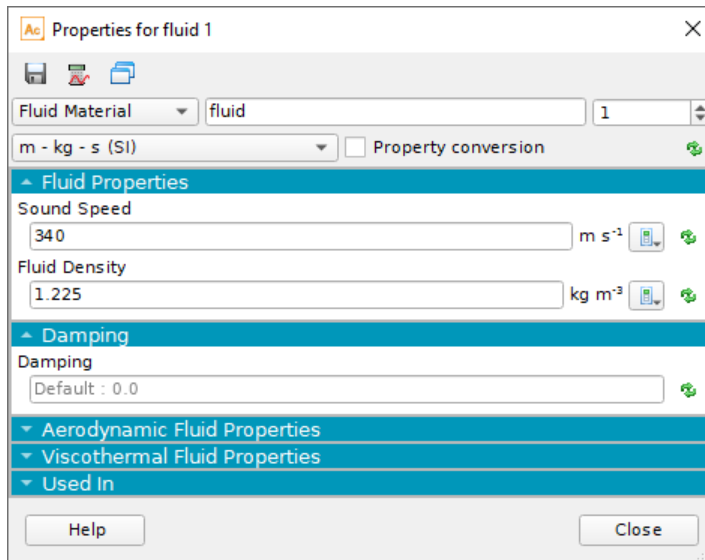

Figure 6.13: Edit the properties of the material

Remark: One can also import the air material from a material library. See [Import material](#) for more information.

6.3.7 Create a Finite Fluid component

In order to model the horn volume, the user needs to create a [Component](#). A component can be created in the Components node of the analysis.

- Right click on the "Components" item and choose "Add Component..." in the

contextual menu, then choose "Finite Fluid" (Figure 6.14);

- In the popup property window of the component, select the previously created fluid material and select the "horn_volume" domain in the scope selector (Figure 6.15).

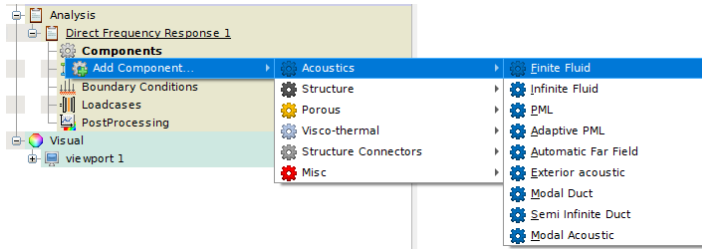

Figure 6.14: Create a Finite Fluid Component

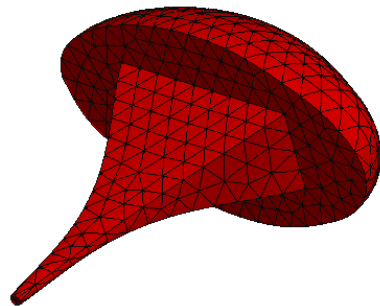
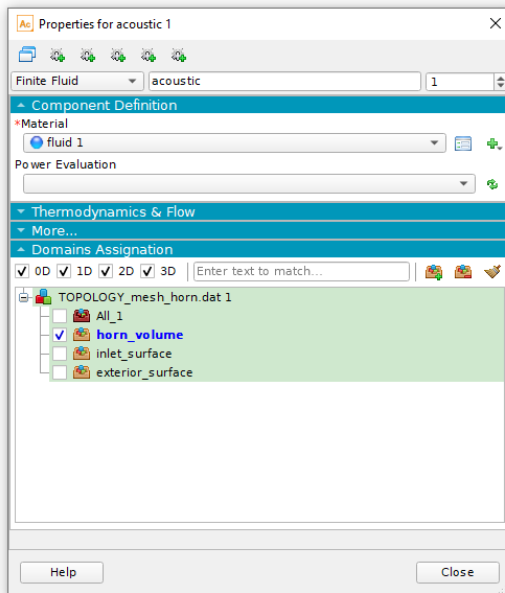

Figure 6.15: Edit the Finite Fluid Component

6.3.8 Create an Infinite Fluid component

In order to model the acoustic radiation in free field, the user needs to create an infinite fluid component. The infinite fluid component will be associated with the exterior surface mesh (the half ellipsoid).

- Right-click on the "Components" item and choose "Add new Component" in the contextual menu, then choose "Infinite Fluid";
- In the popup property window of the infinite fluid component:
 - Select the fluid material created previously
 - Edit the properties of the infinite component: specify an interpolation order "5"
 - Enter the center and the axes of the infinite domain ellipsoid,
 - Check the "Visible in viewports" box to visualize the ellipsoid,
 - Select the "exterior_surface" in the scope selector (Figure 6.16);
- Un-check the "Visible in viewports" box and close the window.

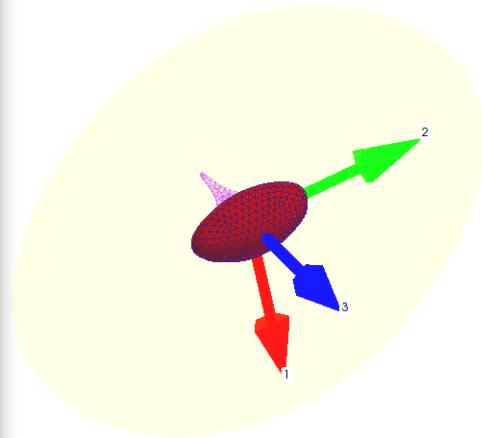
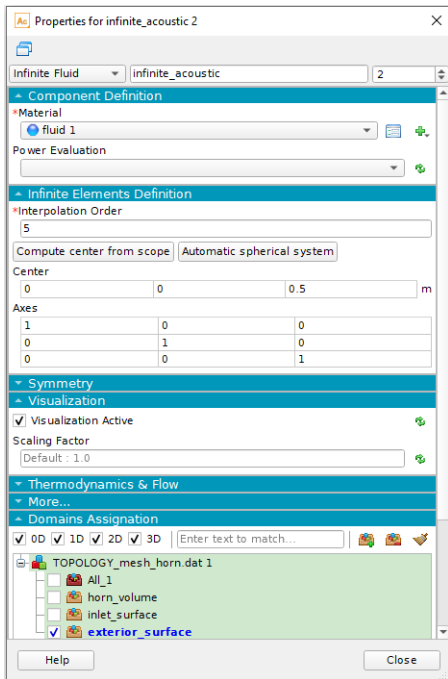

Figure 6.16: Edit the Infinite Fluid Component

6.3.9 Create the excitation

The horn inlet is excited by an acoustic acceleration. For this purpose, the user needs to create an acceleration boundary condition.

- Right-click on the "Boundary Conditions" item and choose "Add BC..." in the contextual menu, then choose "Acceleration";
- In the popup property window of the acceleration BC, enter the BC field value "1", and select the "inlet_surface" in the scope selector. (Figure 6.17).

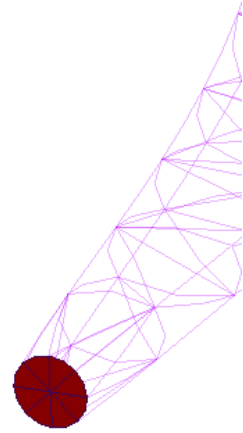
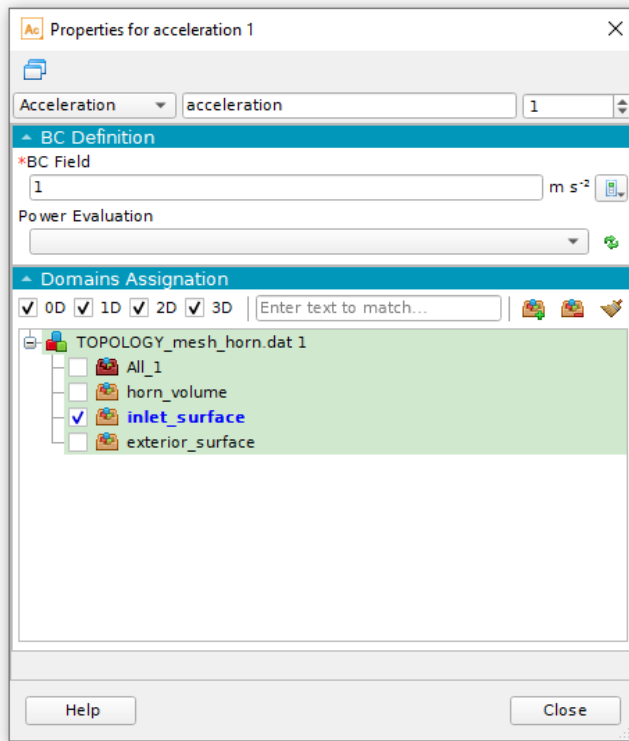

Figure 6.17: Edit the Acceleration Boundary Condition

6.3.10 Add the output requests

Three types of results can be produced by ACTRAN:

- Output FRF: output of Frequency Response Functions. This is the evolution of a specific result (acoustic pressure, acoustic intensity, etc.) with respect to the frequencies;
- Output Map: output of color map on the finite element mesh. This is a visualization of a result quantity everywhere in the computational domain for particular frequencies;

- Output Field Map: output of color map on a post-processing mesh that is different from the ACTRAN finite element mesh.
- *Right-click on the "PostProcessing" item of the analysis and choose "Add Output FRF" in the contextual menu. In the popup property window, enter the Output filename (the filename's extension is PLT):*

```
horn.plt
```

If one is interested in knowing the sound pressure level at specific locations, virtual microphones (called Field Points) should be defined in the [Toolbox](#) (below the [Render window](#)). In this example, the user will create two arcs of field points in far field (Figure 6.18), outside the finite element region, in order to plot directivity curves.

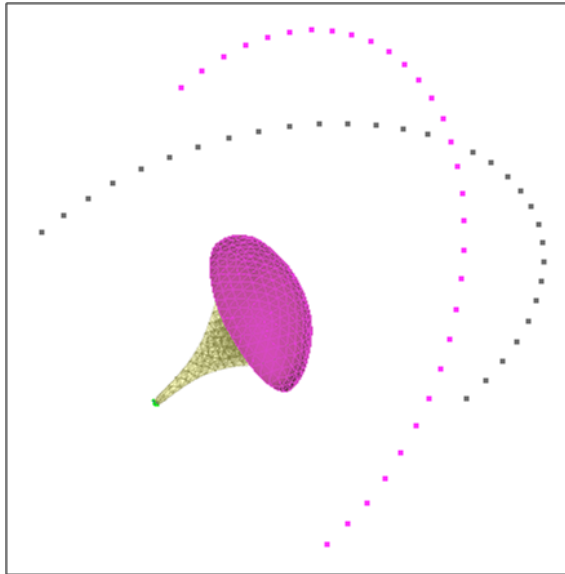

Figure 6.18: Two arcs of field points in the far field

- *In the [Toolbox](#), access to "Mesh" → "Meshing Tools" → "Points" → "Polar"; enter the parameters shown in Figure 6.19 and choose click "Create..." → "Field Points"*

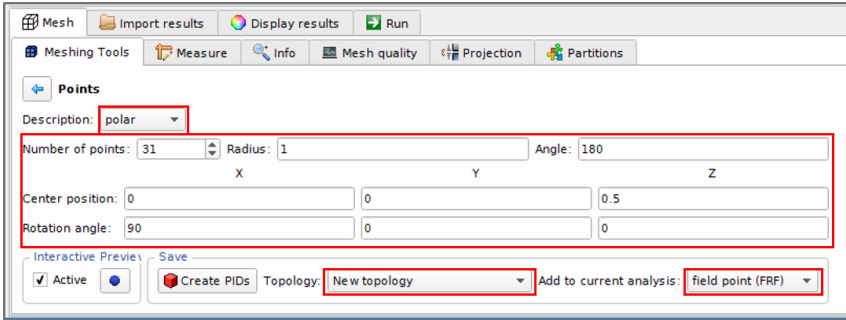

Figure 6.19: Create first series of field points

A new topology containing the field points is created. In this topology a **PID Domain** and a **Domain** are automatically created. The **Domain** is placed in the field point's scope under the Output FRF in the analysis (Figure 6.20)

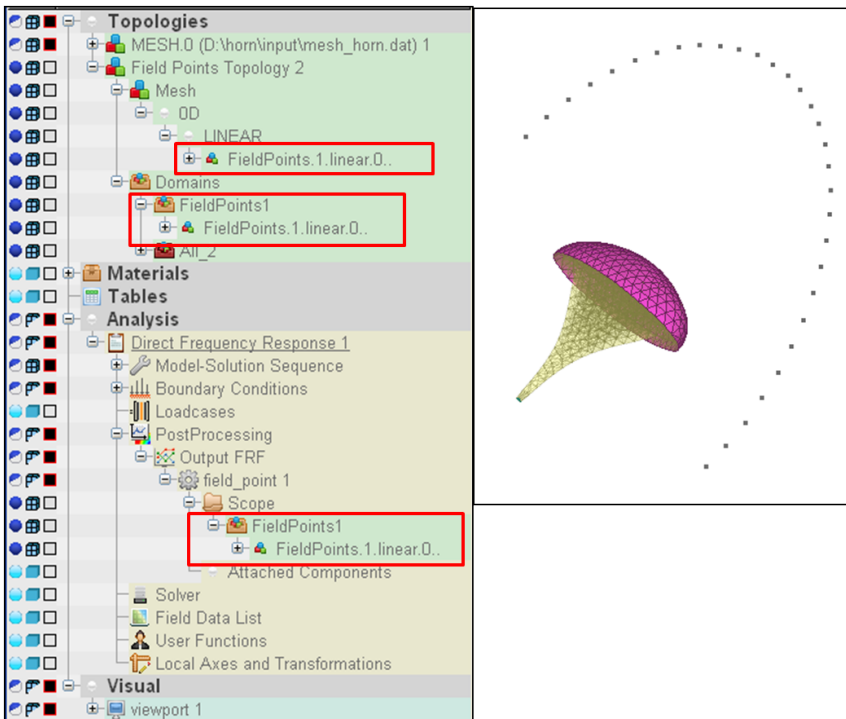

Figure 6.20: Field points created in Topology and associated with the Output FRF

A second set of field points needs to be created.

- In the *Toolbox*, access to "Mesh" → "Meshing Tools" → "Points" → "Polar"; enter the parameters shown in Figure 6.21;
- Select the field point topology created for the first series of field points; and click "Create..." → "Field Points".

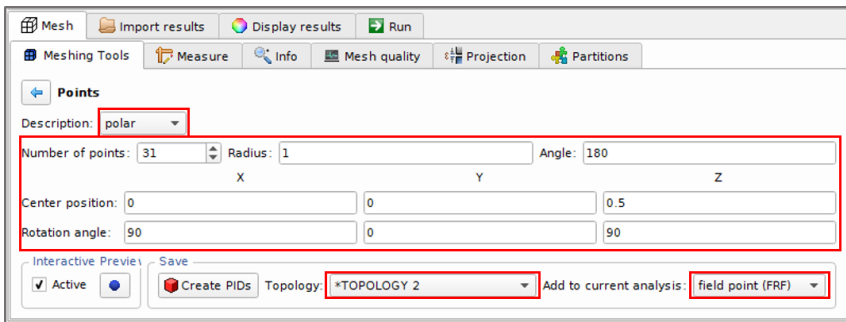

Figure 6.21: Create second series of field points

This second set of field points is created in the same topology as the first set. Under the Output FRF, a second field point is created.

Next, the user needs to create the Output Map request.

- Right-click on "PostProcessing" item and choose "Add Output Map" in the contextual menu (see Figure 6.22);
- In the popup property window, edit the parameters as shown in Figure 6.23)

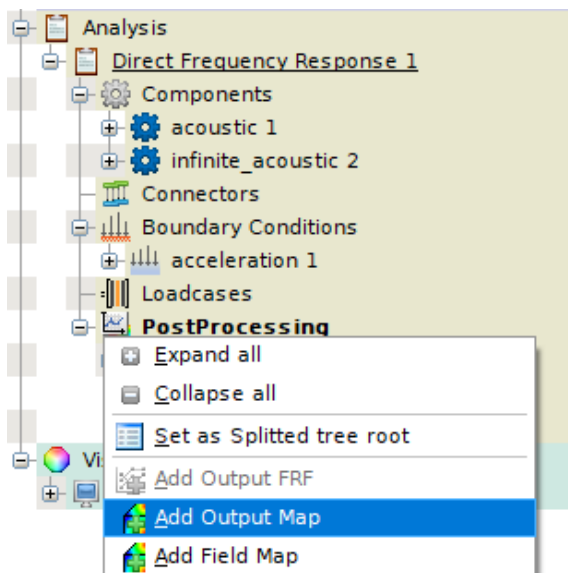

Figure 6.22: Create Output Map request

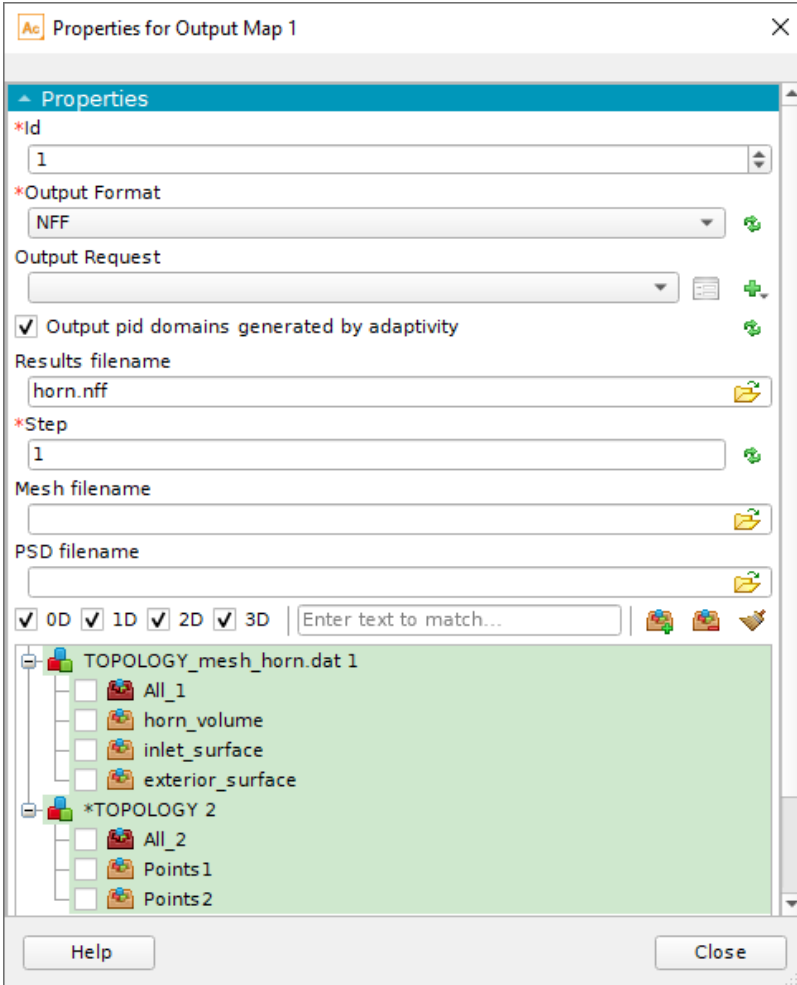

Figure 6.23: Edit the parameters of Output Map request

In order to produce color map on a post-processing mesh outside the finite element mesh, the user needs to add an Output Field Map under the PostProcessing node. For this purpose, a field mesh should be created (Figure 6.24).

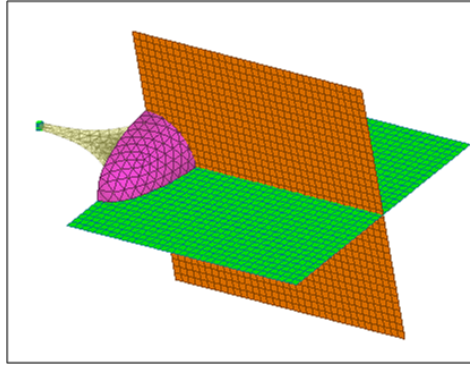

Figure 6.24: Mesh supporting the field map

- In the [Toolbox](#) → Mesh → Meshing Tools → Structured Mesh, create the first plane of field mesh (Figure 6.25);
- Create the second plane of field mesh (Figure 6.26)

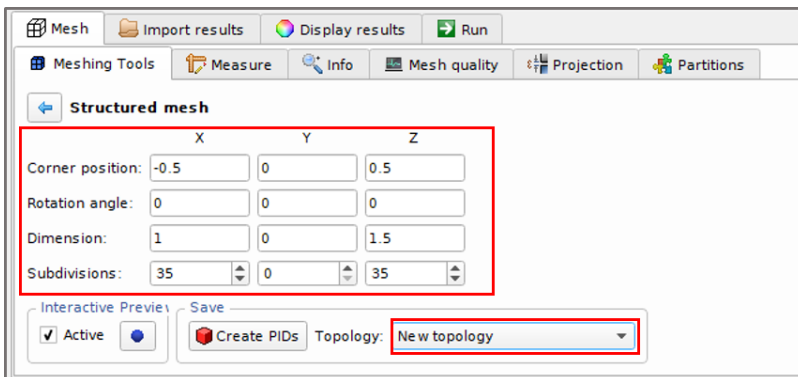

Figure 6.25: Create the first plane of field mesh

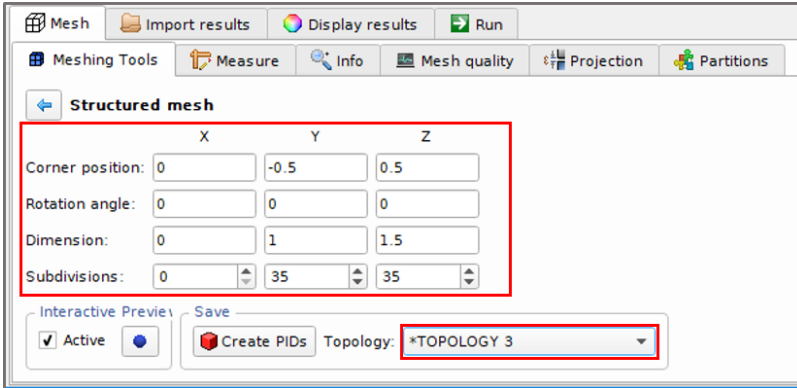

Figure 6.26: Create the second plane of field mesh

- Right-click on new topology item and choose "Auto create domains" in the contextual menu;
- Right-click on "PostProcessing" item and choose "Add Field Map" in the contextual menu;
- In the popup property window, edit the properties (Figure 6.27).

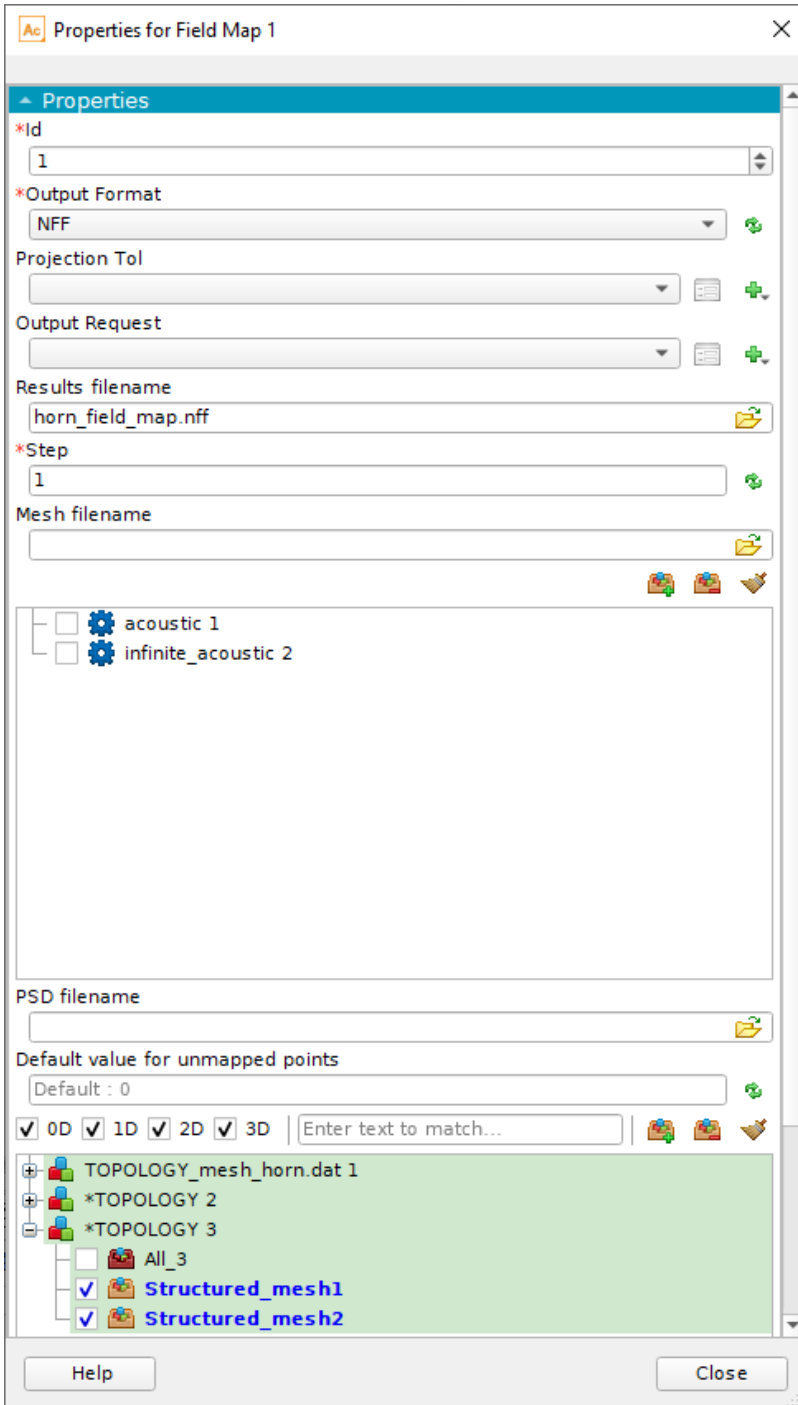

Figure 6.27: Edit the properties of the Field Map

6.3.11 Add solvers

Next, an algebraic solver needs to be selected. In this example, the Krylov solver is used. This Krylov solver will use the MUMPS solver as an internal sub-solver. For more information about the solvers, please refer to the ACTRAN User's Guide, Chapter 6 of Volume 1.

- Right-click on the Solver and add a Krylov solver (Figure 6.28);
- Right-click on the created Krylov solver and add a MUMPS sub-solver (Figure 6.29);

The resulting solver tree is shown in Figure 6.30.

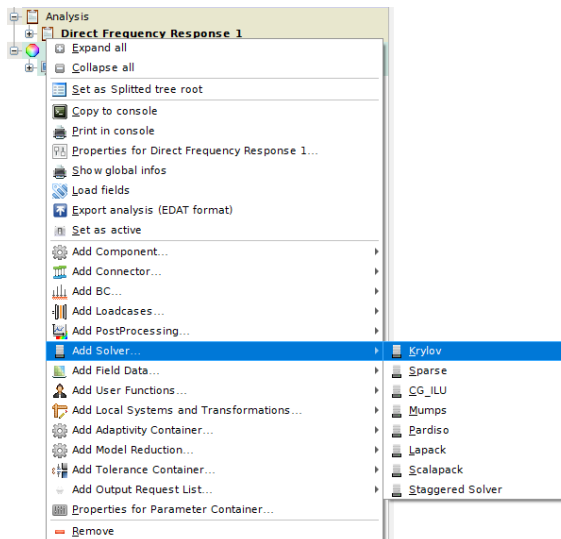

Figure 6.28: Select the Krylov solver

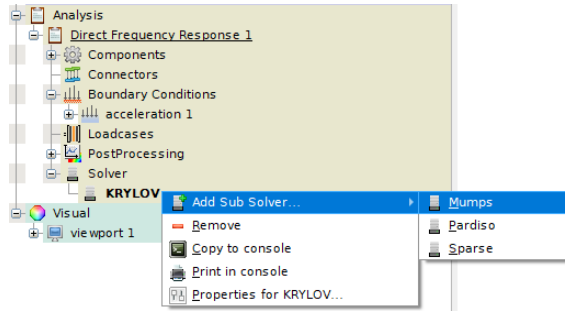

Figure 6.29: Select MUMPS as the sub-solver

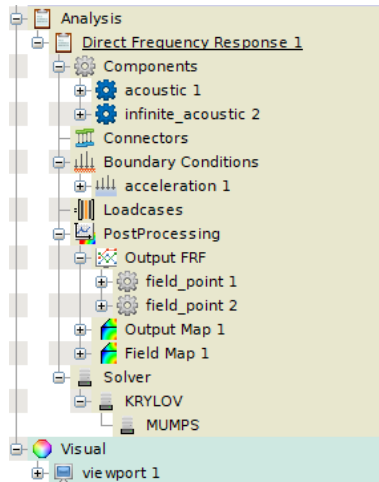

Figure 6.30: The resulting solver tree, with a Krylov solver and a MUMPS sub-solver

6.3.12 Export analysis

Once the complete model is built in ACTRANVI, the following step is to export the analysis into an ACTRAN input file.

- Right-click on the Direct Frequency Response, choose Export analysis (EDAT format), as shown in Figure 6.31;
- In the popup window, select the ACTRAN output format for the Topology, as shown in Figure 6.32;
- Name the exported analysis "horn.edat".

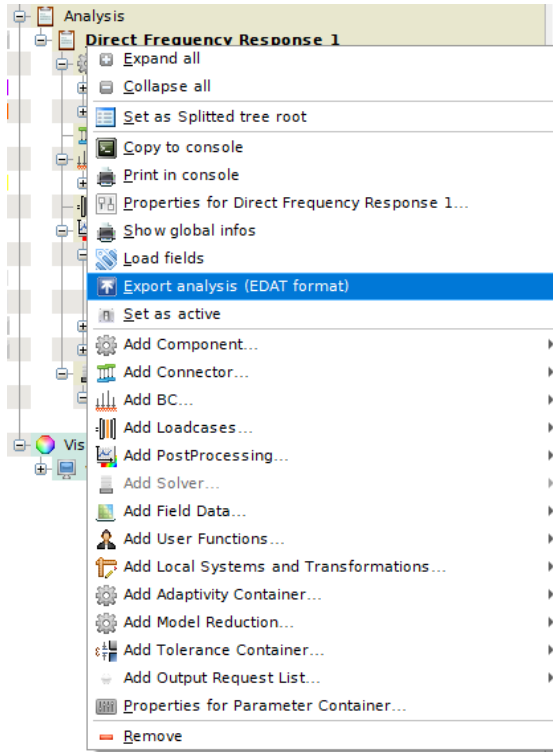

Figure 6.31: Export the analysis in EDAT format

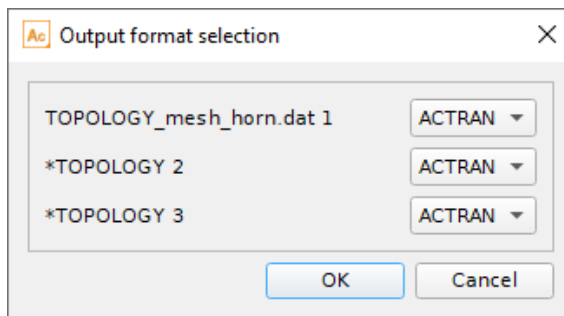

Figure 6.32: Choose ACTRAN format for the Topology export

6.4 Launch the computation

The computation can be started using the ACTRAN launcher (Figure 6.33). Refer to Chapter 5 on how to start the ACTRAN launcher.

- When starting the ACTRAN launcher, choose the model file "horn.edat" ;
- Edit the Command line options as it is shown in Figure 6.33 and click on the arrow to run the command.

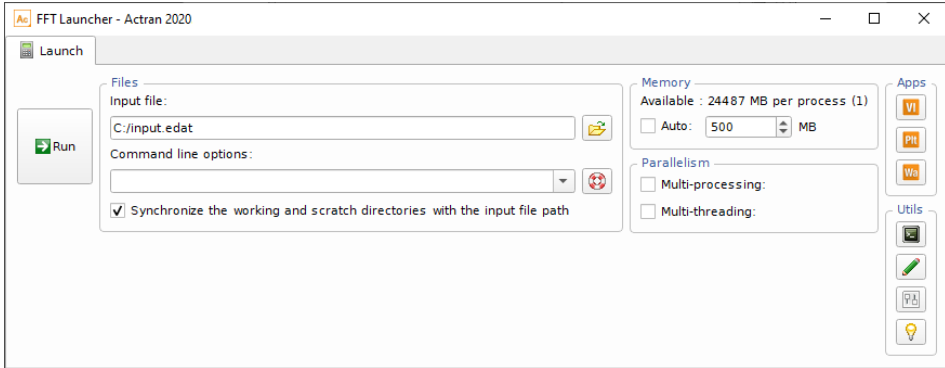

Figure 6.33: Launch the analysis model using the ACTRAN launcher

6.5 Post-processing

The computation produces three results files/folders:

- horn.plt: a text file containing frequency response functions of global and local indicators. For more information about the PLT file, please refer to the ACTRAN User's Guide, Section 12.5 of Volume 1;
- horn.nff: a folder containing the finite element mesh used in the computational domain and the color maps (NFF database);
- horn_field_map.nff: a folder containing the field mesh and the associated color maps.

6.5.1 Plotting the FRF's and directivity curves in PLTVIEWER

In this section, one will plot the frequency response functions (FRF's) and directivity curves using the PLTVIEWER. The PLTVIEWER is the dedicated utility to post-process and visualize the frequency response functions produced and stored in the PLT files by ACTRAN . Refer to Chapter 16 for more information on the PLTVIEWER.

- Start PLTVIEWER. Refer to Chapter 5

- Open the "horn.plt" result file in PLTVIEWER (Figure 6.34).

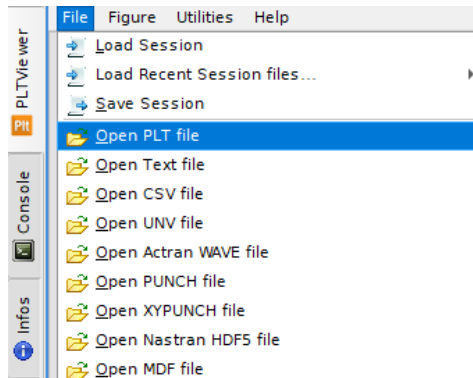

Figure 6.34: Import the PLT result file into PLTVIEWER

The imported PLT file is shown in the upper left window, as shown in Figure 6.35.

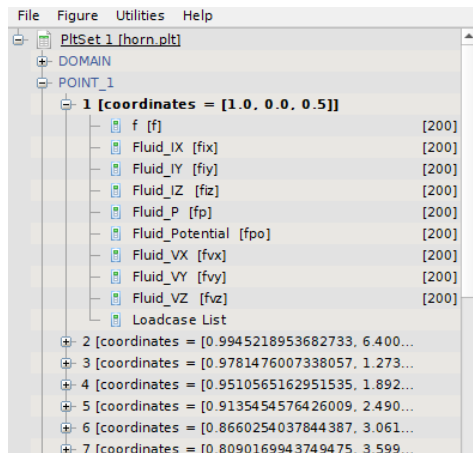

Figure 6.35: PLT results shown in the PLTVIEWER as data tree

Results calculated on the two arcs of field points are stored in "POINT_1" and "POINT_2".

- Plot the FRF of the acoustic pressure (dB) on point 10 in the first set of field points (Figure 6.36);

- Edit the properties of the curve in the Figure properties window and in the curve properties (Figure 6.37 and Figure 6.38).

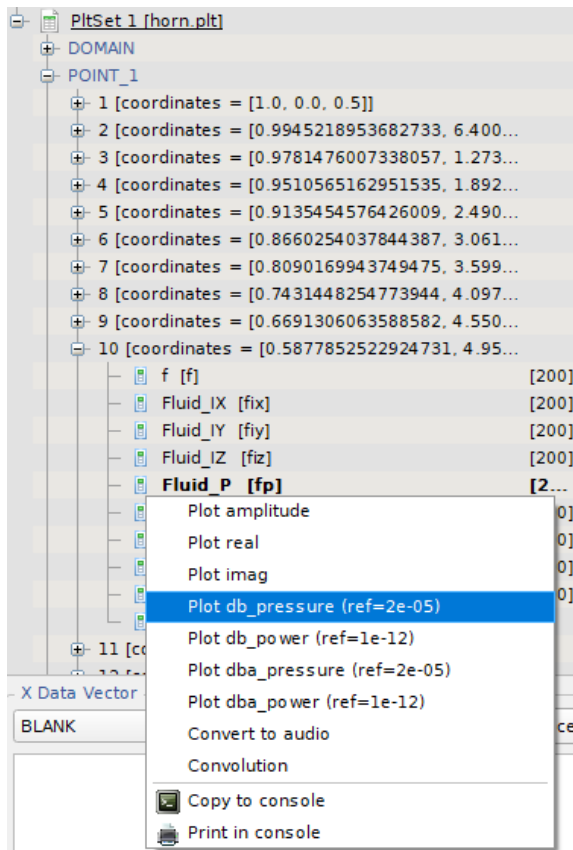

Figure 6.36: Plot the FRF of pressure in dB

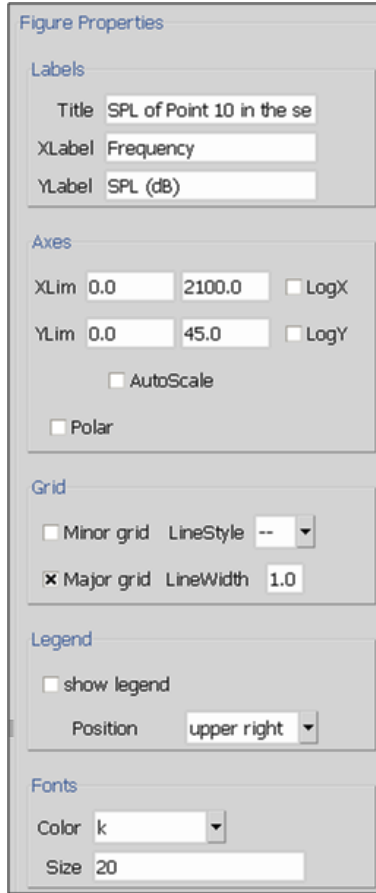

Figure 6.37: Edit the figure properties

	Pos.	Curve	Function	Line	Marker	Step	Opacity	Thickness	Label	Type	Interpolate	Tonal	Smoothing	Discard 0
1	1	✓	Curve 1	Function 1	solid	None	1	1.00	1.00	POINT_1 10	narrow_band	<input type="checkbox"/>	<input type="checkbox"/>	<input type="checkbox"/>

Figure 6.38: Edit the curve properties

The resulting curve is shown in Figure 6.39.

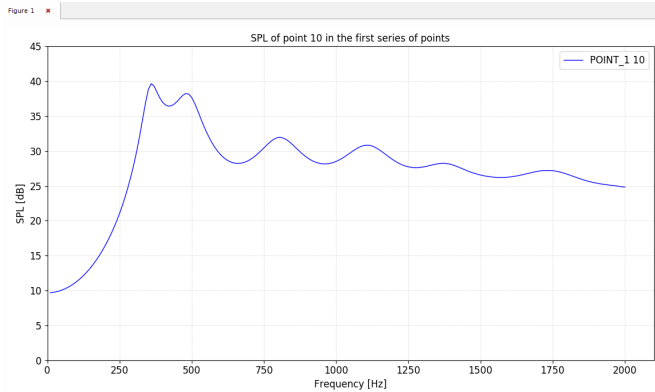

Figure 6.39: The FRF curve of pressure in dB

The next step aims at plotting the directivity curves of the pressure along different arcs of microphones at 2000Hz.

- Create a new figure window via the menu (Figure 6.40);
- Re-organize the PLT results in the data tree: Add a reverse set of the results (Figure 6.41).

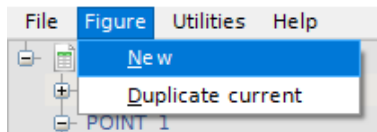

Figure 6.40: Create a new figure window

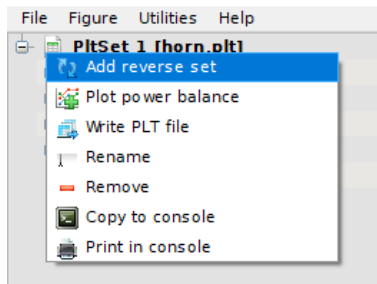

Figure 6.41: Add a reverse set of the PLT results

The reversed set of results is shown in Figure 6.42.

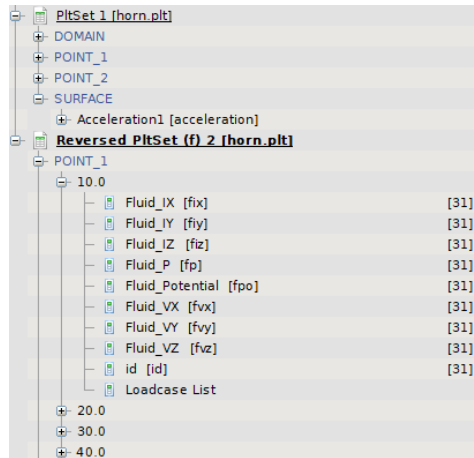

Figure 6.42: Reversed set of the PLT results

- In the reversed set, in the first series of field points, plot the pressure in dB for all the points at 2000Hz (Figure 6.43);
- In the second series of field points, plot the sound pressure level (SPL) in dB for all the points at 2000Hz. The resulting curves are shown in Figure 6.44.

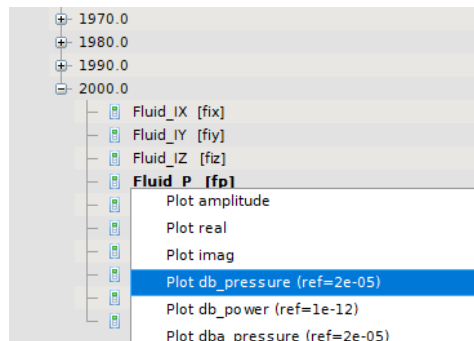

Figure 6.43: Plot the SPL directivity at 2000Hz

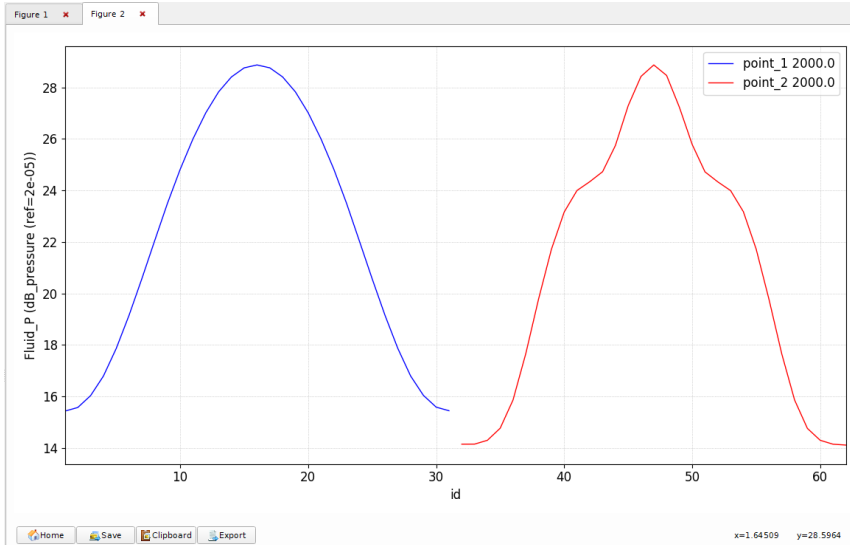

Figure 6.44: Directivity curves of pressure at 2000Hz

The directivity curves can be plotted in polar representation.

- *Select "Polar" in the figure properties window (Figure 6.45);*

- *Edit the functions of both directivity curves, in order to reflect the real angle of the series of the field points, as described in Figure 6.46. Click on Plot/Update after function edition.*

The resulting directivity curves are shown in Figure 6.47.

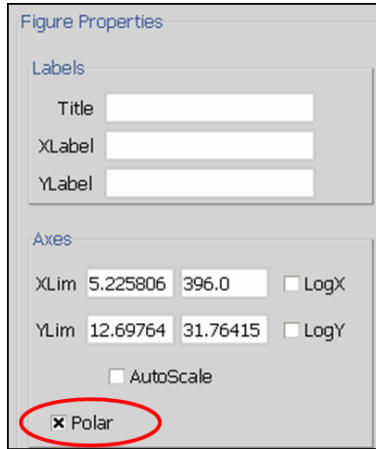

Figure 6.45: Polar representation for directivity curves

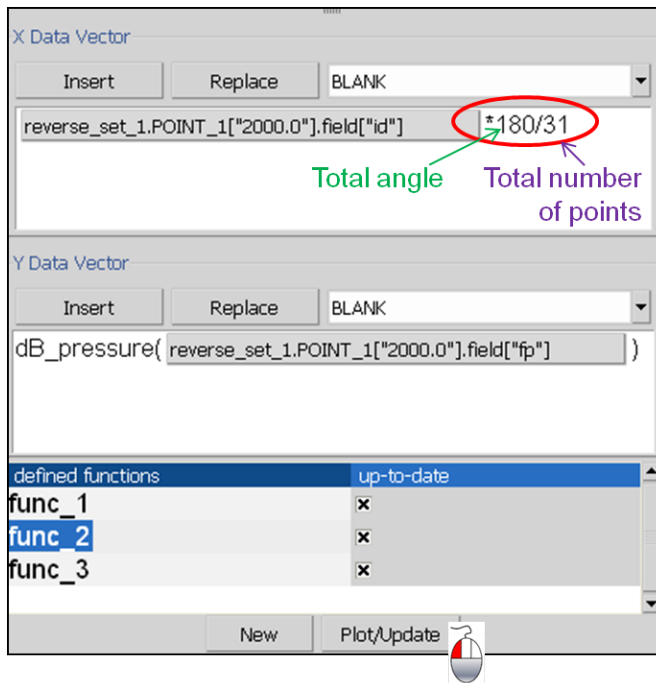

Figure 6.46: Edit the function of the directivity curves

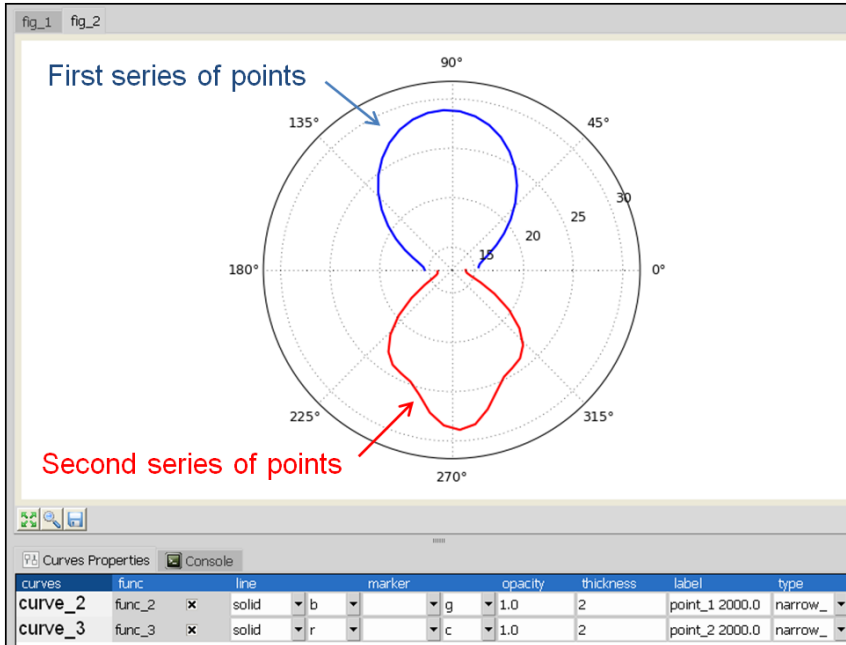

Figure 6.47: Directivity curves of pressure at 2000Hz shown in polar representation

6.5.2 Color maps on the horn model mesh

The results for plotting the color maps are stored in the NFF databases. In this example, the databases are named "horn.nff" and "horn_field_map.nff" (see Figure 6.23 and Figure 6.27). The "horn.nff" contains results on the acoustic computational domain. The "horn_field_map.nff" contains results on the post-processing mesh.

First, import the results from the "horn.nff".

- In ACTRANVI, import the "horn.nff" via the menu *File* → *Import mesh* → *NFF* and select "Display Mesh"

The mesh is imported as a Topology under the Topologies tree in the [Data tree panel](#).

- Turn off the visibility of all the topologies except the lastly imported "horn.nff" (Figure 6.48)

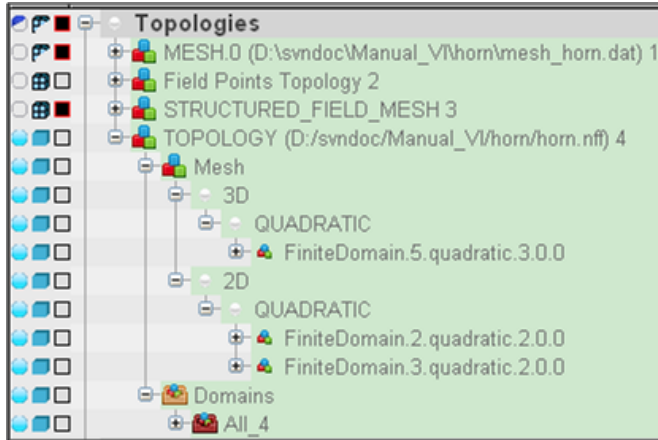

Figure 6.48: Import the horn.nff database and turn off the visibility of all other topologies

The next step is to import the results contained in the NFF database. This is done in the [Toolbox](#).

- In the [Toolbox](#), Import results tab, select the topology corresponding to the horn.nff and select the Pressure quantity to import, as shown in Figure 6.49;
- Left-click on the Import Selection.

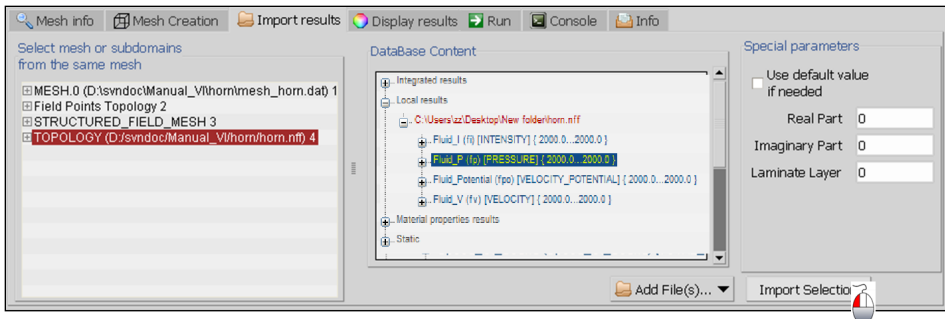

Figure 6.49: Import the pressure results from the horn.nff database

Next, plot the pressure map in the Display results tab in the [Toolbox](#).

- In the Display results tab, the quantity "PRESSURE" is automatically selected (as the last one imported) in the Quantity field (Figure 6.50);

- Left-click on *Apply*, the real part of the pressure is plotted in the *Render window* (Figure 6.51).

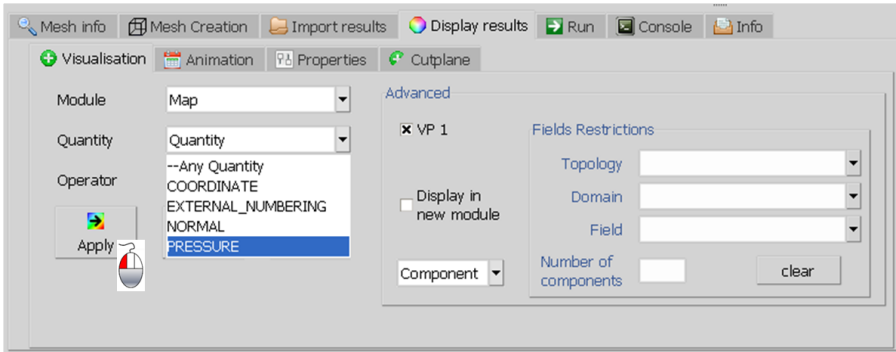

Figure 6.50: Plot the pressure results in color map

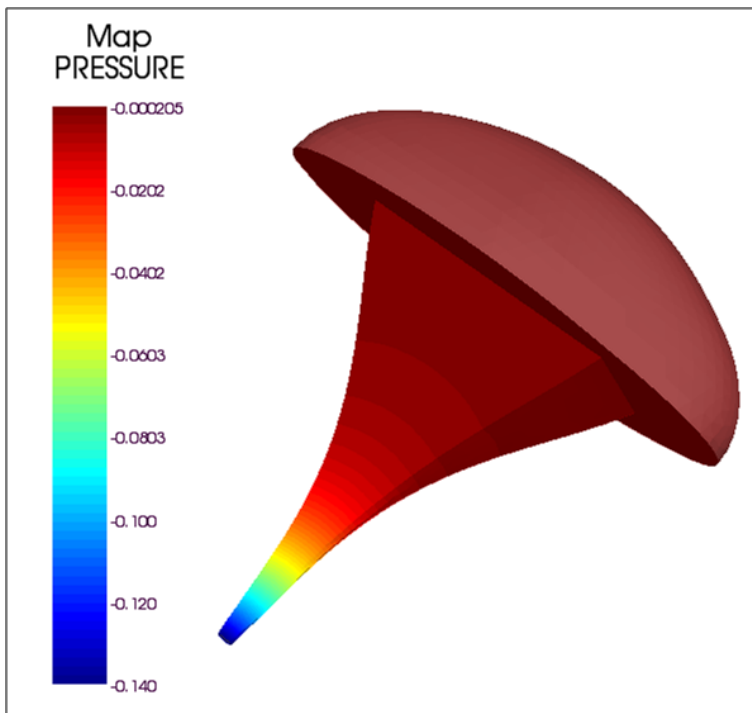

Figure 6.51: The pressure results plotted in the Render window

The result is displayed by default at the first available frequency. In order to

change the frequency, the user can adjust the parameters on the right side of the Toolbox (Figure 6.52).

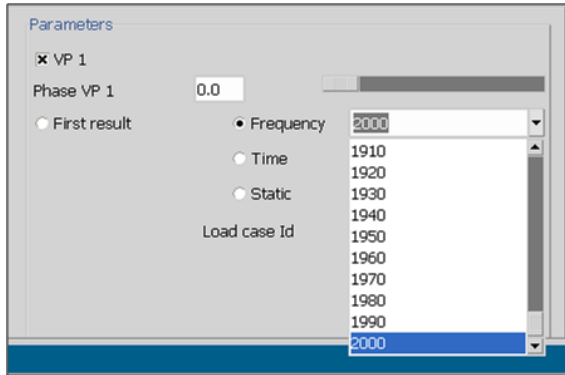

Figure 6.52: Change the frequency of the visualized result

The range for the visualized quantity can also be adjusted. This is done in the Properties tab. Figure 6.53 illustrates the steps to change the range of the pressure results.

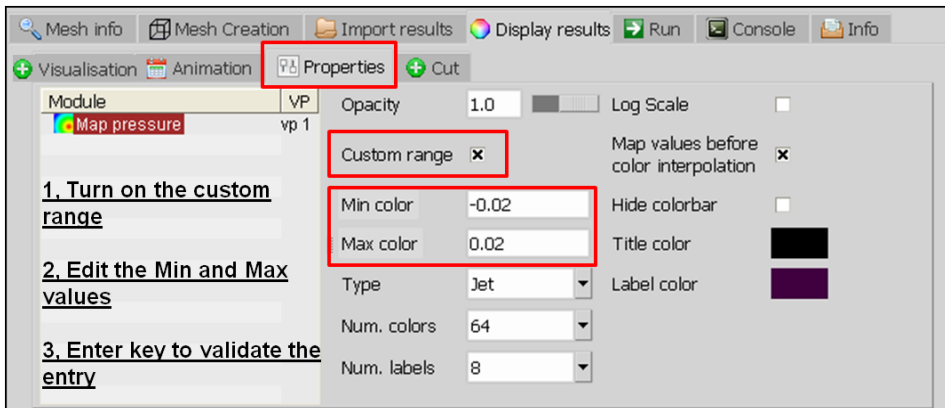

Figure 6.53: Change the range of the visualized result

Besides the visualization of the results on the model's exterior surface, one can also visualize the results in the interior of the domain, using the "Cut Planes".

- Add a cut-plane in the Cutplane tab (Figure 6.54).

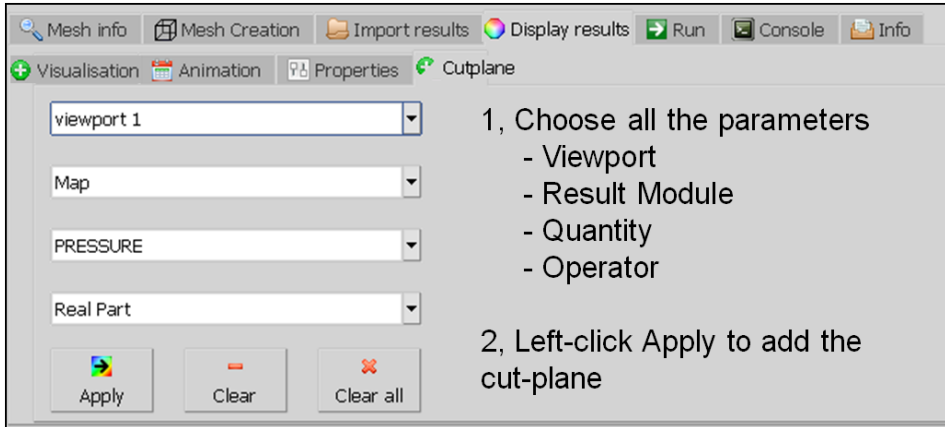

Figure 6.54: Create a cut-plane on the map result

As a cut-plane is added, the map visualized in the render window is on a flat 2D surface inside the computation domain. In the Properties tab, the cut-plane's position can be adjusted, together with its other properties.

- Change normal direction of the cut-plane from the X axis to the Y axis (Figure 6.55).

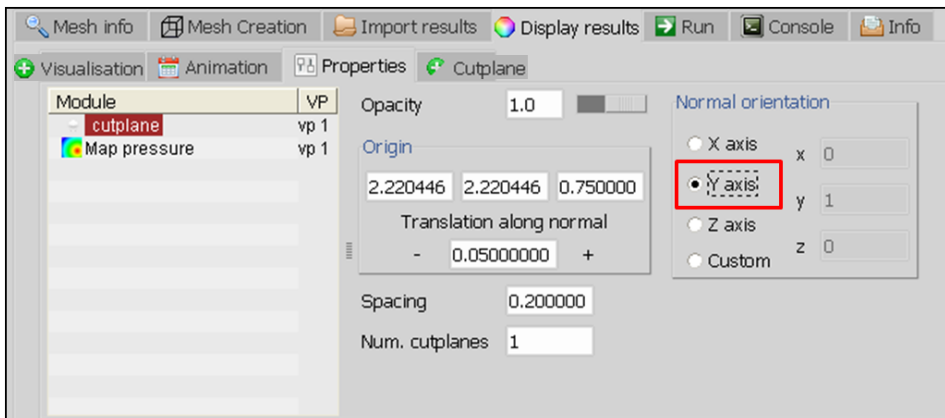

Figure 6.55: Change the properties of the cut-plane

The resulting map is shown in Figure 6.56.

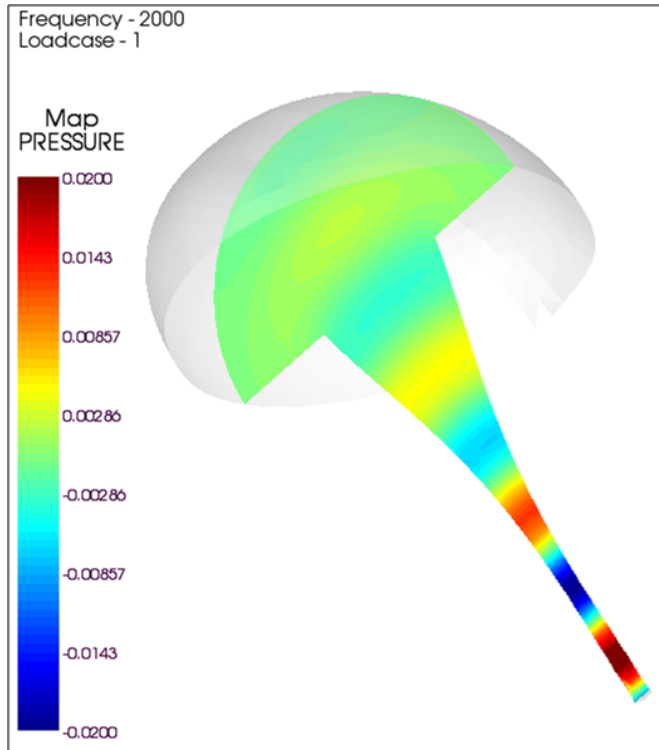

Figure 6.56: Result shown on a cut-plane

Several cut planes can be successively added to the visualization.

- *In Cutplane tab, add another cut-plane. Use the default properties for this second cut-plane*

The resulting map is shown in Figure [6.57](#).

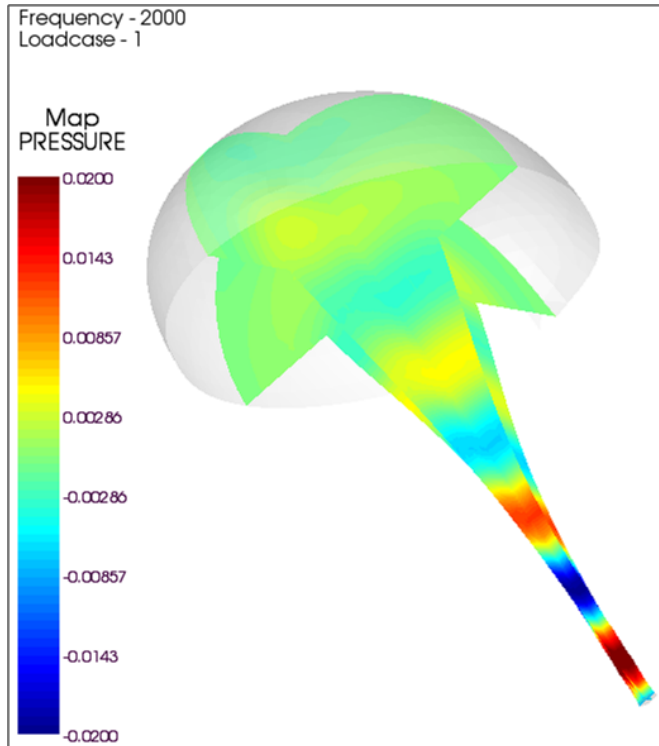

Figure 6.57: Result shown on two cut-planes

6.5.3 Color maps in far field

The results in far field (in the field map) are stored in the "horn_field_map.nff" database. The results can be imported and added to the current visualization.

- *Import the "horn_field_map.nff" via the menu File → Import mesh → NFF;*
- *In the [Toolbox](#) → Import results tab, import the pressure results on the field mesh (Figure 6.58).*

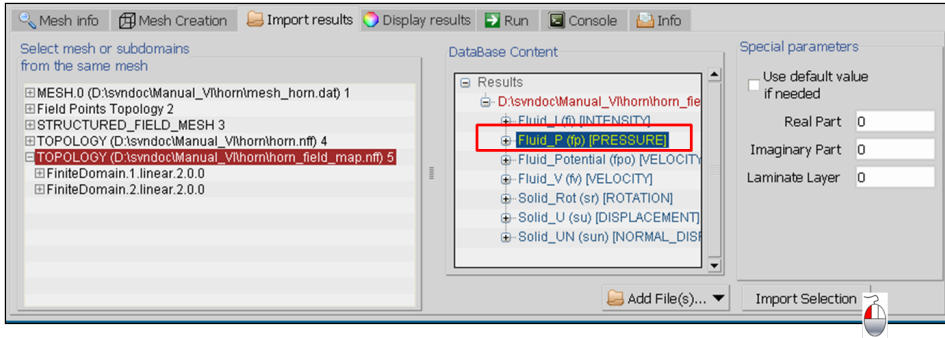

Figure 6.58: Import pressure results on the field mesh

When plotting the pressure result on the field mesh, the topology of the field mesh should be specified, as illustrated by Figure 6.59.

- *Plot the pressure results on the field mesh. (Figure 6.59)*

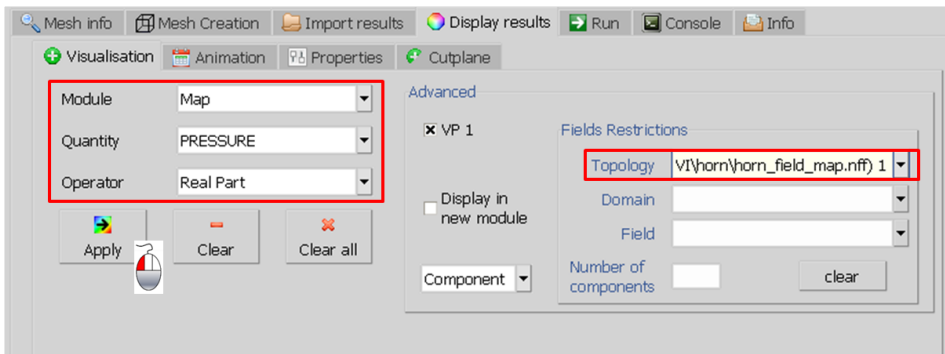

Figure 6.59: Plot the pressure results on the field mesh

Remark: If the user did not specify the topology of the field mesh, the pressure results will be plotted on all topologies where the pressure results have been imported.

The resulting map is shown in Figure 6.60.

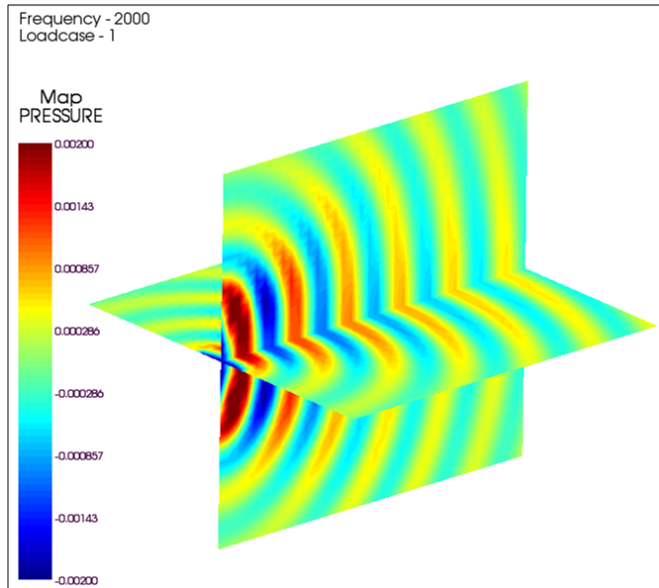

Figure 6.60: Pressure result on the field mesh

The results visualized in the [render window](#) can be saved in an image file:

Menu → File → Export Image

Part II

ACTRANVI Reference Guide

ACTRANVI Unified Interface

7.1 Introduction

The three pre-processing and post-processing tools available in ACTRAN (namely ACTRANVI, PLTVIEWER & WATERFALLVIEWER) can be accessed from a single graphical user interface ("GUI") window. This main window consists of two different parts : the applications notebook part and the info frame / console part. Figure 7.1 shows the unified graphical user interface.

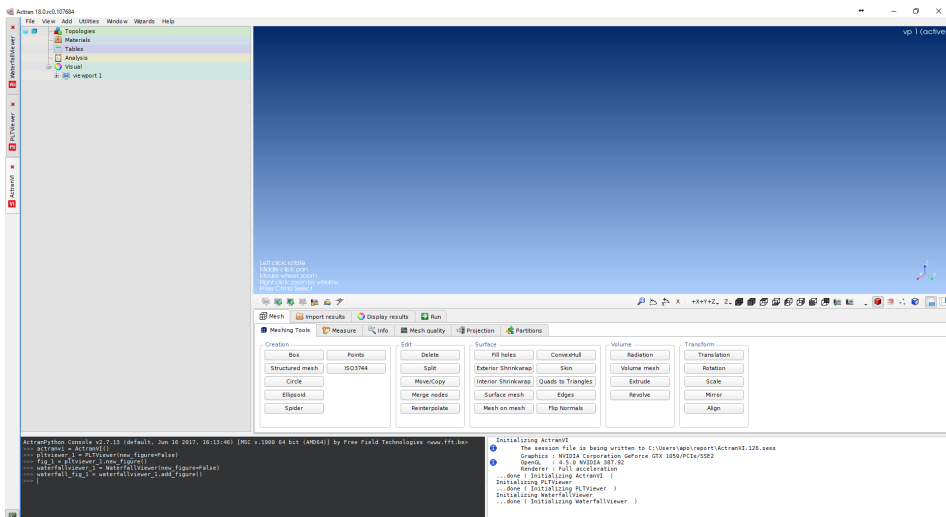

Figure 7.1: The unified user interface

The user is able to resize these two parts by left-clicking on the horizontal separation bar and moving the mouse to the new desired position.

7.2 The applications notebook panel

In the applications notebook part, each tool (namely, ACTRANVI, PLTVIEWER and WATERFALLVIEWER) can be opened in a separate tab, allowing the user to quickly switch from one tool to the other by left-clicking on the corresponding tab or by using the combination of <Ctrl+Tab> or <Ctrl+Shift+Tab> buttons to move between tabs in a downwards or upwards fashion respectively. Each tab is entitled with the name of the tool it contains. Only one instance of each tool can be opened in the main window, so there can be at most three tool tabs in this window, corresponding to ACTRANVI, PLTVIEWER and WATERFALLVIEWER simultaneously opened. The user can however open as many unified interface windows as he wants, exactly as the previous ACTRAN releases allowed to open any number of ACTRANVI, PLTVIEWER or WATERFALLVIEWER windows.

Most of the time, the user has two types of results he wants to post-process with the ACTRAN graphical user tools : FRF (frequency response function) results in the form of a plt (or txt) file (PLTVIEWER and/or WATERFALLVIEWER), and color map results in the form of any output format available in ACTRAN (NFF, OP2, ...) (ACTRANVI). For results analysis purposes, the user should want to compare these two types of results in an easy and convenient way. The user can detach each tab from the current window by left double-clicking on the tab. The detached window can then be put side-by-side with the original window. The tab can be re-inserted to the applications notebook panel by closing the detached tab using the X at the top-right corner.

7.3 The Console/InfoFrame panel

The second part of the main interface window is the info frame / console part. This part is common to all tabbed applications opened in the applications notebook part. It consists of the Console widget and the InfoFrame widget. The Console widget is where all the API commands (corresponding to the actions that are performed by the user in the graphical user interface) are dumped, and the InfoFrame is a container for all the user, warning, and error messages. All the API commands coming either from ACTRANVI, PLTVIEWER or WATERFALLVIEWER are dumped in this unified Console widget. In the same way, all the messages to the user, produced by any of the opened tool, are written in the unified InfoFrame widget. The user has the possibility to resize the Console/InfoFrame as he wants using the vertical separation bar between the two widgets. A keyboard shortcut is available to quickly hide/show the Console/InfoFrame panel : <Ctrl+t>. The Console and InfoFrame widgets can also be displayed in full-screen mode by clicking on the dedicated tabs that are located at the applications notebook panel.

ACTRANVI Menu

The main menu bar is located at the top of the ACTRANVI application. Different menus are available:

- File;
- View;
- Add;
- Tools;
- Utilities;
- Window;
- Wizards;
- Help.

Click [here](#) to see a video example.

8.1 "File" menu

Figure 8.1 shows the functions that can be accessed through the File menu.

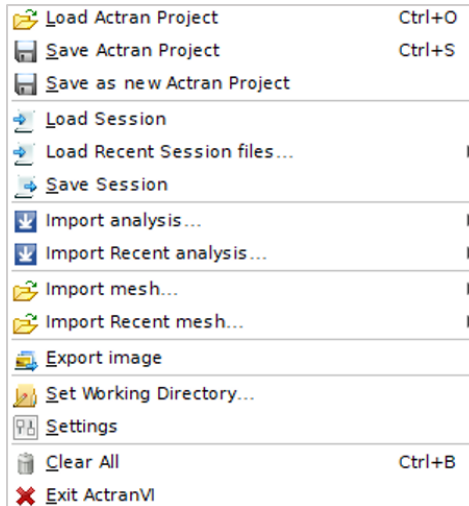

Figure 8.1: File menu in ACTRANVI

8.1.1 Load ACTRAN project

The "Load ACTRAN project" function imports an ACTRAN project into ACTRANVI. Only projects created with the same version of ACTRANVI can be loaded.

8.1.2 Save ACTRAN project

The "Save ACTRAN project" function exports the current ACTRAN project into an .apf file. This function is useful when the user wants to save their progress while the analysis is not yet complete.

8.1.3 Load session

The "Load Session" function imports and executes an ACTRANVI session. Two options are available:

- Automatic import file(s): all files referred in the session script are imported automatically (e.g. the import of a mesh file);
- Interactive import file(s): all files referred in the session script are not imported automatically. The application prompts the user to select the files. Therefore the user can select different files than those referred in the session script.

8.1.4 Save session

The "Save Session" function exports the operations recorded as API commands in an ASCII file (Chapter 29) since the current session of ACTRANVI has been started. The format of the exported session can be `.py` or `.sess`.

More information related to sessions and to the API language of ACTRANVI can be found in the section [Console](#) and in Chapters 27 and 29.

8.1.5 Import analysis

The "Import analysis" function is subdivided into four tabs:

- "ACTRAN analysis" imports an ACTRAN [analysis](#) and/or an ACTRAN [utility analysis](#) (ICFD, etc.).

Remark. *The [Flow mesh model](#) cannot be imported through this function, see section below.*

- The "NASTRAN analysis" function imports a NASTRAN analysis. For more information, please refer to Section 58.12 of Volume 1.
- The "NASTRAN OP2 PEM analysis" function imports a NASTRAN OP2 file generated during the initialization of a PEM computation through NASTRAN (NASTRAN 2013 or any release following this version is required). Please refer to the NASTRAN Quick Reference guide for further details about the PEM definition or contact the Hexagon Support.
- The "Flow Mesh analysis" function imports a [Flow mesh model](#).

8.1.6 Import mesh

A large number of input mesh formats are supported by ACTRANVI. When a mesh file is imported, a [Topology](#) is created.

It is also possible to import a CAD file directly in ActranVI. The supported formats are:

- **CATIA_V5:** *.CATPart, *.CATProduct
- *.igs
- **Inventor:** *.ipt
- **SolidWorks:** *.SLDPRT
- *.step

- **Parasolid:** *.x_t

When importing a CAD file, the user has the possibility to define the maximum length of the elements and the maximum deviation in order to get the desired mesh. Also, a CAD item will be created in the **Topology** datatree. From this datatree, the user will be able to visualize the CAD structure organized in assembly, sub-assemblies and entities. By right clicking on the assembly, it is possible to remesh or stitch the entire CAD. In addition, new flexibility is added by having the possibility to select multiple sub-assemblies or multiple entities to be remeshed or stitched, without having to work on the entire CAD.

8.1.7 Import Recent Session files/analysis/mesh...

ACTRANVI keeps an history of the recent open/saved files. One can respectively access a specific recent session, analysis or mesh straightly through the related "Import Recent..." function.

8.1.8 Export image

The Export image function generates a screen shot of the **render window** and save it as an image file. The supported image formats are: BMP, JPEG, PNG and EPS.

8.1.9 Set working directory

This function sets the working directory for ACTRANVI. When clicked, a pop-up appears (Figure 8.2).

Click [here](#) to see a video example.

The specification of the working directory is important when importing and/or exporting an analysis file where references to other files are included.



Figure 8.2: Set working directory

When the user imports an analysis, the working directory is updated to the directory containing the ACTRAN input file. For analyses containing INCLUDE_FILEINCLUDE_FILE keywords (refer to ACTRAN User's Guide Section 2.10 of Volume 2), ACTRANVI locates the included files using the combination of the working directory and their relative paths. This localization operation can be automatically performed.

8.1.10 Settings

In the Settings configuration panel, the user can configure the settings of ACTRANVI. More information on settings can be found in Section 8.9.

8.1.11 Clear All

The "Clear All" function deletes all the following items in an ACTRANVI application:

- Topologies;
- Materials;
- Tables;
- Analyses;
- Viewports;
- Results and results visualizations.

The session of the current ACTRANVI application is not cleared. Operations after the "Clear All" in the same ACTRANVI application are recorded in the same session file.

8.1.12 Exit ACTRANVI

Exit ACTRANVI.

8.2 "View" menu

Figure 8.3 shows the functions that can be accessed through the View menu.



Figure 8.3: View menu in ACTRANVI

8.2.1 Viewport

The following operations related to [viewports](#) can be accessed:

- **Add Viewport (new):** Add a new empty viewport;
- **Add Viewport (clone):** Add a new viewport and copy the content of other viewports into this new viewport (the visualisation is not copied, only the topologies);
- **Remove Viewport:** Select a viewport to remove;
- **Sync/unsync cameras:** Switch between synchronized and unsynchronized cameras of different viewports.

8.3 "Add" menu

Figure 8.4 shows the functions that can be accessed through the Add menu.

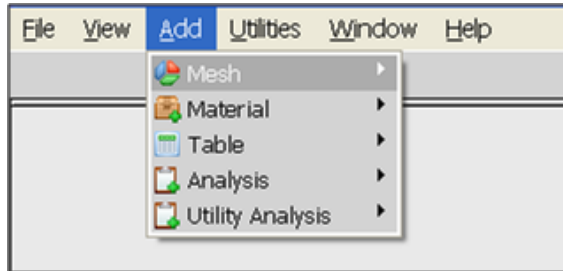

Figure 8.4: Add menu in ACTRANVI

8.3.1 Mesh

The "Add > BOXPRO topology" function creates a new [Topology](#) using the BOXPRO formalism. This is powerful for box-like problems (Section [10.3.12](#)).

The other functions in this sub-menu are direct links to the [Mesh creation](#) tab of the [Toolbox](#) panel (Section [11.1](#)).

8.3.2 Material

The "Add > Material" function creates a Material. Refer to ACTRAN User's Guide Section [7.1](#) of Volume 2.

8.3.3 Table

The "Add > Table" function creates a Table. Refer to ACTRAN User's Guide Section [11.30](#) of Volume 2.

8.3.4 Analysis

The "Add > Analysis" function creates an ACTRAN [Analysis](#).

8.3.5 Utilities analysis

The "Add > Utilities" analysis function creates an ACTRAN [Utility analysis](#).

8.4 "Tools" menu

Figure 8.5 shows the functions that can be accessed through the Tools menu.

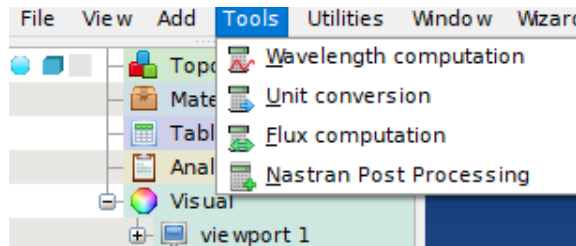

Figure 8.5: Tools menu in ACTRANVI

8.4.1 Wavelength Computation tool

This computational tool allows to compute the acoustic, bending or structural analytical wavelengths for fluids, solids and porous materials. This tool allows to quickly evaluate the required element size to model a particular frequency. Figure 8.6 shows an example for the acoustic component.

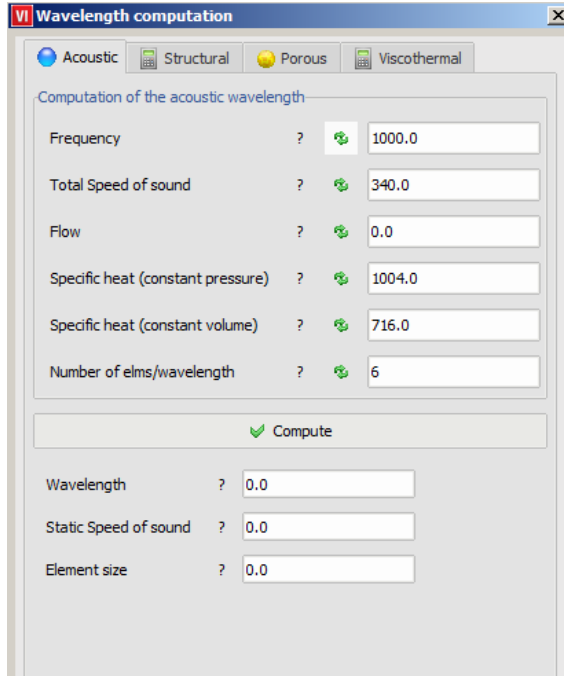

Figure 8.6: Wavelength computation utility

8.4.2 Fluxes Computation tool

This tool allows to compute the average and total flux on a PID domain and the local, average and total flux flowing through the interface between two PID domains. Table 8.1 shows the quantities computed by the Fluxes Computation tool.

Quantity identifier	Quantity name
itf_*	Interface flux: the flux through the interface between 2 elements
total_itf_*	Total interface flux: the total flux through the interface between 2 PID domains
avg_itf_*	Average interface flux: the average flux through the interface between 2 PID domains
total_*	Total domain flux: the total flux on a domain
avg_*	Average domain flux: the average flux on a domain

Table 8.1: The results output by Fluxes Computation tool. * is the field name.

For the case of the vibrational intensity computed by the `NAS_POSTPRO` utility, for example, all quantities are output as total value; divided into membrane, bending and transverse shear or their combination. For `PSOLID`, only total value is computed. The different components output for the vibrational intensity by Fluxes Computation tool are then as listed in Table 8.2.

Component identifier	Component name
*	Total value
*_bend	Bending
*_memb	Membrane
*_trans_shear	Transverse shear
*_bend_trans_shear	Bending + transverse shear
*_memb_bend	Membrane + bending
*_memb_trans_shear	Membrane + transverse shear

Table 8.2: The components can be output for a quantity by Fluxes Computation tool. * is the quantity identifier (see Table 8.1)

- **total_flux** The total flux on group of elements (grouped by PID) is computed as the following equation:

$$total_flux = \sum_i flux_i \cdot V_i$$

Where:

- $flux_i$ is the flux on element i

- V_i is the volume of element i
- **avg_flux** The average flux on group of elements (grouped by PID) is computed as the following equation:

$$avg_flux = \sum_i flux_i * (\frac{V_i}{\sum_i V_i})$$

Where:

- $flux_i$ is the flux on element i
- V_i is the volume of element i
- **itf_flux** The flux through the interface between two elements is computed by averaging the flux $flux$ projected on the normal of the interface.

$$itf_flux = \frac{flux_1.area_1.\vec{n} + flux_2.area_2.\vec{n}}{area_1 + area_2}$$

Where $area_1$ and $area_2$ are the cross areas of element 1 and element 2 at the boundary. For example, for 2D elements:

$$area_1 = interface_length.thickness_1$$

$$area_2 = interface_length.thickness_2$$

Remarks:

- itf_flux is not computed if there are more than 2 neighboring elements at the interface.
- itf_flux is computed using only the $flux$ of the element which has the dimension of the dimension of the interface +1.
- **total_itf_flux** The flux through the interface between two groups of elements is computed by integrating the itf_flux over the interface between 2 PID domains.

$$total_itf_flux = \sum_i itf_flux_i.area_i$$

Where $area_i$ is the average cross area of 2 neighboring elements at interface i . For example, for 2D elements:

$$area_i = interface_length_i.(thickness_{i1} + thickness_{i2})/2$$

- **avg_itf_flux** The average flux through the interface between 2 groups of elements is computed by dividing the $total_itf_flux$ by the total area.

$$avg_itf_flux = \frac{total_itf_flux}{\sum_i area_i}$$

Where $area_i$ is the average cross area of 2 neighboring elements at the interface i .

The input files for flux computation by the Fluxes Computation tool of the vibrational intensity computed by the `NAS_POSTPRO` utility, for example, are:

- the NFF database containing the vibrational intensity on elements computed by the `NAS_POSTPRO` utility
- and the mesh file in any supported format. The element groups can be created automatically based on number of elements by using the Split function in the Meshing tool.

Figure 8.7 shows the procedure to compute the vibrational intensity in ACTRAN .

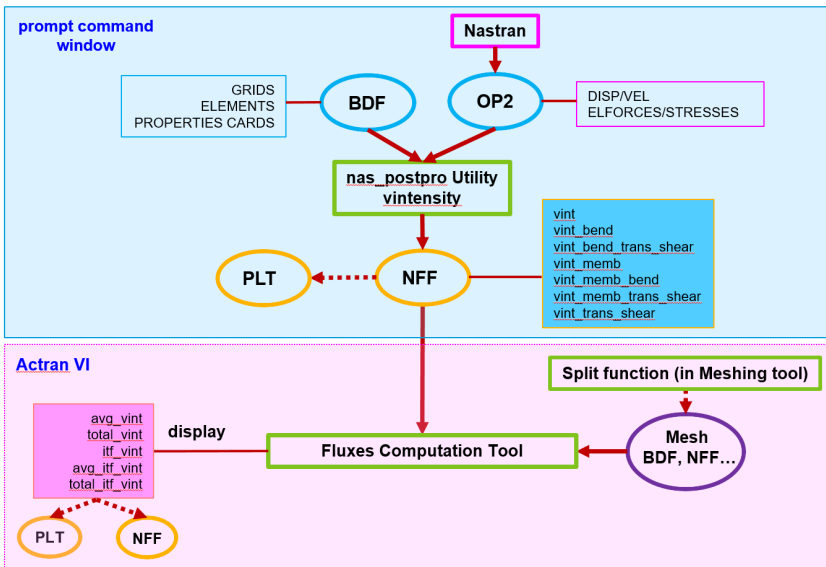

Figure 8.7: The procedure to compute the vibrational intensity

8.4.3 Nastran Post Processing tool

This tool allows to compute particular fields (e.g. vibrational intensity) from Nastran outputs by the `NAS_POSTPRO` utility in ActranVI. Figure 8.8 shows an example.

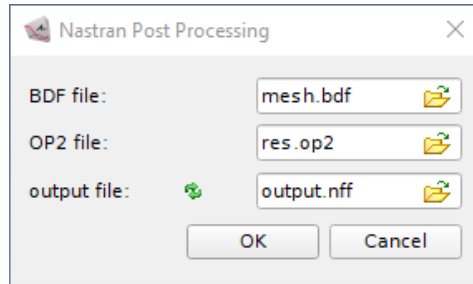

Figure 8.8: Nastran Postprocessing Utility

Where:

- `mesh.bdf` the structure mesh stored in BDF format
- `res.op2` the results stored in OP2 format
- `output.nff` is the name of the output file in ACTRAN NFF format. If not specified, the output NFF database will have the same radical name than the OP2 NASTRAN results file

This tool is used to run the `NAS_POSTPRO` utility inside ActranVI, refer to Section 58.18 of Volume 1 for more information about its usage.

8.4.4 RPM Computation tool

This computational tool allows to compute Rotation per minute(RPM) and tread passing frequency for a tire based on time period of revolution and tire size information. This tool allows to quickly evaluate the RPM, number of treads and tread passing frequency of a particular tire. Figure 8.9 shows an example of RPM computation tool.

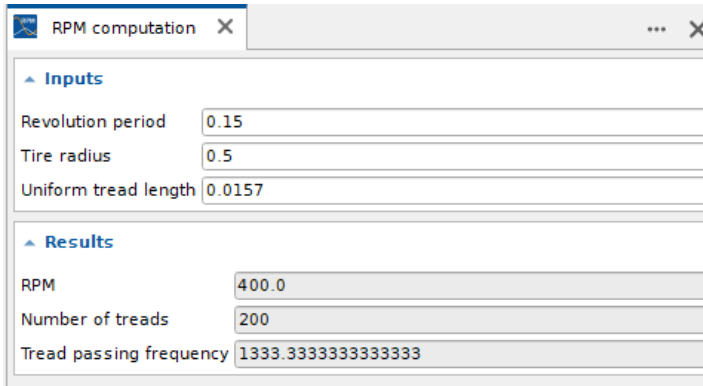

Figure 8.9: RPM computation tool

8.5 "Utilities" menu

Figure 8.10 shows the functions that can be accessed through the Utilities menu.

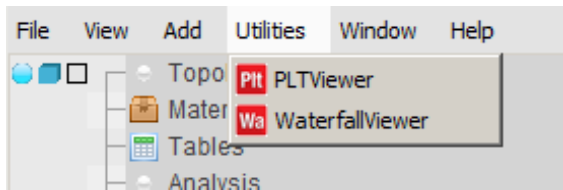

Figure 8.10: Utilities menu in ACTRANVI

8.5.1 PLT Viewer

Open a PLTVIEWER application in a new tab (Chapter 16).

8.5.2 Waterfall Viewer

Open a WATERFALLVIEWER application in a new tab (Chapter 22).

8.6 "Window" menu

Figure 8.11 shows the functions that can be accessed through the Window menu.

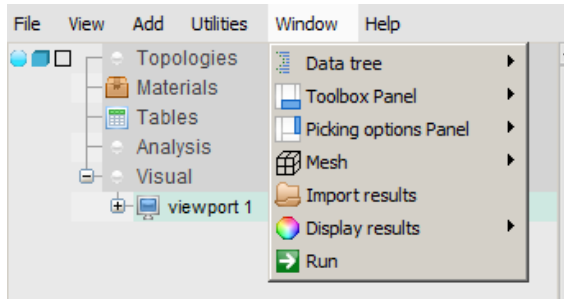

Figure 8.11: Window menu in ACTRANVI

- **Data tree:** The Split function splits the Data tree panel into the main data tree panel and the data tree sub-panel. The Merge function hides the data tree sub-panel. Refer to Chapter 10 and Section 10.1.4;
- **Toolbox panel:** The Show and Hide functions respectively show and hide the Toolbox panel (Chapter 11);
- **Selection panel:** The Show and Hide functions respectively show and hide the Element Selection panel (Chapter 12);
- **Mesh:** Provides a direct access to the Mesh Tab of the Toolbox. Refer to Section 11.1;
- **Import results:** This function is the link to the Import results tab in the Toolbox. Refer to Section 11.2;
- **Display results:** The four functions (Visualization, Animation, Properties, Cutplane) are the links to the corresponding tabs in Display results in the Toolbox. Refer to Section 11.3;
- **Run:** The Run function is the link to the Run tab in the Toolbox. Refer to Section 11.4;

8.7 "Wizards" Menu

Figure 8.12 shows the functions that can be accessed through the Wizards menu.

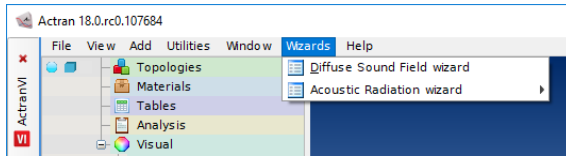

Figure 8.12: Wizards menu in ACTRANVI

8.7.1 Diffuse Sound Field Wizard

The Diffuse Sound Field wizard provides a clearly defined, 5-step process that allows the user to create and run a Direct Frequency Response using the Diffuse Sound Field Boundary Condition in ACTRAN . All the components needed for the analysis are created automatically by the wizard based on the user's inputs. At the end of the wizard, the user may directly run the analysis. When the wizard is closed, the user is given the possibility to save or discard the analysis. By saving the analysis, the user can later perform additional manual operations. If the user chooses to discard the analysis created by the wizard, the analysis is deleted.

8.7.2 Acoustic Radiation Wizard

The Acoustic Radiation wizard provides a clearly defined, 5-step process that allows the user to create an Acoustic Radiation Analysis and works in an identical way as the Diffuse Sounds Field wizard. The wizard is further subdivided into three different parts where each corresponds to a different type of analysis:

- The **Frequency Acoustic Radiation wizard** creates a direct frequency response.
- The **Time Acoustic Radiation wizard** creates a time domain analysis.
- The **Green Acoustic Radiation wizard** creates a Green analysis.

8.7.3 EA damping Optimization Wizard

The EA damping optimization wizard provides a process to generate an optimization script to identify the patches on which it is optimal to apply damping pads. It generates an EA Analysis excited by a diffuse sound field with the localisation of the surface to be optimized. An optimization script is generated and can be run inside ACTRANVI to obtain to best patches to be treated. These patches can be visualized inside ACTRANVI and the corresponding squared normal velocity of the untreated, fully treated and optimally treated configuration can be visualized inside the PLTVIEWER.

8.7.4 SEA model building from TL data Wizard

The SEA model building from TL data wizard provides a clearly defined 6-step process that allows the user to create a functional SEA model of cavity subsystems. Those subsystems will be linked and/or excited by panels, which are defined by their Transmission Loss (TL) and absorption coefficient data. The Coupling Loss Factor (CLF) between two cavities is computed from the TL value of the panel linking them, and the Damping Loss Factor (DLF) of a single cavity is computed from the absorption coefficients of all its neighboring panels. The model can be loaded either by injecting a power in a cavity subsystem, or by specifying squared pressures on exterior panels. Energetic results in each cavity subsystem are produced and can be visualized inside PLTVIEWER.

8.8 "Help" menu

Figure 8.13 shows the functions that can be accessed through the Help menu.

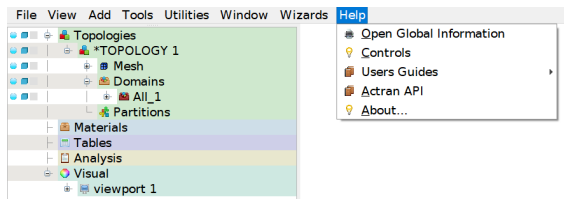

Figure 8.13: Help menu in ACTRANVI

8.8.1 Users Guides

The user can access to the User's Guide of ACTRAN and the User's Guide of ACTRANVI.

8.8.2 ACTRAN API

The user can access the documentation of the ACTRAN API.

8.8.3 Open Global Information file

Allows to open a global information file generated during an ACTRAN computation. More information on this file can be found in Section 12.2.4 of Volume 1.

8.8.4 Controls

This provides a description of the different mouse and keyboard shortcuts in the [Render window](#). Please refer to Chapter 9 for more detailed descriptions.

8.8.5 About...

Information related to the ACTRANVI application and to the computer's environment.

8.9 Settings

The settings of the ACTRANVI application can be modified in a window accessible through the File menu. Note that changing some settings may require a restart of the application before they are properly taken into account.

8.9.1 General

Figure 8.14 shows the General tab of the ACTRANVI Settings. Additional information on some of these options is given below.

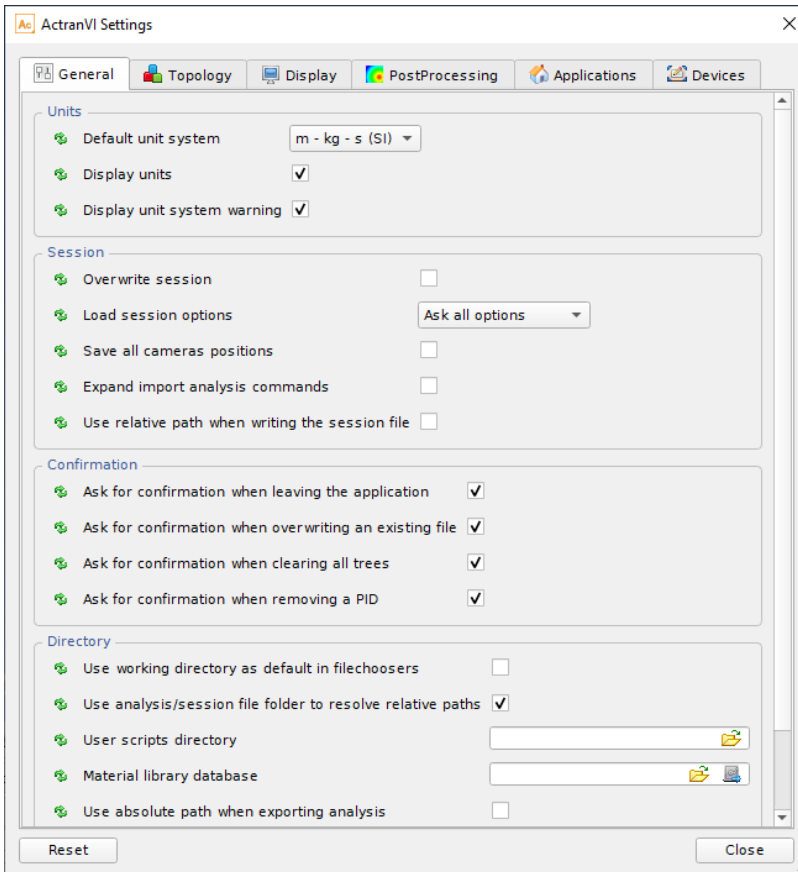

Figure 8.14: ACTRANVI Settings: General

Units

- The "Default unit system" setting determines the length unit of the visualization in ACTRANVI, and is used as a default value to initialize the unit

system of analyses, topologies, materials and tables when no information is available. More detailed information can be found in Chapter 14.

- The checkbox "Display units" (checked by default) activates the display of units within ACTRANVI, in particular the units of any property with a physical dimension in the property windows.
- The checkbox "Display unit system warning" (checked by default) activates the display of a warning message when importing an analysis without a unit system definition. The message states that the analysis unit system will be initialized following the "Default unit system" setting. The user can disable this warning at any time, either from the settings or directly from the warning window.

Session:

- **Overwrite session:** when this box is checked, the automatically saved session file of an ACTRANVI application overwrites the previous session file. This session file is stored in the directory from which ACTRANVI is launched. On Windows platforms, an ACTRANVI application launched via the Start menu is launched in its "Start in" directory. This "Start in" directory can be found in the Properties of the ACTRANVI application link in the Windows Start menu, shown in Figure 8.15.
User should avoid working with more than one ACTRANVI applications while this option is checked. By default, this option is not checked;
- **Save all camera positions:** when this option is checked, all changes of camera positions are saved in the session file. When un-checked, camera positions are saved only before exporting an image, exporting a [session](#) or launching an animation in [Display results](#) tab. By default, this option is not checked;
- **Expand import analysis commands:** allows selecting a short or long description of the input of an analysis. By default the "Short" format is selected;
- **Use relative path when writing the session file:** Path to imported or exported files are written in the session file using relative path instead of absolute path by default.
- **Ask for confirmation:** Allows to put or remove popup windows associated to checks occurring when performing various operations in the graphical user interface.
- **Use working directory as default in filechoosers:** When activated, the filechoosers windows (e.g. Import Mesh, Import Analysis) is opened in the

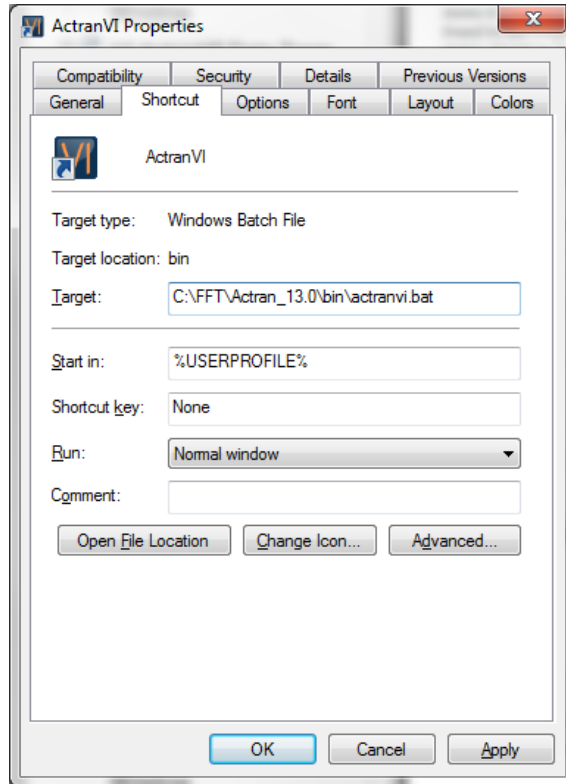

Figure 8.15: ACTRANVI "Start in" directory in Windows

current working directory and not in the directory where the last file was imported.

- User scripts directory: When a directory is specified, an additional "User's scripts" menu appears in PLTViewer. From this menu, all Python (.py) and session (.sess) files located in the specified directory can be run.
- Material library database: the user can select, remove and backup the material library database folder;
- Splashscreen: Allows to display or hide the splashscreen at application startup.

8.9.2 Topology

Figure 8.16 shows the Topology tab of the ACTRANVI Settings. Additional information on some of these options is given below.

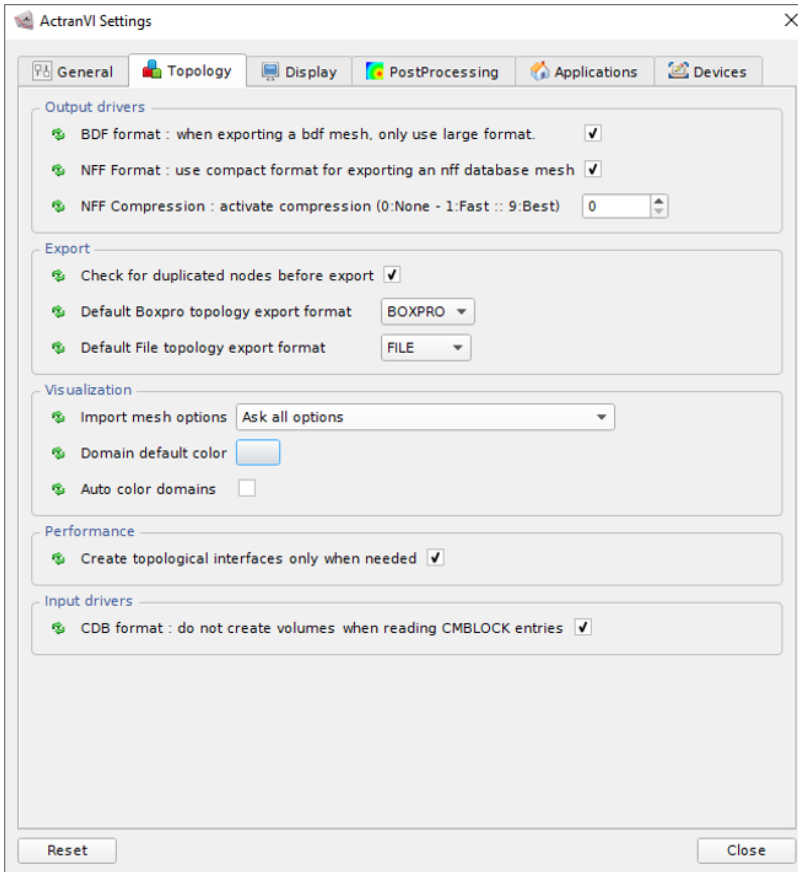

Figure 8.16: ACTRANVI Settings: Topology

- The option "BDF format: when exporting a BDF mesh, only use large format", when selected, will output BDF files in large format. Exporting in large format may be necessary (large node or element numbering) but will create larger files.
- The option "NFF Format: use compact format for exporting an nff database mesh", when selected, the exported NFF files will be output in compact format, allowing to output smaller files.
- The NFF format can be compressed further in order to save space. By default, no compression is applied. The user can apply the desired level of compression by specifying it on a scale from 1 to 9, with one being the fastest possible and 9 being the best possible.
- The option "Check for duplicated nodes before export" activates the check

in the exported analysis or mesh of nodes separated by a smaller distance than the specified topology tolerance.

- **BOXPRO** topologies are exported by default to the ACTRAN input file. Two options are available: **BOXPRO** format (refer to Section 10.3.12 and to ACTRAN User's Guide Section 5.6 of Volume 2) and ACTRAN mesh format.
- **File topologies default export format**: specifies how the File topologies are exported by default to the ACTRAN input file. Two options are available: **File format** (refer to Section 10.3.6 and to ACTRAN User's Guide Section 5.6 of Volume 2) and ACTRAN mesh format.
- **Import mesh options**: if set to "Ask all options", when loading a mesh file, a dialog box appears with options specific to the mesh format of the imported mesh. There is a common option to all mesh format : "Display mesh", which allows the user to display the mesh or postpone this display. If the "Import mesh options" is set to "Display mesh (use default for other options)"/"Don't load mesh (use default for other options)", then the dialog box does not appear, the "Display mesh" option is on/off so the mesh is displayed/not displayed. In both cases, all others options specific to the imported mesh format are set to their default value.
- **Visualization, Domain default color**: this option sets the default color of any **PID Domain** when it is imported or created in ACTRANVI. Refer to the Section data tree **visibility** (Section 10.1.1) for more information.
- **Performance, Create topological interfaces only when needed**: when this option is checked, the topological interfaces construction is performed only when necessary. When checked, this option improves the performance of ACTRANVI.
- **CDB format**: do not create volumes when reading **CMBLOCK** entries. When this option is selected, the CDB input driver does not create volume elements for **CMBLOCK** entries. The users can then use the **CMBLOCK** block for supporting the boundary conditions.

8.9.3 Display

Figure 8.17 shows the Display tab of the ACTRANVI Settings.

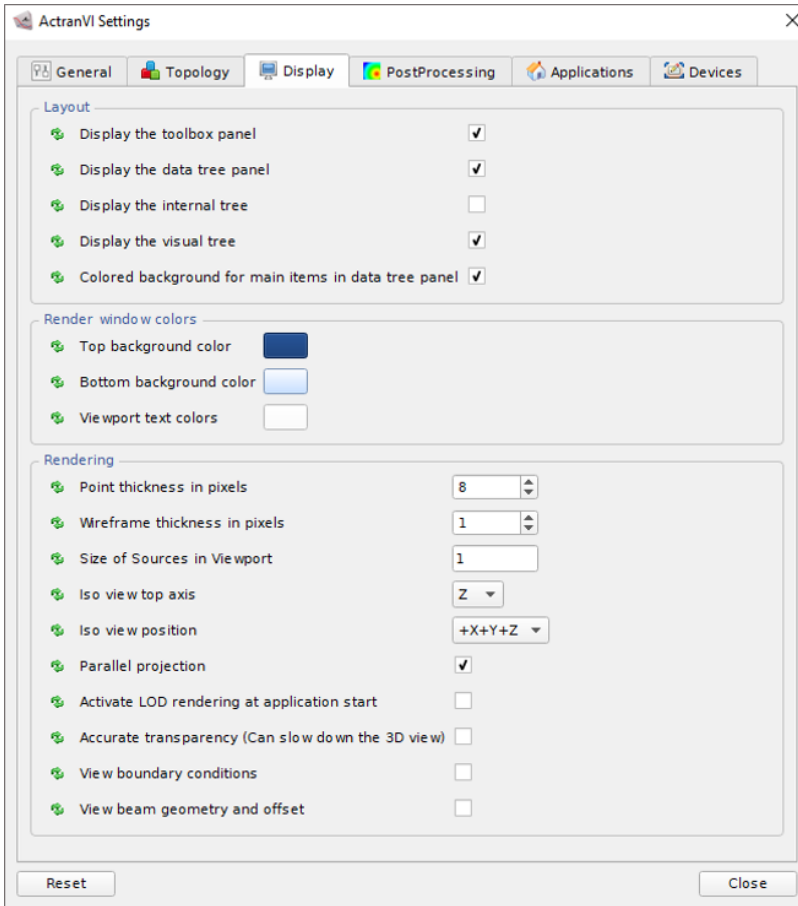

Figure 8.17: ACTRANVI Settings: Display

- The Layout options configure the start-up layout of the application;
- The Render window colors set the default colors of the render window together with the text color in the window;
- The Rendering options set the default rendering methods. When Parallel Projection method is unselected, the projection method is switched to Isometric projection. The Reset Camera Clipping option, when selected, resets the render window camera after each mesh operation;
- The Size of Sources in Viewport option allows to assess a global scaling factor for the visualization of spherical, cylindrical and planar sources
- The Point thickness in pixels option allows modifying the rendering size of

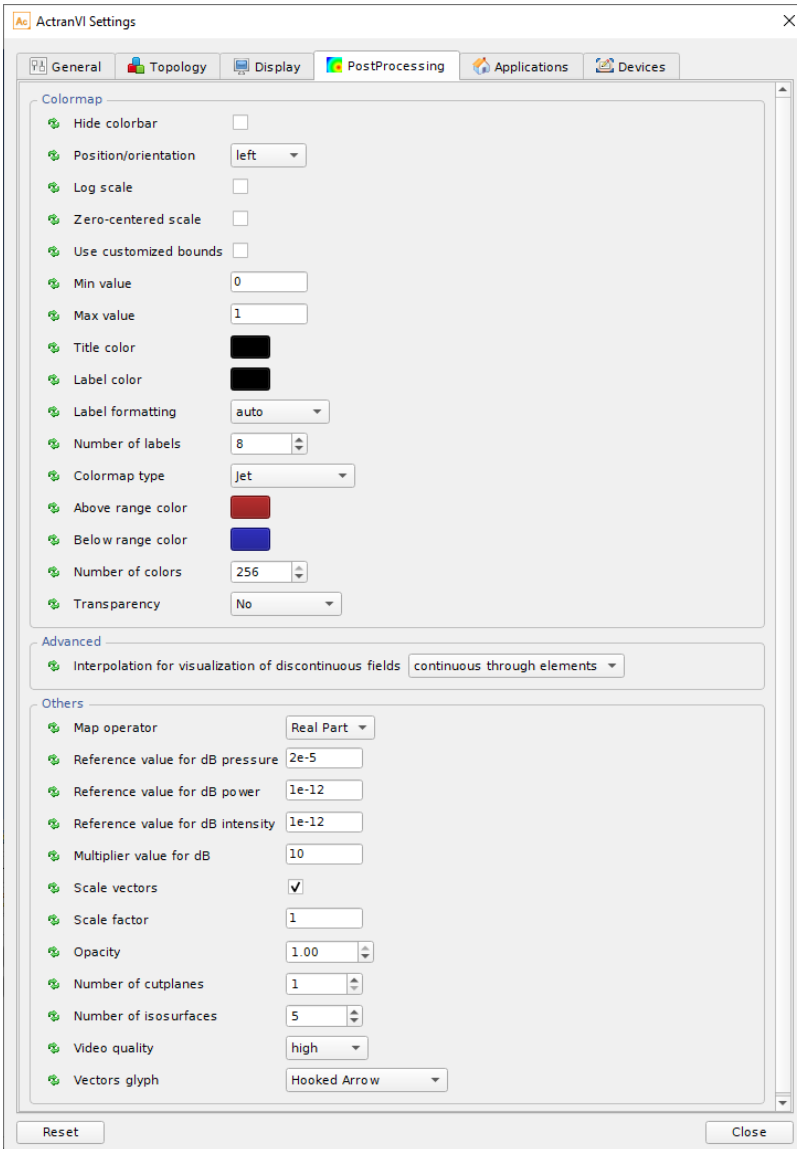

Figure 8.18: ACTRANVI Settings: Post Processing

- Reference value for dB pressure: user can specify a reference value to plot pressure color maps in dB;
- Reference value for dB power: user can specify a reference value to plot power color maps in dB;
- Reference value for dB intensity: user can specify a reference value to plot

intensity color maps in dB;

- Multiplier value for dB: user can specify a multiplier value to plot a color map in dB. This can be used to deal with quadratic values;
- The formulation of the dB operator used in ACTRANVI is:

$$\text{Multiplier} \log \frac{\text{value}^2}{\text{value}_{\text{reference}}^2};$$
- Other configurations in the Post Processing tab set the default settings for the results visualization. More information can be found in the section [View results](#).

8.9.5 Applications

Figure 8.19 shows the Applications tab of the ACTRANVI Settings.

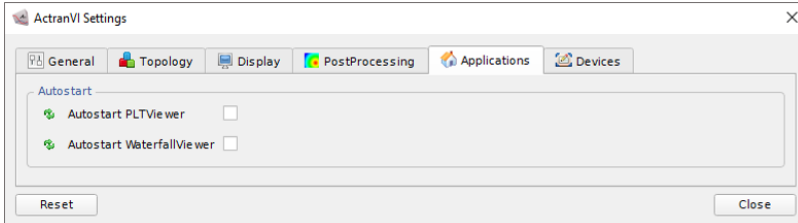

Figure 8.19: ACTRANVI Settings: Applications

- Autostart PLTViewer : start automatically the PLTVIEWER with ACTRANVI;
- Autostart WaterfallViewer : start automatically the WATERFALLVIEWER with ACTRANVI.

8.9.6 Devices

Figure 8.20 shows the Devices tab of the ACTRANVI Settings.

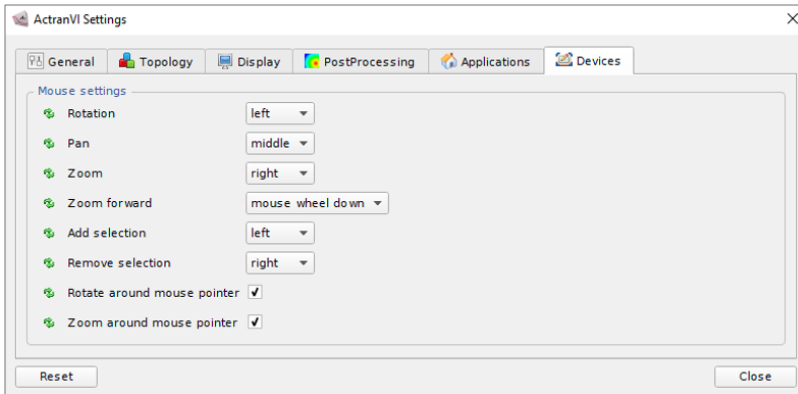

Figure 8.20: ACTRANVI Settings: Devices

- Mouse settings : the mouse buttons can be remapped

8.9.7 Remarks and Further Reading

- The user needs to restart the ACTRANVI application in order to apply the changes in the Settings;
- All the setting options have default values. These default values can be restored by clicking on the green icons on the line of the option;
- Avoid changing background colors in presence of mesh loaded in ACTRANVI, as this may take a long time for the window to refresh.

ACTRANVI Render Window

The render window (Figure 9.1) is the window in which the model is displayed.

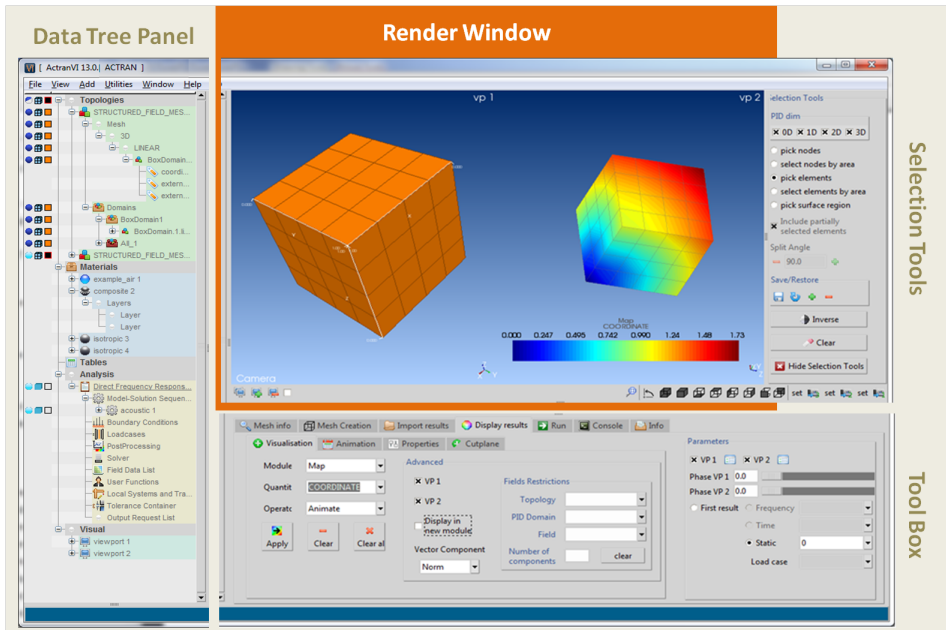

Figure 9.1: Render window of ACTRANVI

The render window contains one or multiple **viewports**.

The background color and the color of the text in the render window can be edited in the [settings](#).

9.1 Mouse and Keyboard Render Window Controls

The different view, selection, tree, console mouse and keyboard controls are listed in the Controls Information that can be displayed from ACTRANVI Help menu.

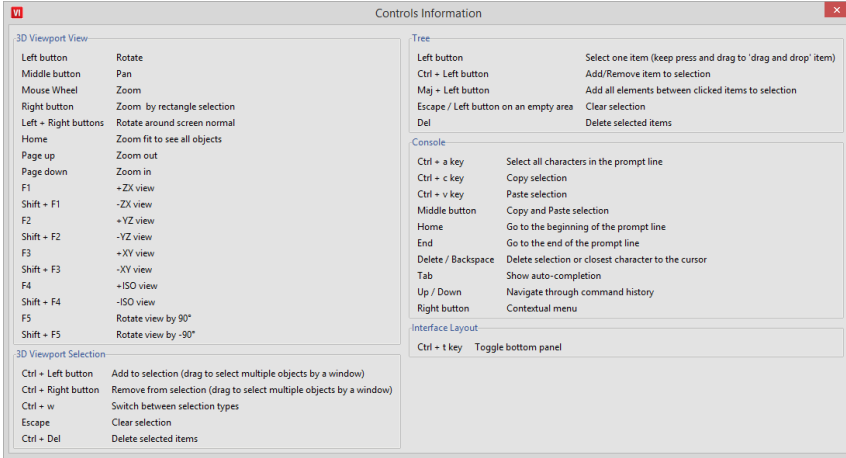

Figure 9.2: Controls of ACTRANVIRender Window

9.2 Render Window Controls

The various icons placed at the bottom right of the [render window](#) represent various shortcuts to ease the visualization. They contain user-customized views (right hand sided buttons) and predefined views perpendicular and ISO views. Specific camera settings (zoom, angle of view and position) can also be saved within Custom Views. Other Visualization tools are also available, such as the 90 degree rotating command and a zoom extend feature.



Figure 9.3: Render window controls

9.3 Viewport

The [render window](#) is controlled by the different viewports, which define the content to be visualized.

Figure 9.4 shows an example of 4 different viewports in the [render window](#).

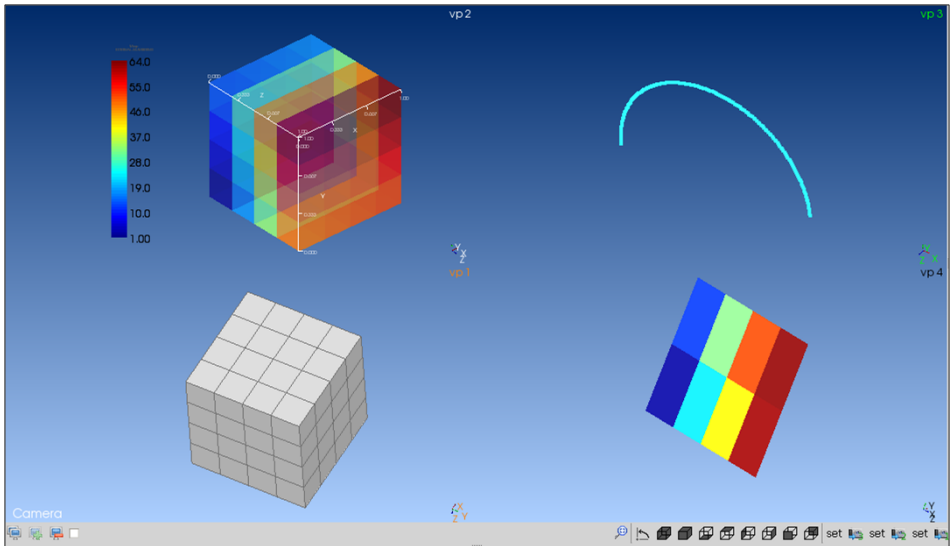

Figure 9.4: An example of four viewports in ACTRANVI

The viewports parameters can be shown in the [visual](#) sub-tree of the [data tree](#) panel (Figure 9.5). Refer to Section 10.8 for more information on the Visual tree.

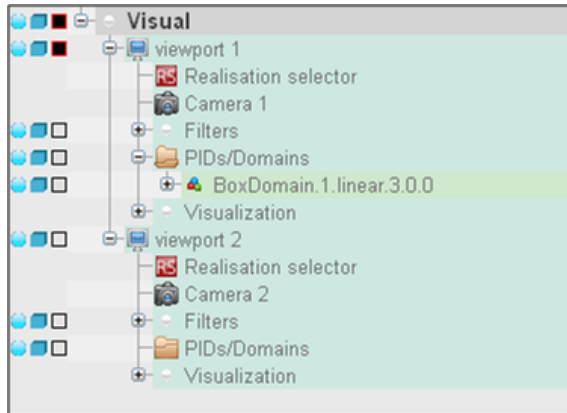

Figure 9.5: Viewport shown in data tree

The [visual](#) tree is hidden by default in ACTRANVI. It can be shown by changing the default option in the [settings](#) (Display tab).

9.3.1 Viewport control

Below the [render window](#), the viewport control bar (Figure 9.6) is used to perform the following operations (ordered according to the position of the buttons from left to right in the control bar):

- Enable/disable the display of only the first viewport;
- Add a new viewport;
- Add a clone viewport;
- Remove an existing viewport;
- Synchronize/desynchronize the camera views of all the different viewports;
- Export viewport to image;
- Copy the viewport to clipboard;
- Enable/disable viewport fast rendering.



Figure 9.6: Viewport control bar

9.3.2 Viewport configuration

Each viewport is characterized by its own properties, which can be accessed by right-clicking on the viewport in the [visual](#) tree. The viewport properties window is shown in Figure 9.7.

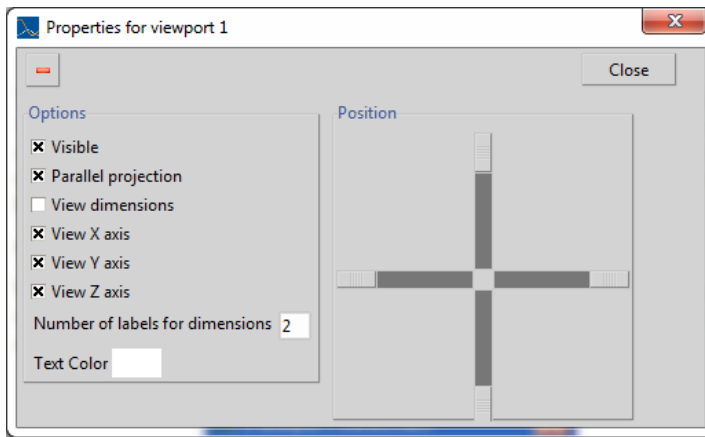

Figure 9.7: Viewport options.

The visibility, the position and the size of the [viewport](#) can be edited. By adjusting the positioning bars, different viewports can also overlap each other. The three dimensions along X, Y and Z axes of the model contained within the viewport can be visualized and edited. The color of the text shown in a viewport can also be changed.

When the Parallel projection option is ticked off, the Isometric perspective is activated.

Figure 9.8 shows the two different perspective views on the same mesh in ACTRANVI.

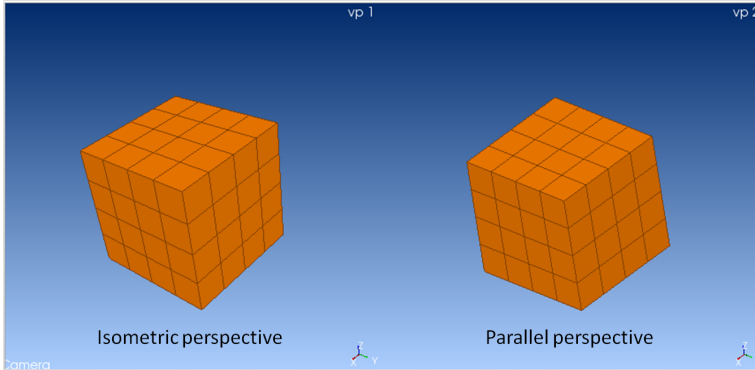

Figure 9.8: Parallel perspective and Isometric perspective in ACTRANVI

9.3.3 Viewport contents

When a mesh is imported or created in ACTRANVI application where multiple viewports are present, a pop-up appears to select the viewport(s) where the mesh should be displayed. This is shown in Figure 9.9. In the pop-up window, the user can also create a new viewport to place the mesh.

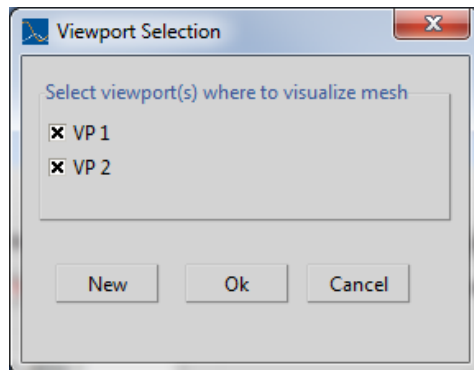

Figure 9.9: Selection viewport(s) to contain mesh

A [PID](#) or a [Domain](#) can be displayed in a viewport via the [drag'n'drop](#) operation. Figure 9.10 shows the drag'n'drop operation to display a [PID](#) in a viewport. Figure 9.11 shows the drag'n'drop operation to display a [Domain](#) in a viewport.

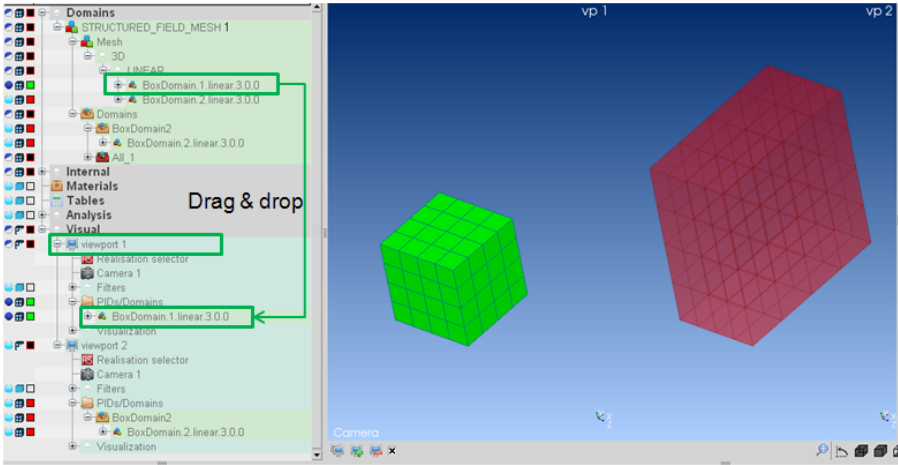

Figure 9.10: Associate a PID with a viewport via drag'n'drop

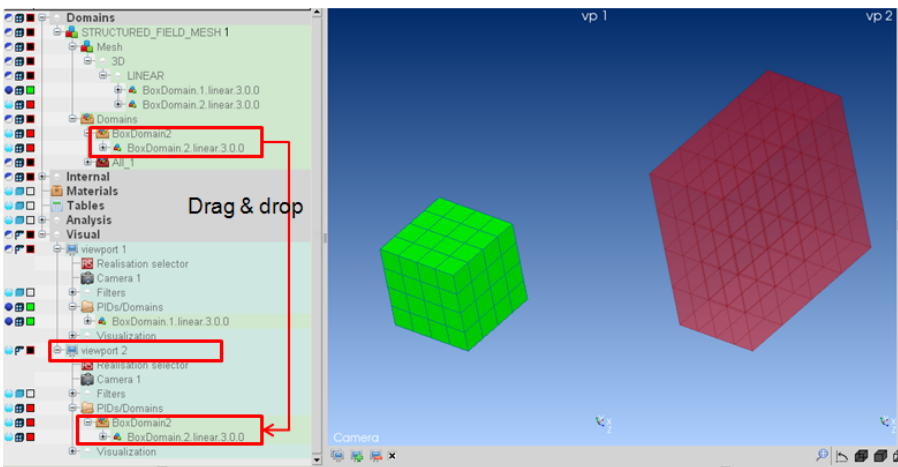

Figure 9.11: Associate a Domain with a viewport via drag'n'drop

In order to remove a PID or a Domain from a viewport, one can select the item to be removed from a specific viewport in the **visual** tree and use the Delete key or the Remove function in the right click menu (Figure 9.12).

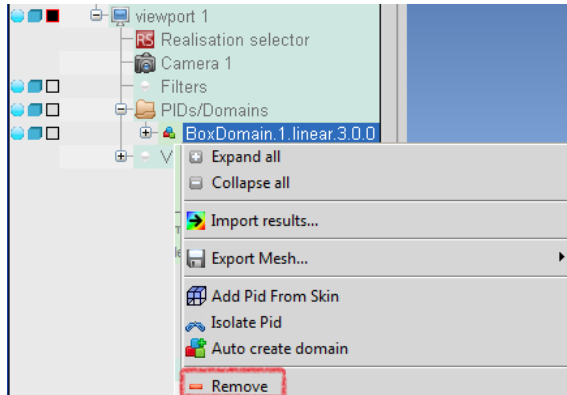

Figure 9.12: Remove a PID form a viewport

9.3.4 Exploded View

The exploded view function allows to visualize all element sets of the viewport separately. The exploded view is creating by translating the element sets in the following way: the distance from the point defined by the Origin parameter and an element set is projected on each global axis and multiplied by the scale factor corresponding to this axis. Furthermore, the "Group by domain" option allows to create an exploded view relative to the domains instead of the elements sets.

9.4 Remarks and Further Reading

- The maximum number of viewports supported in ACTRANVI is 4;
- The cameras of different viewports can be synchronized individually in the [Visual](#) tree (refer to Section 10.8.1).

ACTRANVI Data Trees

The data tree panel is the left part of the ACTRANVI interface (Figure 10.1). The data tree panel is made of five main trees:

- [Topologies](#) tree;
- [Material](#) tree;
- [Table](#) tree;
- [Analysis](#) tree;
- [Visual](#) tree.

The optional trees are not shown by default. They can be activated via the [settings](#).

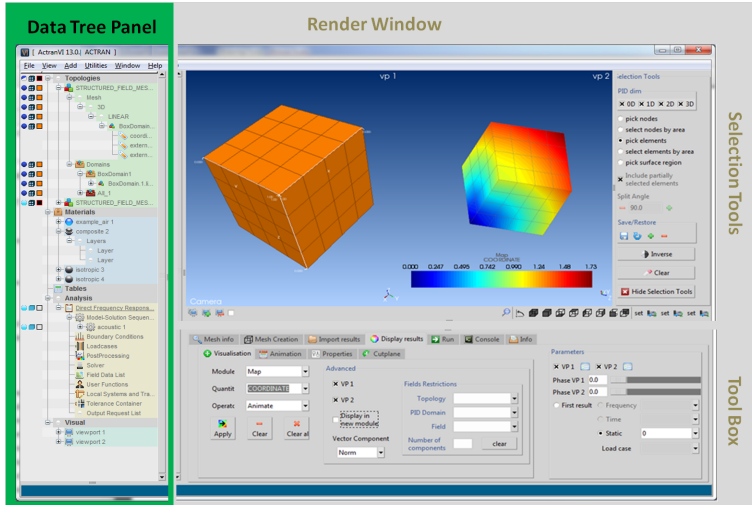

Figure 10.1: The Date Tree Panel in ACTRANVI

10.1 Data Tree Node

A data tree node (or item) is represented as a line in the data tree panel. It can be a **topology**, a **material**, an **analysis**, or a flow **field** under a finite fluid **component**, etc. A node can contain several levels of children nodes. Figure 10.2 shows an example of the data tree nodes.

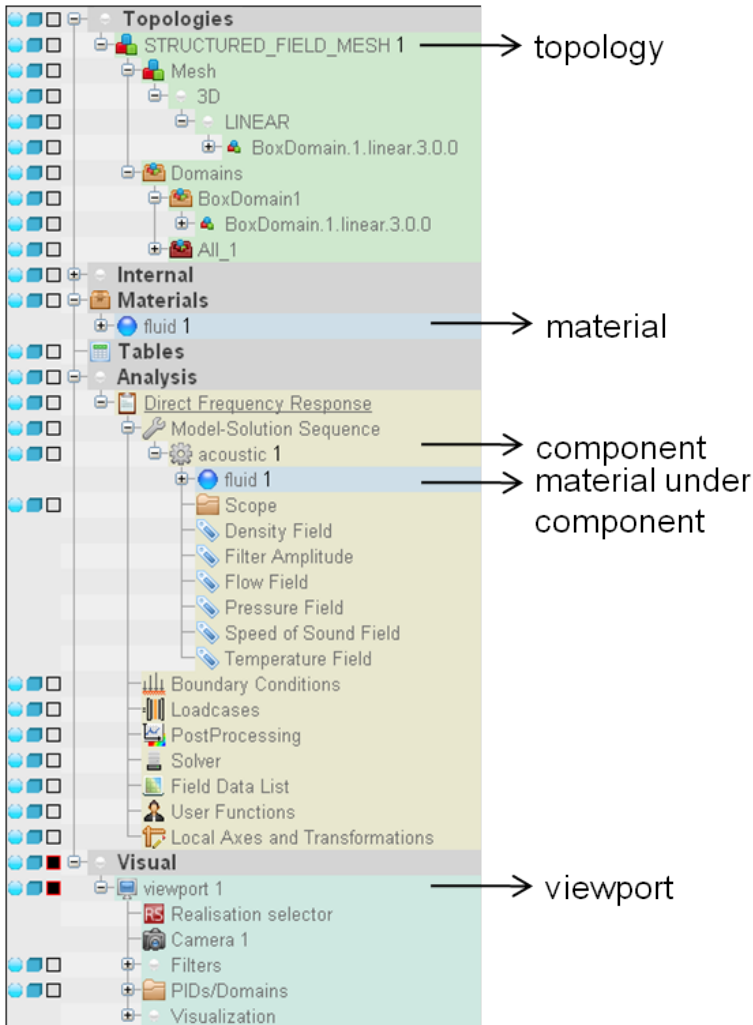

Figure 10.2: The data tree nodes

10.1.1 Data Tree Node Visibility

A set of three icons appears on the left side of any node that may be displayed in the [render window](#) (Figure 10.3). Clicking on the first icon modifies the transparency of the related finite elements which changes from semi-transparent (default, icon's color is light-blue) to opaque (icon turns dark-blue) to fully-transparent or hidden (icon turns white) then back to semi-transparent. The transparency state is applied to the selected data tree node but also to all related nodes. Right-clicking on it will allow to directly set the transparency state and set the opacity value..

The second graphical icon controls the display of the element edges. Clicking on this icon will cycle between three options: surface only, wireframe only, surface and wireframe. Right-clicking will allow to directly set the option.

The third graphical icon may be used to change the color of the related objects.



Figure 10.3: Graphical icons controlling the display of any node of a graph

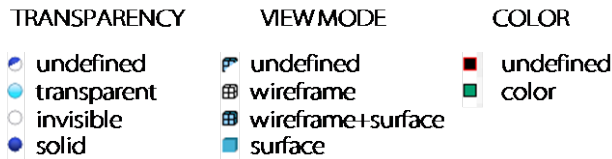

Figure 10.4: Graphical icons options



Figure 10.5: Use of the graphical icons options

Click [here](#) to see a video example.

10.1.2 Data Tree Node Right Click Menu

Right-clicking on a data tree draws a menu. The menu shows all the functions/operations related to this node (Figure 10.6). The most commonly used functions/operations are:

- Expand all: expand fully the node and all its children nodes;
- Collapse all: fold fully the node;
- Remove: delete the node;

- Duplicate: duplicate the node in its parent node;
- Properties...: access to the [property window](#) of the node.

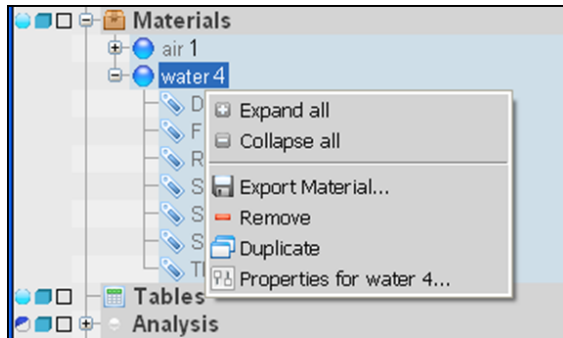

Figure 10.6: Right click menu of a data tree node

The entire graphical tree can be expanded and collapsed at once by using the shortcuts 'CTRL +' and 'CTRL -' respectively. The 'CTRL' and '+/-' buttons need to be pressed together after clicking on the graphical tree.

10.1.3 Data Tree Node Drag'n'Drop

Some of the data tree nodes can be drag-and-dropped to other data tree nodes. The drag'n'drop can also be used to associate items located in different panels. To drag'n'drop item 1 to item 2, the operation is performed using the mouse, in three steps:

- left click on the item 1;
- hold the left button of the mouse while displacing item 1 towards item 2;
- release the left button when item 1 arrives over item 2

Figure 10.7 illustrates the drag'n'drop of a [domain](#) into the scope of a [component](#).

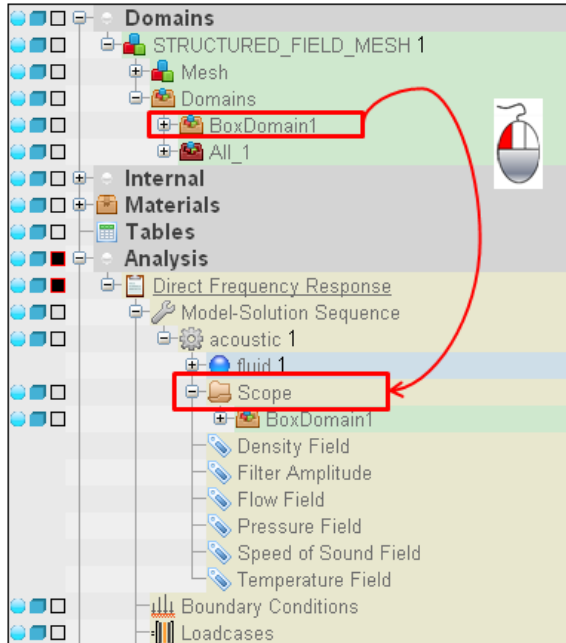

Figure 10.7: A drag'n'drop operation

Figure 10.8 illustrates the drag'n'drop of a coupling surface into a BC_MESH.

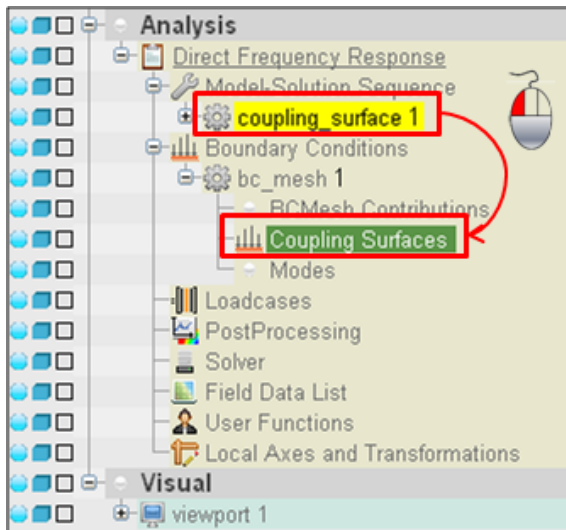

Figure 10.8: A drag'n'drop operation

Click [here](#) to see a video example.

An alternative to the drag'n'drop is the [Scope selector](#). Refer to Section [10.2.8](#) for more information.

10.1.4 Data Tree Sub-Panel

The data tree sub-panel allows the user to focus on a particular [data tree node](#). It is a container for all the children data tree nodes of a selected data tree node.

The data tree sub-panel is a window below the main data tree panel. It is hidden as ACTRANVI starts. In order to use this sub-panel, the user needs to use the mouse to bring up the separation bar between the two panels (Figure [10.9](#)).

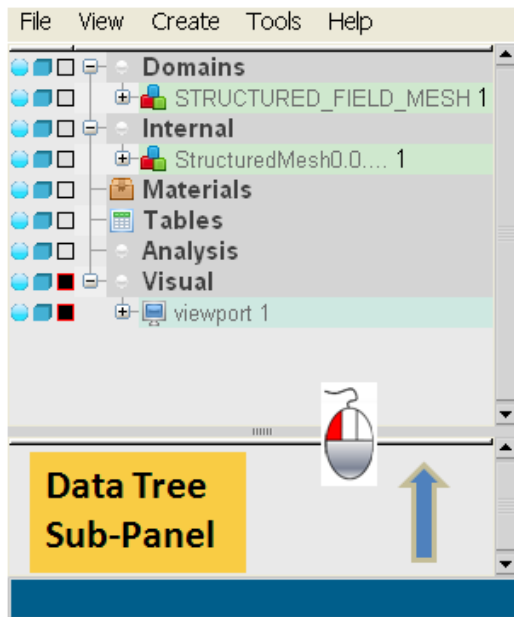

Figure 10.9: Use mouse to show the data tree sub-panel

The user can then [drag'n'drop](#) a [data tree node](#) from the main data tree panel to the sub-panel. When this is done, all the children of that node are shown in the sub-panel. This is shown in Figure [10.10](#)

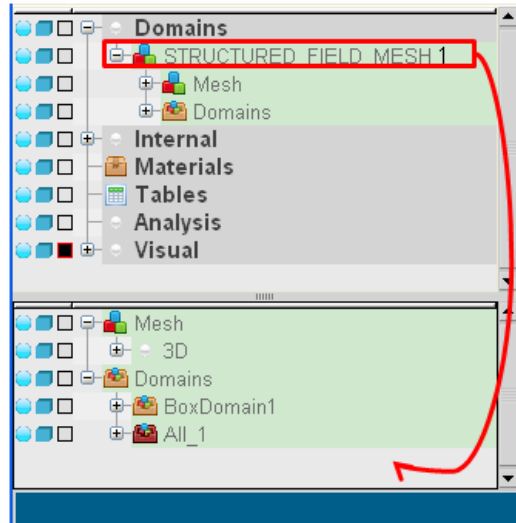

Figure 10.10: Use sub-panel to focus on a data tree node

As shown in Figure 10.10, the visualization of the same node in the main panel and in the sub-panel can be different. The user can develop (unfold) the node in the sub-panel while keeping the same node folded in the main panel.

The contents of the node in the two panels are always synchronized.

Click [here](#) to see a video example.

10.1.5 Remarks and Further Reading

- The [drag'n'drop](#) operation is not the only possibility to associate a [domain](#) with the scope of a [component](#). This can also be done via the [scope selector](#) (Section 10.2.8);
- The [drag'n'drop](#) operation involving two non-associable items has no effect;
- The [drag'n'drop](#) operation can be performed between the main data tree panel and the data tree sub-panel.

10.2 Property Window

The property window shows all the properties related to a [data tree node](#). To access the property window, one can double left-click on the node, or right-click and choose "Properties...", as shown in Figure 10.11.

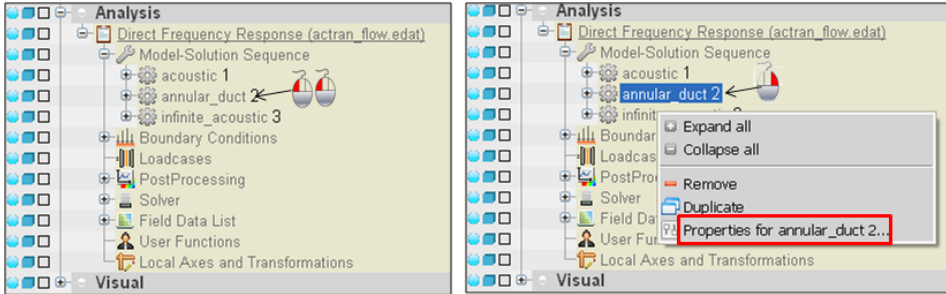

Figure 10.11: Two methods to access to the property window of a data tree node

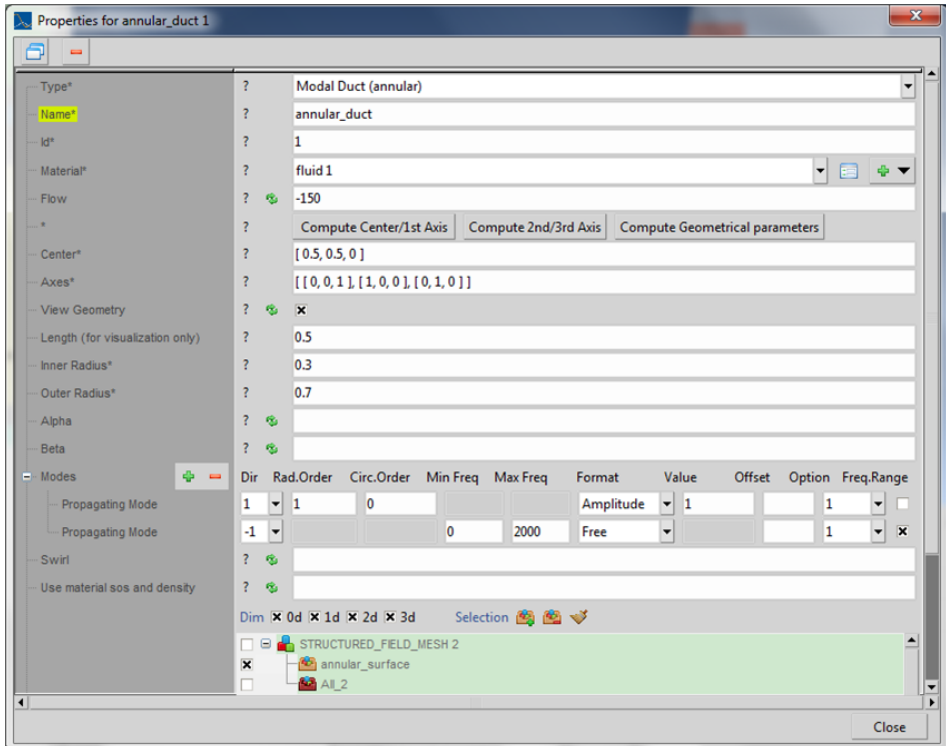

Figure 10.12: Example of a property window

The property window can be edited. The data entered in the property window are used to build the ACTRAN analysis.

10.2.1 Mandatory data

The mandatory data entries required by the property window is marked by a * sign. The optional entries are not marked by the star sign (Figure 10.13).

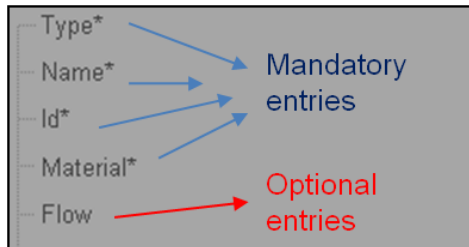

Figure 10.13: Mandatory and optional data entries

10.2.2 Help and default value

Place the mouse on the ? sign, a text appears to explain how to enter the data value. Take the FLOW entry for example (Figure 10.14), the ? sign indicates that the user must enter a real number or the AUTO keyword.

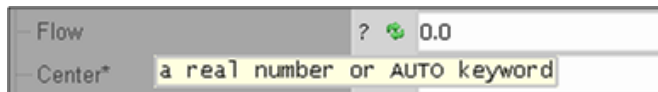

Figure 10.14: Help icon and Default value icon

Below are some complementary explanations on the ? sign text.

- A list: a set of values included between brackets. The values must be separated by commas. The dimension of the list is the number of values in the list. For example, a list of dimension 2 can be [2,5], a list of dimension 3 can be [1,1,10];
- A list (unbounded) of lists: this can be a single list or multiple lists separated by commas. For example: [1,1,10], [16,2,40], [100],[200] is a list of four lists. The four lists are of dimensions 3, 3, 1 and 1 respectively;
- A complex number is entered the following way: $A+Bj$, where A and B are the real part and imaginary part of the complex number;

- A Table + id entry: the data entered can refer to a [TABLE](#). This is done by entering, for example: TABLE 5, where 5 is the ID of the TABLE in the ACTRANVI session

Next to the ? icon, a default value icon appears for all the data lines having a default value. Click on this icon will set the default value for the data entry line.

10.2.3 Toggle down selection and child node creation/edition

Some lines of the property window are edited via the toggle down selection list (Figure 10.15).



Figure 10.15: Toggle down selection

Sometimes the selected item becomes a child of the current [data tree node](#). In this case, two other icons appear on the right of the toggle down list (Figure 10.15). The first icon is used to show/edit the property window of the selected item; the second icon is used to create a new item.

10.2.4 Value and Field entry

Some data lines can be defined by a value or by a [field](#) (Figure 10.16). A value is entered by the user. The value is defined without any spatial variation. The field entry must refer to a pre-defined field. A field defines a spatial variation of the quantity. Refer to the ACTRAN User’s Guide Section 11.9 of Volume 2 for more information on the usage of fields. The definition of [field](#) in ACTRANVI is presented in Section 10.6.11.

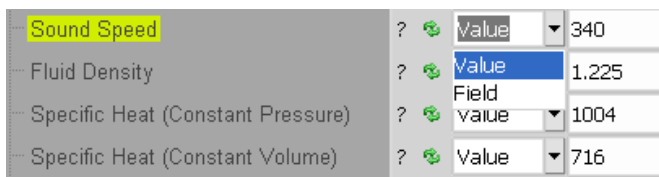

Figure 10.16: Value/Field selection for a data entry line

10.2.5 File chooser

A file chooser in a property window is used to select one or several files. An example of file chooser is shown in Figure 10.17. The selected file(s) can be exported in the main analysis file as INCLUDE_FILE(s) or RESULT_FILE(s).

Different methods are available to display and export the selected file(s):

- If the file chooser button is activated by left-click, the full path and the name of the selected file are displayed. The path relative to the main analysis file is exported in the ACTRAN input file;
- If the file chooser is activated by right-click, only the file's name is displayed (not the path). Only the filename is exported in the ACTRAN input file.

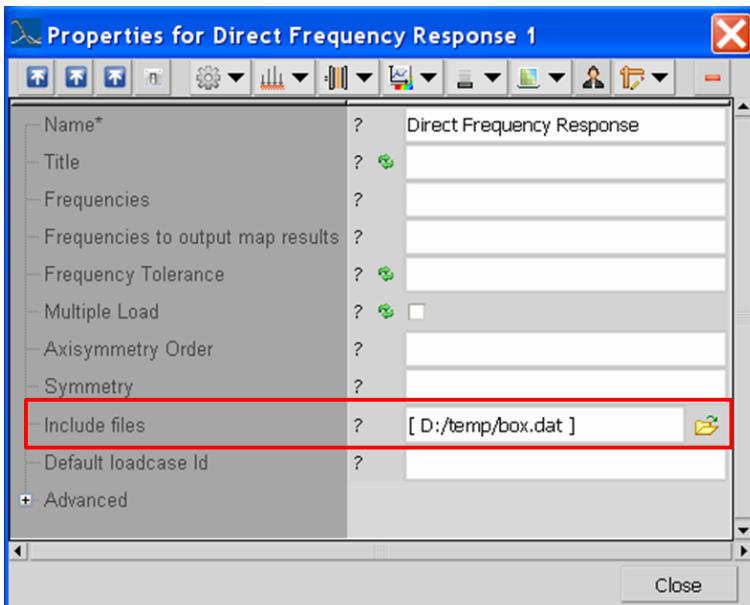

Figure 10.17: File chooser

10.2.6 Shortcut icons

The shortcut icons appear on the top of the property windows (Figure 10.18). These shortcut icons carry the same functions as the functions in the right click menu of a data tree node.

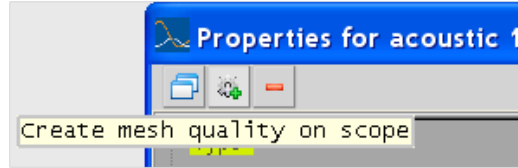

Figure 10.18: Shortcut icons

Placing the mouse on the short icon, a short description of the function appears.

10.2.7 Add and remove a data line sub-entry

In some property windows, multiple entries of a same type can be defined. Figure 10.19 shows these type of entries, indicated by a couple of "+" and "-" signs or simply a "+" sign.

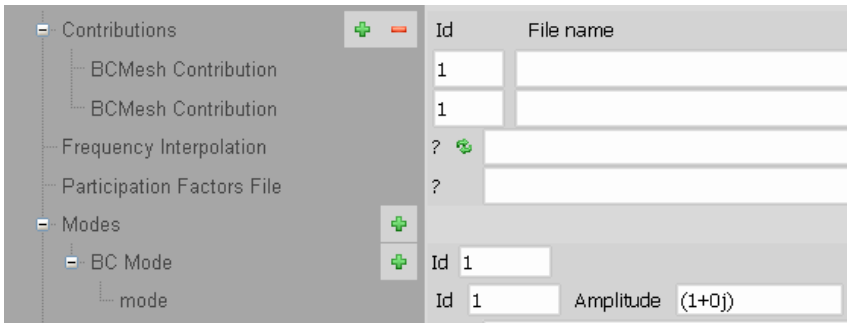

Figure 10.19: Entries relying on sub-entries

In order to add a sub-entry, the user should click on the "+" sign of the primary entre. This is shown in Figure 10.20.

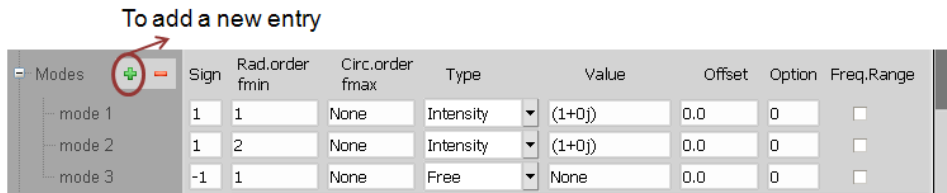

Figure 10.20: Add a sub-entries

In order to remove a sub-entry, the user should first select the sub-entry using

mouse left click, and then remove the sub-entry using the "-" sign, as shown in Figure 10.21.

To remove an entry

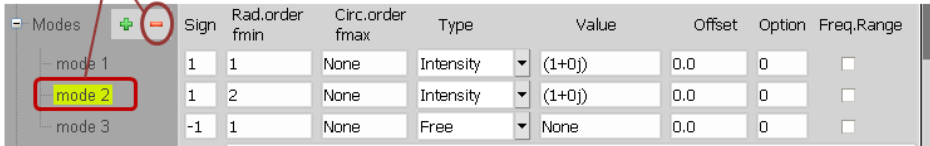

Figure 10.21: Remove a sub-entries using "-" sign

In some properties windows, the "-" sign is not available for removing the entries. In this case, one needs to use the Delete key after selecting the entry, as shown in Figure 10.22.

To remove an entry: Select the entry and press Delete key

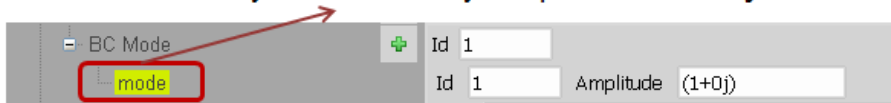

Figure 10.22: Remove a sub-entries using Delete key

10.2.8 Scope Selector

In the data tree panel, to associate a data tree node with another data tree node is a regular operation. Examples of such an operation are: associating a **PID** with a **domain**, or associating a **domain** with a **component**, or in general associating data tree node 1 with data tree node 2. When such an association is done by putting node 1 into the scope of node 2, the scope selector of node 2 can be used to facilitate the association.

The scope selector appears in the property window of a data tree node, as shown in Figure 10.23.

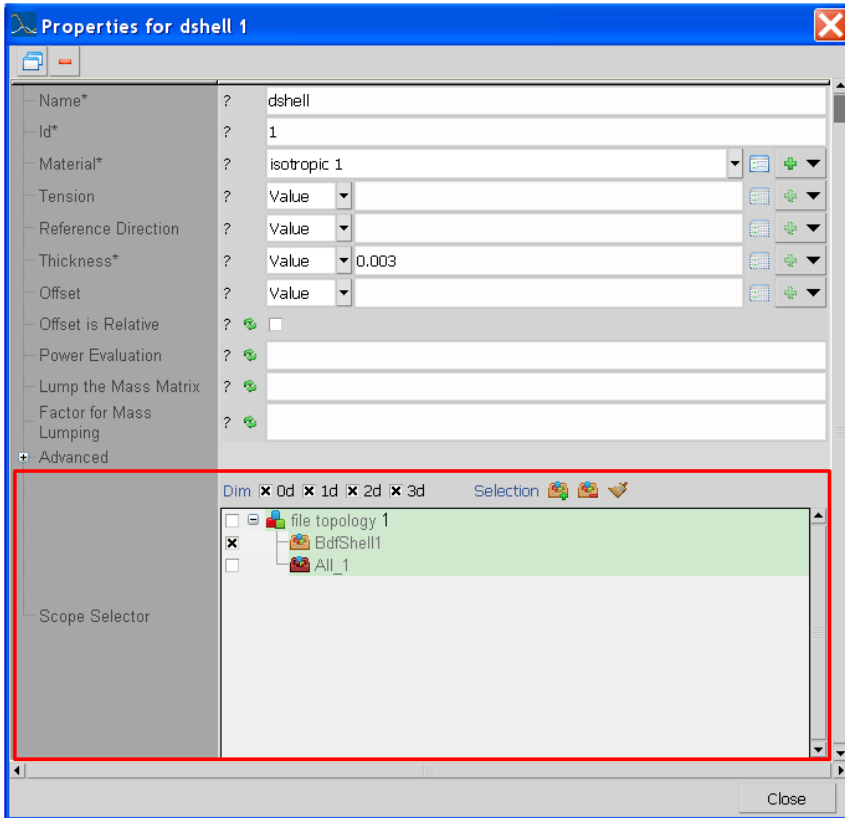

Figure 10.23: A scope selector in the property window of a component

A scope selector contains 4 parts, shown in Figure 10.24. These 4 parts are:

- Available items for the scope: all the entities acceptable by the scope are listed;
- Selection check-box: check-box is used to select the desired items for the scope;
- Dimension filter: visibility filter acting on the dimensions of the listed items in the scope selector;
- Selection tools: the selection tools help to select/unselect one or multiple items. During the selection, one can use the left mouse button and the Ctrl key to choose multiple items in the scope selector. This is explained in Figure 10.25.

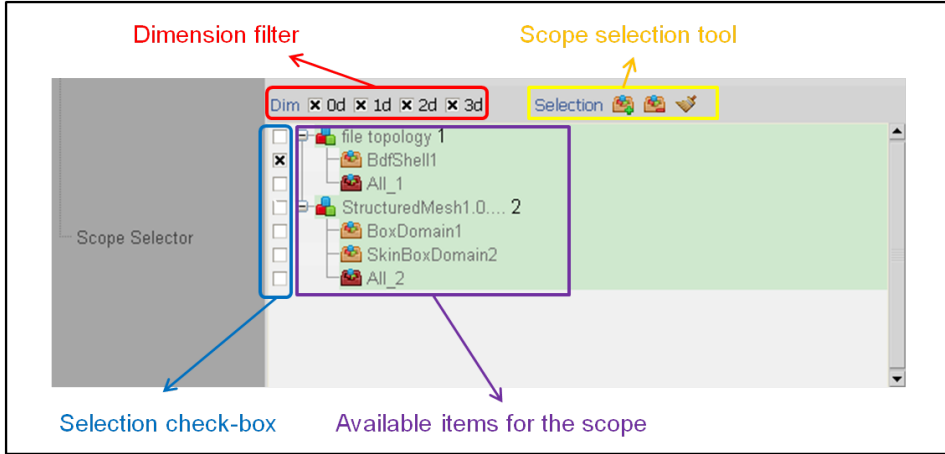

Figure 10.24: Four parts in a scope selector

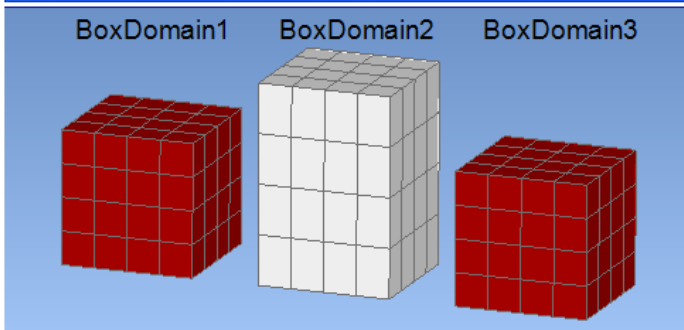
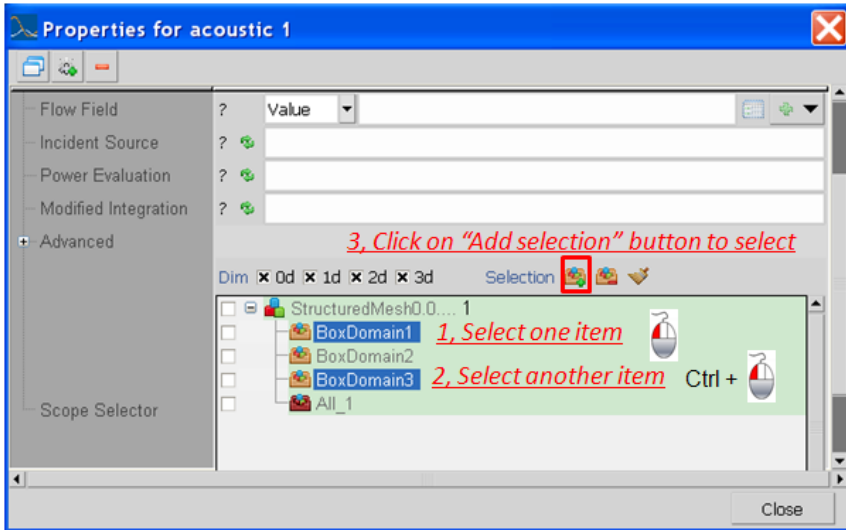

Figure 10.25: Selection tools of a scope selector

The selection in the scope selector of a data tree node is always synchronized with the content in the scope of that node. This is shown in Figure 10.26.

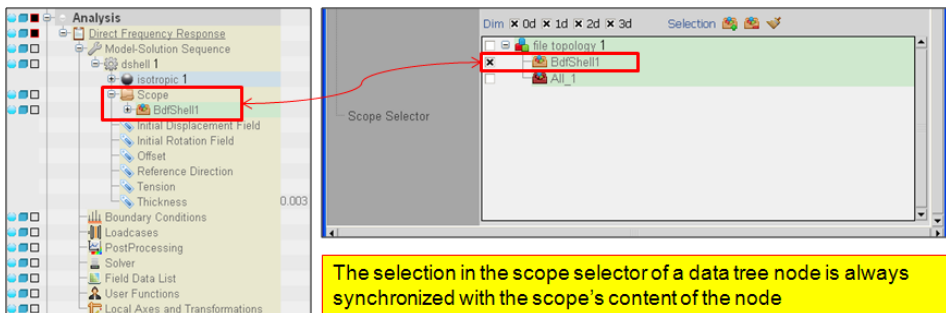

Figure 10.26: Synchronization between the scope selector and the scope

10.2.9 Remarks and Further Reading

- When a [data tree node](#) is created, its property window is popped-up.

10.3 Topologies Tree

The Topologies tree is a container of all the topologies imported and/or created in ACTRANVI. A topology contains:

- Information of the finite elements mesh;
- Information of the ACTRAN [Domains](#).

10.3.1 Topology import

In ACTRANVI, the user can import an external mesh file, an ACTRAN .dat file or an ACTRAN .edat file. The import can be done through the [menu](#).

File → Import mesh ... → format

As the selected file is imported, the user can choose to load (or not) the mesh through a popup window (Figure 10.27) and options related to the format.

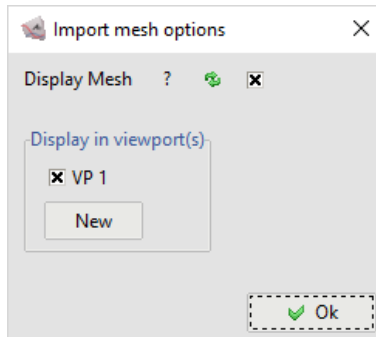

Figure 10.27: Popup window for loading the mesh information

When the mesh is imported, it appears in ACTRANVI as a topology.

If the mesh is not loaded, only the reference to the imported mesh file is shown in the [topology property](#). The mesh is not displayed under the topology, nor in the [render window](#). In order to load the mesh, the user can use the right click menu of the topology and select "Load", as shown in Figure 10.28.

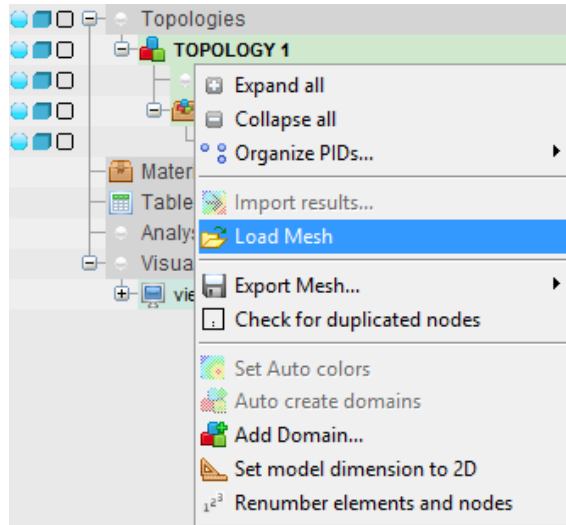

Figure 10.28: Load mesh of a topology

If the "Display mesh" option is selected at topology import. The full mesh information is loaded in the topology. This is shown in Figure 10.29.

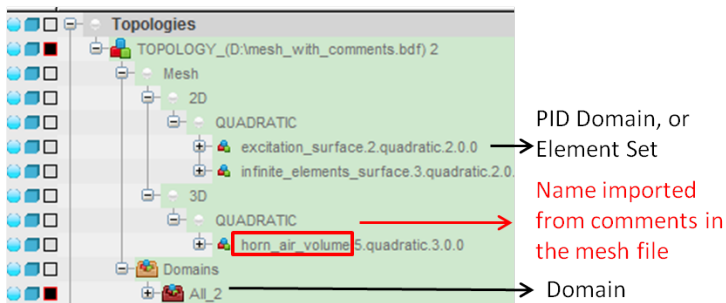

Figure 10.29: A topology in the data tree

As shown in Figure 10.29, a Topology has a Mesh node and a Domains node. The different entities of the mesh are grouped together according to their PID. The names of the PID Domain's can be read from comments in a BDF mesh file or a CDB mesh file depending on the meshing tools used to generate the files.

10.3.2 Creating topology

Some types of topologies can also be directly created in ACTRANVI. A new topology can be creating when using the [Meshing tools](#) or when [field points](#) are

created (Section 13.3.5).

10.3.3 PID domain

The PID domains (or simply PID's) appear in the Mesh node of a Topology. When a topology is imported from a mesh file (BDF file, CDB file, or UNV file, etc.), the PID's are automatically generated. A distinct PID is created for each distinguishable part of the mesh, for example by "Property" in a .bdf file, or by an "Element type" in a .cdb file.

Each PID has three attributes:

- Dimension: 0D, 1D, 2D or 3D;
- Interpolation order: linear or quadratic;
- PID number: alphanumerical characters.

The dimension and the PID number attributes cannot be modified. The interpolation order can be modified using the [re-interpolation](#) function.

According to the three attributes, the PID's can be organized in several ways. The default organization method is to group the PID's, first, based on their dimensions, secondly, based on their interpolation level and finally based on their PID numbers. Other organizations method can be selected using the right click menu of the topology and choose Organize PIDs. This is shown in Figure 10.30.

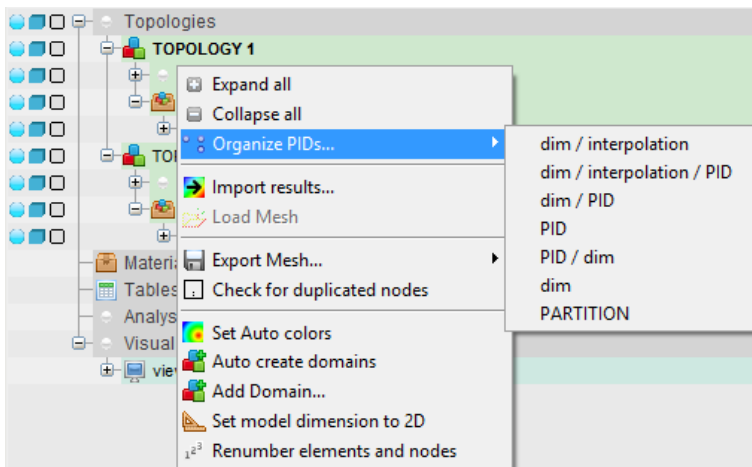

Figure 10.30: Different options for organizing the PID's

A PID can be removed using the right click menu of the PID and the remove function, or using the Delete key.

The "Auto create domain" function in the right click menu of a PID allows creating a [domain](#) that contains this PID.

10.3.4 Domains

The Domains node of a topology is a container of all the domains. A domain contains one or multiple PID's. Figure 10.31 shows a topology with different domains under it.

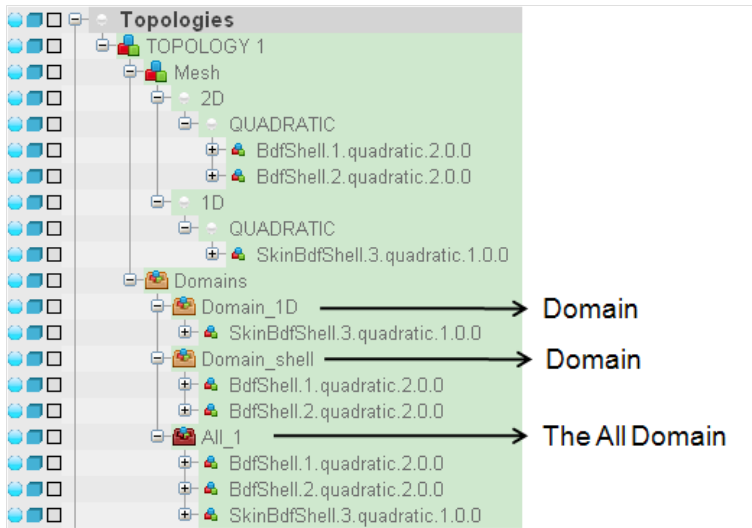

Figure 10.31: Different domains under a topology

In order to place the PID's into a domain, the user can perform a [drag'n'drop](#) of the PID's into the domain, or use the [scope selector](#) of the domain to choose the PID's.

The "Add new domain" function in the right click menu of the Domains node allows for creating a new empty domain.

The "Auto create domains" function in the right click menu of the Topology node allows for creating one domain for each PID in the topology.

An "All" domain is always automatically defined under a topology. This domain takes all the PID's under the mesh node of the topology.

In the [property window](#) of a domain (Figure 10.32), its PID's are shown as selected items in the scope selector. If the domain is used in a [component](#) or in a

boundary condition, the component or the boundary condition is indicated in the "Used in" field.

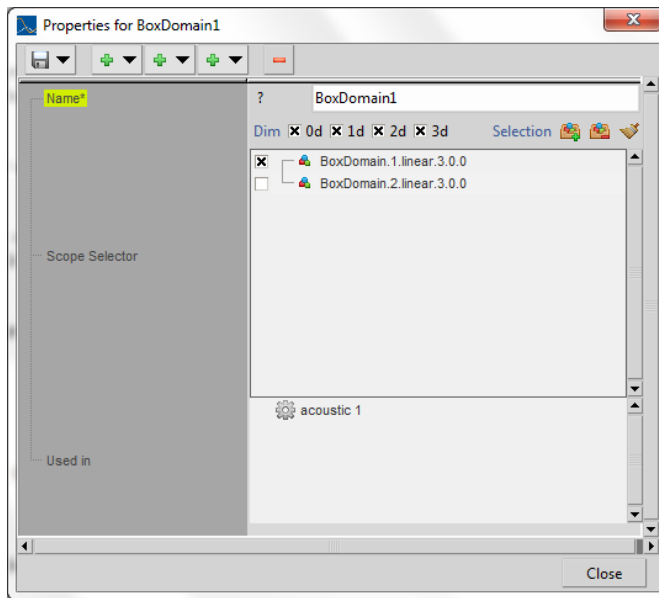

Figure 10.32: Property window of a Domain

10.3.5 Fields and related operations

Each PID includes several fields. At least, it should include coordinate and external node and element numbering. Additional fields can be included by importing results from external result files or when importing an analysis. Fields are characterized by their quantity type (which is referred to from the post-processing), their realisations and their number of components (size of the results, scalar or vector quantities), the number of values and the results interpolation (linear, discontinuous, ...). Fields can be used both in pre-processing, to support spatially-varying quantities or in post-processing to support results and allow mathematical operations between results.

Figure 10.33 shows the different options that can be applied on fields.

- A Field Viewer can be added to the field to edit or post-process the field. This is discussed in the next subsection.
- The field can be duplicated to perform mathematical operations. When duplicating, its size, quantity type or even the default values of the field can be modified. More information can be found in the next subsection.

- The field and its supporting domain can be exported in a dedicated NFF database.
- The field can be removed, except for coordinates or external numbering fields.
- The reference to the field can be copied inside the console, or its content printed inside the console as well.
- The properties of the field, describing its quantity type, number of realisations, components or values and the interpolation type can be accessed.

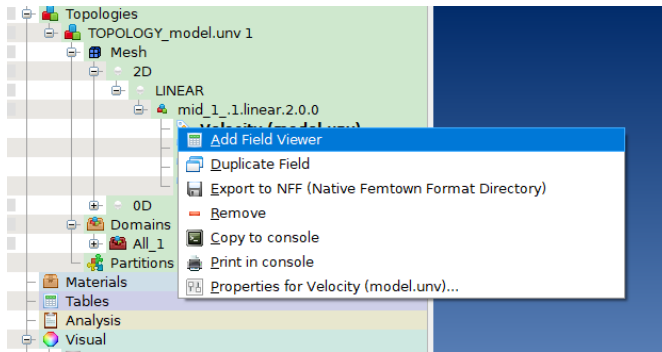

Figure 10.33: Available options for fields

Field duplication

To create new fields for pre- or post-processing, it is usually easier to duplicate an existing field and its related characteristics. For post-processing for instance, a new field can be made to perform mathematical operations (the difference of two existing fields). The duplicate Field option allows to perform such operation, as shown in Figure 10.34. The following options are available:

- The name and the quantity of the new field can be selected. By default, the name of the existing field is chosen, followed by a `_copy`, and the quantity is kept. When the quantity of the original field is `COORDINATE` or `EXTERNAL_NUMBERING`, it is set to `USER_DEFINED`.
- The field properties such as the continuous or discontinuous shape, the interpolation or the value type (integer, real or complex) can be chosen. If the required operation is not valid, the new values will be set to 0.
- A default new Field Value can replace the existing values of the field by the provided constant value. By default, the field values are duplicated.

- The number of components and the number of realizations of the field can be modified. In most cases, the original values will be replaced by 0.
- When a field quantity is present in multiple PIDs (a displacement field imported over a complex structure for instance), the Duplicate All option allows to duplicate all the fields having an identical quantity at once.

The obtained new field can be used for pre- or post-processing purposes. Editing a particular field is then usually performed using the ACTRAN API, in which a direct access to the field quantities is provided using the regular python expression, as shown in Figure 10.35. More information on the API support of the duplicate field can be found in the API documentation.

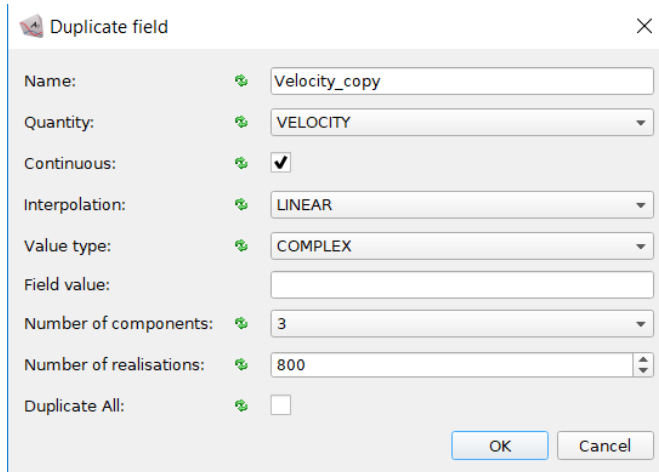

Figure 10.34: Duplicating existing fields

```
>>> [field_1] = actranvi.add_field(field=actranvi.get_field( actranvi.get_pid_domain( topology_2 , pid=1 ) , qu
ntity='PRESSURE' , name='fp (cavity.nff)' ) , name='fp(cavity.nff)_copy' , quantity='PRESSURE' , continuous=True, int
erpolation='quadratic' , num_comp=1 , num_realisations=5)
>>> field_1 = actranvi.get_field( actranvi.get_pid_domain( topology_2 , pid=1 ) , quantity='PRESSURE' , name='f
p (cavity.nff)' )[:, :, :] * 2.0
>>>
```

Figure 10.35: Usage of additional fields for post-processing

Field edition and visualization

To visualize or locally modify a Field, the Field Viewer can be created. It can directly be created on a Field as shown in the Field options in Figure 10.33. The content of the Field Viewer is shown in Figure 10.36.

- The realization (frequency, time and loadcase) of the field can be selected.

- Either all components of the field can be visualized, or only one.
- The Values Histogram allows to visualize the results of a particular component over the selected filtered values, for post-processing only.
- Both nodes or elements ids restrictions or additional filters on values can be added, to visualize a subset of results of interest. For instance, all nodes having a displacement greater than a particular quantity can be visualized.
- Based on the restrictions on both nodes or elements ids and on the filters, the results are shown on the right hand panel. Different of operations can be done on such results:
 - A subset of nodes or elements can be selected by the user, and picked inside the 3D render window to visualize their location.
 - The values can directly be edited inside this window. Multiple entries can be modified at once. When those value changes are to be effective, the save value change button confirms those changes. The Revert value changes allows to come back to the original state.
 - The selected restricted list can easily be saved as a csv file.

Please note all of these options are accessible through API, allowing to automate post-processing and to automatically select or identify particular nodes or elements based on a filter. Also, since fields can directly be accessed through the API, large mathematical operations on fields are usually easier to be performed through scripting. More information can be found in the API documentation.

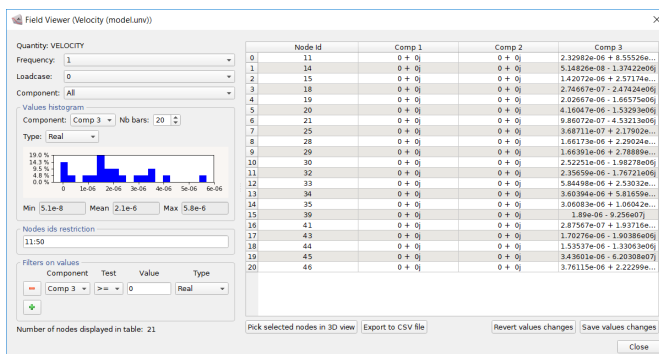

Figure 10.36: Visualization of edition of fields

10.3.6 Properties of a topology

In the [property window](#) of a topology (Figure 10.37), the following properties are available:

- Name: the name of a topology is shown in the topology node;
- ID: this is a numerical ID. A topology should have a unique ID;
- File and Format: if the topology is imported from an external file, these attributes are the file name and the file's format. If the domain is created in VI, these two attributes are None and ACTRAN;
- Model dimension: this attribute informs the user about the number of coordinate dimensions the topology has. The dimension of the topology can be changed by the user through this parameter or by using the dedicated "Set model dimension to" button. The setting of the parameter allows to create meshes for 2D and 2D axi-symmetric models. When the model dimension is changed to 2D from 3D the Z coordinate is discarded.
- Model dimension to force at import: this option can be used to specify the dimension of the topology to be considered at import.
- Length Unit and Mass Unit: the Length Unit is a scale factor applied on the dimension of the topology. The Mass Unit is a scale factor applied on the mass of the topology. For more information, refer to ACTRAN User's Guide, Section 5.6 of Volume 2;
- Mesh tolerance : this option can be used to set the distance tolerance between two points. Below that value, the two points will be considered to be the same (default value is set to 0.0001);

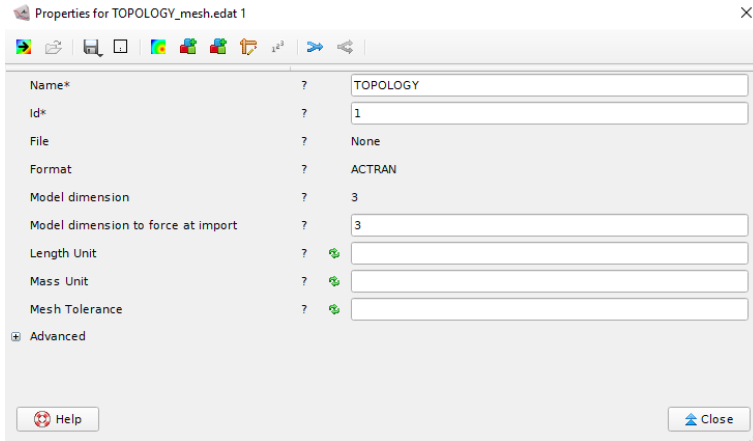

Figure 10.37: Topology property window

10.3.7 Topology export

An entire topology can be exported to a mesh file or to an ACTRAN EDAT file. This is done via the "Export mesh" function located in the right-click menu of the topology.

The following export formats are available for all types of topologies:

- NFF with fields;
- NFF without fields;
- BDF;
- UNV;
- DAT;
- EDAT.

For the export in NFF format, it can be either chosen to export loaded fields with the NFF database (NFF with fields) or to export without fields (NFF without fields).

For the export in EDAT format, different types of the EDAT topology can be proposed:

- If the topology is created by reading a mesh file or by importing a DAT analysis, the topology has the attributes "File" and "Format" in its property window, as shown in Figure 10.37. In this case, the topology can be exported using EDAT explicit format (choose ACTRAN option in the format selection popup, as shown in Figure 10.38), to NFF format (choose NFF option) or as a redirection to an external file (choose FILE option);
- If the topology is created in ACTRANVI, it does not have the "File" attribute. In this case, it can only be exported using EDAT or NFF explicit format;
- If the topology is in BOXPRO format, it can be exported using BOXPRO format (choose BOXPRO option in the format selection popup, as shown in Figure 10.39), to NFF type (choose NFF option) or using EDAT explicit format (choose ACTRAN option).

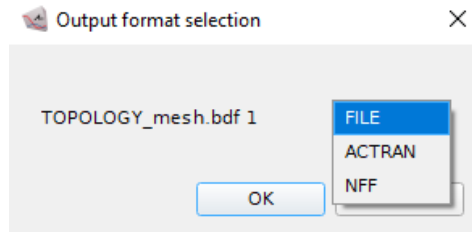

Figure 10.38: Topology output format selection - FILE, ACTRAN, NFF

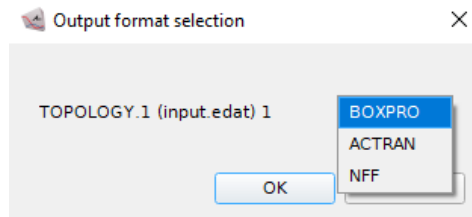

Figure 10.39: Topology output format selection - BOXPRO, ACTRAN, NFF

For more information about the different formats of EDAT please refer to ACTRAN User's Guide, Section 5.6 of Volume 2.

10.3.8 Auto Color Feature

The Auto Color feature allows automatically coloring the different **PID domains** contained in a topology. This feature is accessed by right-clicking on the topology (Figure 10.40).

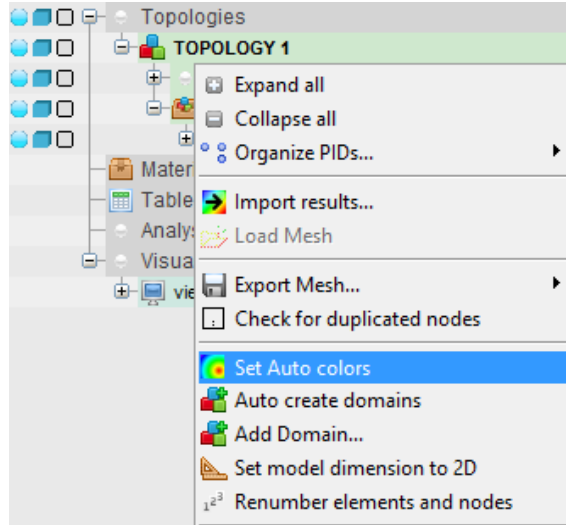

Figure 10.40: Set auto colors

10.3.9 Modify dimension

If a topology is assumed to be 2D, this can be directly set through the right-clicking menu on the topology (Figure 10.40).

10.3.10 Renumber elements and nodes

When performing many mesh operations on a particular model, the identification number of nodes and elements can become quite important. In order to compress these, a renumbering option is accessible through the right-clicking menu on the topology (Figure 10.40).

10.3.11 Re-interpolation

The re-interpolation function can be accessed in the right click menu of a topology. Linear mesh can be converted to quadratic and vice-versa.

10.3.12 BOXPRO Topology

In ACTRANVI, a BOXPRO topology can be imported, created, edited and exported. The syntax of the BOXPRO topology can be found in the ACTRAN User's Guide, Section 5.6 of Volume 2.

A BOXPRO topology contained in an ACTRAN input file (EDAT format) can be imported into ACTRANVI through the [menu](#):

File → Import mesh ... → EDAT

In order to create a new BOXPRO topology in ACTRANVI, right-click on the Topologies node and select "Create new BOXPRO topology...". (shown in Figure 10.41).

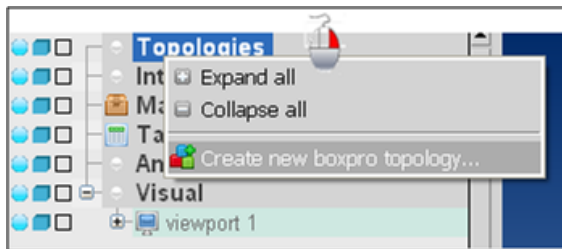

Figure 10.41: Create a BOXPRO topology in ACTRANVI: 1, Creating the topology node

When a BOXPRO topology is created, one needs to edit the Graduation X, Y and Z in the [property window](#). These graduations values define the limits and the mesh refinements of the BOXPRO topology. They correspond to the BEGIN X, BEGIN Y and BEGIN Z data blocks in the BOXPRO topology described in the ACTRAN User's Guide, Section 5.6 of Volume 2.

For example, Figure 10.42 defines a BOXPRO topology that covers a X range from 0 to 10, with an element size of 1; a Y range from -5.5 to 5.5, with an element size of 0.1; a Z range from 0 to 10, with an element size of 2.

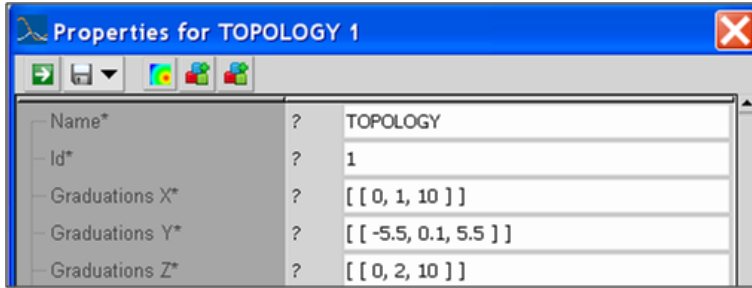

Figure 10.42: Create a BOXPRO topology in ACTRANVI: 2, Edit the graduations

Once the graduations are defined, the user can create the BOXPRO domains, through the "Add new domain" in right click menu of the Domains node.

Figure 10.43 shows the creation of a 3D linear domain. The domain is created based on logical operation (add - remove) of one or several cubic regions. When a region is "added" (region 1 in the example), the related elements (defined based on the graduations) are allocated to that domain. When a region is "removed" (region 2 in the example), the related elements are taken out of the domain.

The Range X, Y and Z define the 3 ranges of the region. If the range of a dimension is left empty, the region takes the entire range defined in the graduation of that dimension of the BOXPRO topology. If the range does not fall on the exact elements positions defined by the graduations (in the example, Range Y of region 1: -0.3 , 0.21), the elements generated will be those completely included in the defined range.

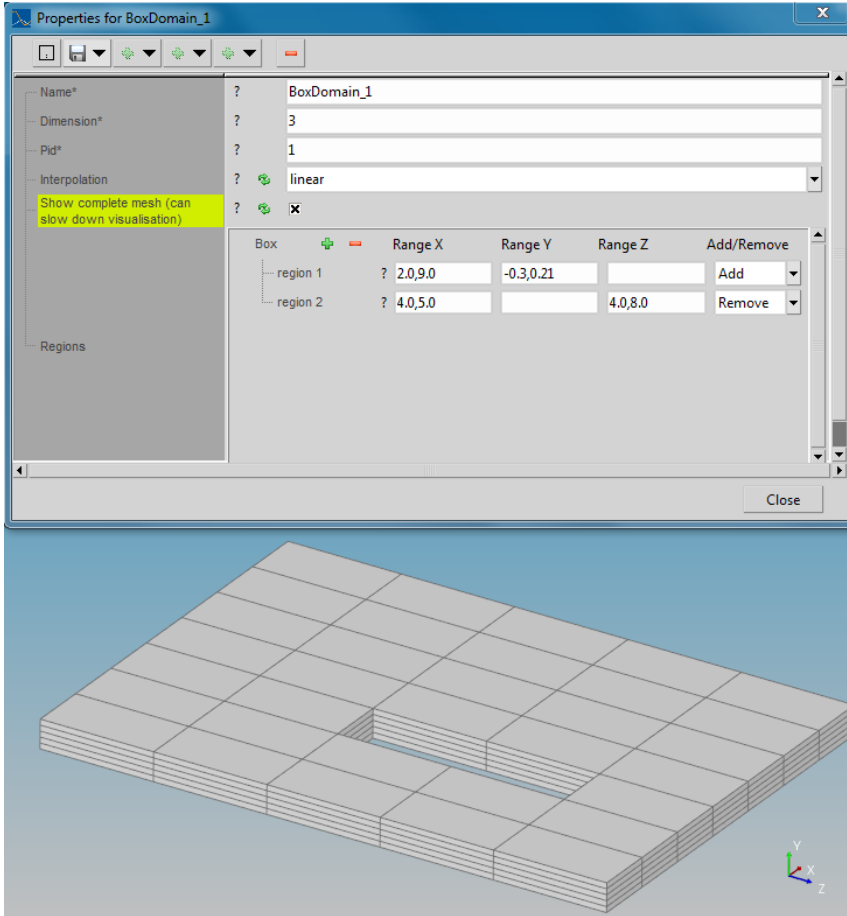

Figure 10.43: Create a BOXPRO topology in ACTRANVI: 3, Add a 3D domain

Figure 10.44, Figure 10.45 and Figure 10.46 show the examples of adding a 2D domain, 1D domain and 0D domain, respectively.

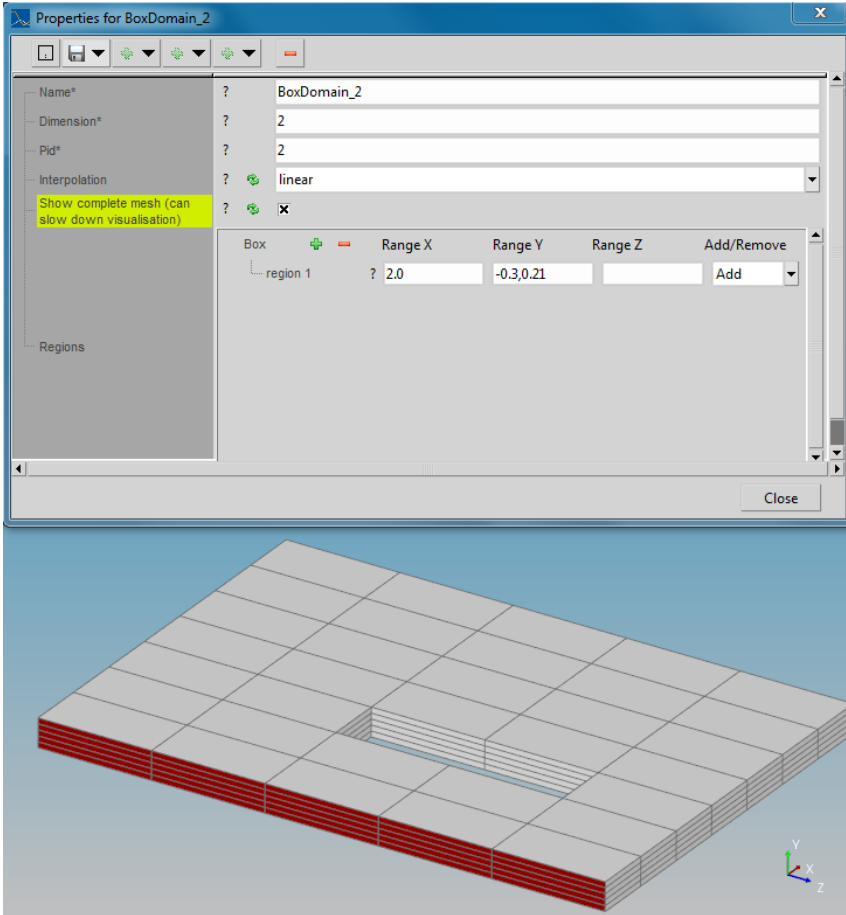

Figure 10.44: Create a BOXPRO topology in ACTRANVI: 4, Add a 2D domain

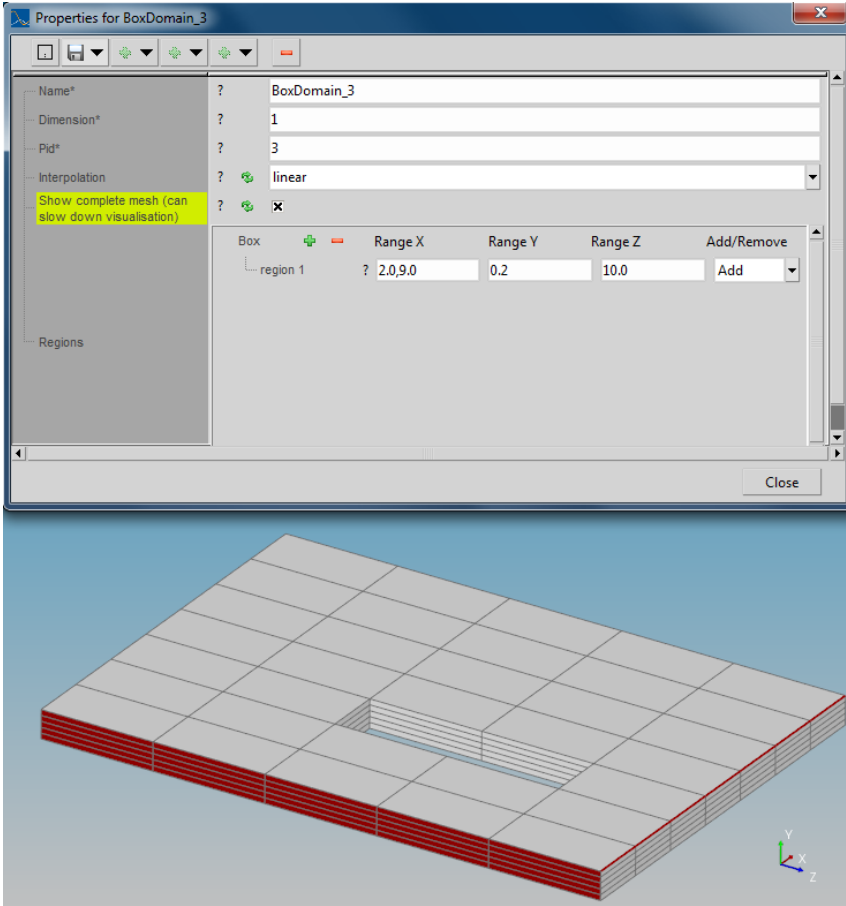

Figure 10.45: Create a BOXPRO topology in ACTRANVI: 5, Add a 1D domain

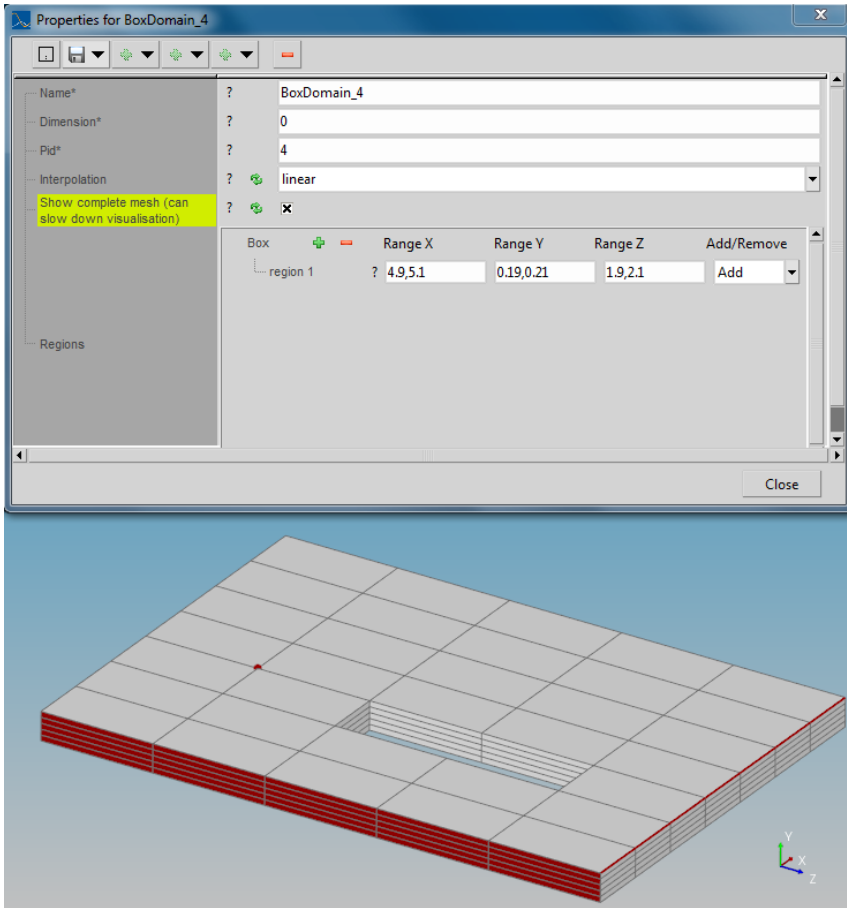

Figure 10.46: Create a BOXPRO topology in ACTRANVI: 4, Add a 0D domain

In the property window of a BOXPRO domain, the different entries are explained below:

- Dimension: indicating the dimension of the BOXPRO domain;
- PID: if the BOXPRO domain is exported to a mesh, the domain will have this ID number;
- Interpolation: the interpolation order of the domain, linear or quadratic;
- "Show complete Mesh" check-box: construction and display of the finite element mesh. Otherwise, a box-like geometry defined by all regions is displayed.

A BOXPRO topology can be exported through the [export topology](#) operation. If the EDAT format is selected for the export, the user can further select either the BOXPRO format or the ACTRAN format. With the BOXPRO format, the finite element mesh is not explicitly exported; in the ACTRAN format, the finite element mesh is created and exported in the input file.

Refer to the ACTRAN User's Guide Section [5.6](#) of Volume 2 for more description on the syntax of BOXPRO topology.

10.4 Materials

In the Materials tree, the different types of valid ACTRAN materials can be created, imported and exported.

10.4.1 Create a material

The "Add new Material" function can be accessed through right-click of the Materials node.

Figure 10.47 shows the list of materials available in ACTRAN.



Figure 10.47: Materials available in ACTRAN

When a material is created, its [property window](#) pops up.

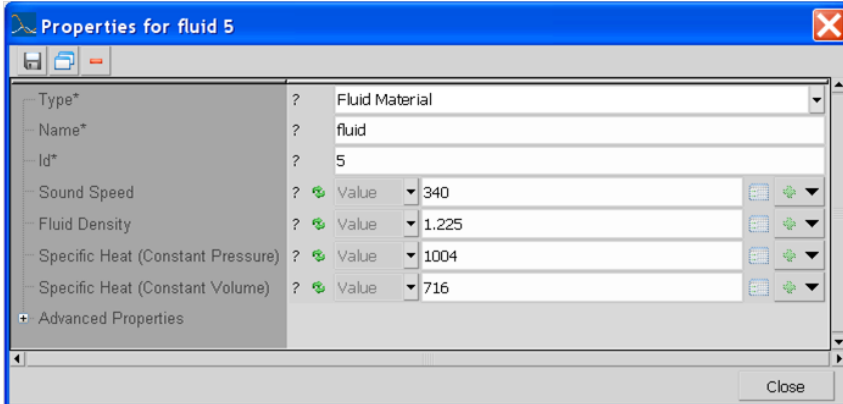

Figure 10.48: Property window of the Fluid material

Some entries in the material's property window support both definition by Value and definition by Field (refer to section [Value/Field](#)). The definition by Field can be activated only when an analysis is created.

10.4.2 Import a material

The "Import Material" function can be accessed through right-click menu on the Materials node. In particular a material can be imported from a library of pre-defined materials located in the ACTRAN installation folder.

10.4.3 Export a material

A material can also be exported to a text file. This is done through right-click on the material, as shown in [Figure 10.49](#).

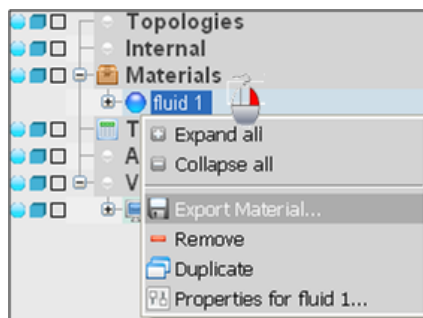

Figure 10.49: Export a material

Click [here](#) to see a video example.

10.4.4 Available ACTRAN materials

The following types of material are available in ACTRAN

- Fluid: refer to ACTRAN User's Guide, Section 7.8 of Volume 2;
- Perfect gas: refer to ACTRAN User's Guide, Section 7.16 of Volume 2;
- Water: refer to ACTRAN User's Guide, Section 7.26 of Volume 2;
- Isotropic solid (Young-Poisson, Lame): refer to ACTRAN User's Guide, Section 7.9 of Volume 2;
- Transverse isotropic: refer to ACTRAN User's Guide, Section 7.24 of Volume 2;
- Orthotropic: refer to ACTRAN User's Guide, Section 7.15 of Volume 2;
- Poroelastic (Young-Poisson, Lame): refer to ACTRAN User's Guide, Section 7.18 of Volume 2;
- Beam: refer to ACTRAN User's Guide, Section 7.4 of Volume 2;
- Stringer: refer to ACTRAN User's Guide, Section 7.22 of Volume 2;
- Spring: refer to ACTRAN User's Guide, Section 7.21 of Volume 2 ;
- Composite solid (External properties, Layers): refer to ACTRAN User's Guide, Section 7.5 of Volume 2;
- Sheet: refer to ACTRAN User's Guide, Section 7.20 of Volume 2;
- External properties: refer to ACTRAN User's Guide, Section 7.27 of Volume 2.
- Perforation : refer to ACTRAN User's Guide, Section 7.17 of Volume 2;
- Voice Coil : refer to ACTRAN User's Guide, Section 7.25 of Volume 2;
- Piezoelectric Tetragonal : refer to ACTRAN User's Guide,Section 7.23 of Volume 2 ;
- Piezoelectric Orthorombic : refer to ACTRAN User's Guide,Section ?? of Volume 2 ;
- Piezoelectric Anisotropic : refer to ACTRAN User's Guide,Section 7.2 of Volume 2

10.4.5 Remarks and Further Reading

- In the [Settings](#), the user can backup the material library data. This operation is useful when upgrading to a new revision of ACTRAN.

10.5 Tables

In ACTRAN TABLES are used to define the frequency or time dependent quantities.

10.5.1 Import a Table

A TABLE written in the text file can be imported into ACTRANVI, through the right-click menu of the Tables node, as shown in Figure 10.50.

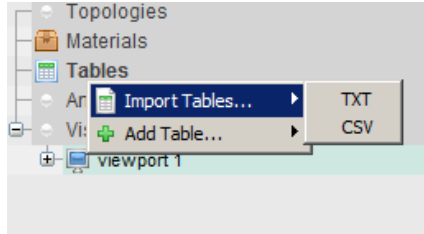

Figure 10.50: Import a Table

Two types of table syntax are supported:

- TXT format: Includes direct TABLE data blocks inside an ACTRAN format or a simple text format (UTF-8). For a TABLE format, only a single table can be specified per file, but can contain multiple columns at once. Below is an example:

```
BEGIN TABLE 1
NAME My_table
3 2
110 1 3 5
120 2 4 6
END TABLE 1
```

Using standard text format, multiple columns can be added as well. The syntax for complex numbers in this case can be similar to standard ACTRAN convention or Python convention $1 + 2.5e5$, but cannot be mixed.

```
110 1 3 {0,5} 7 {0,9}
120 2 4 {0,6} 8 {0,10}
```

For both formats, two import modes are possible at import, and can be selected before selecting the external file, as shown in Image 10.51:

- Single column mode directly interprets the real or complex quantity and provide this as a single table entry;
- Double columns mode generates complex numbers based on the real part of two following columns.

On the provided text example, 5 tables are generated using the single import mode:

TABLE 1	TABLE 2	TABLE 3	TABLE 4	TABLE 5
110 1+0j	110 3+0j	110 0+5j	110 0+5j	110 0+9j
120 2+0j	120 4+0j	120 0+6j	120 0+6j	120 0+10j

While 3 tables are generated using the double columns mode;

TABLE 1	TABLE 2	TABLE 3
110 1+3j	110 0+7j	110 0+0j
120 2+4j	120 0+8j	120 0+0j

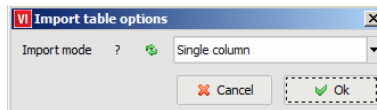

Figure 10.51: Select the import mode of the table

- CSV format: This column formatted format can be imported from any other software. Columns are separated by either commas or semicolons. No complex numbers can be entered as is. To interpret complex numbers, the double columns mode must be used.

10.5.2 Create a Table

In ACTRANVI, a Table can be created through right-click on the Tables node, as shown in Figure 10.52. The Table can be edited in its property window, as shown in Figure 10.53.

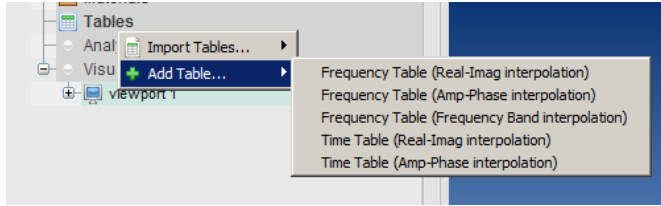

Figure 10.52: Create a Table

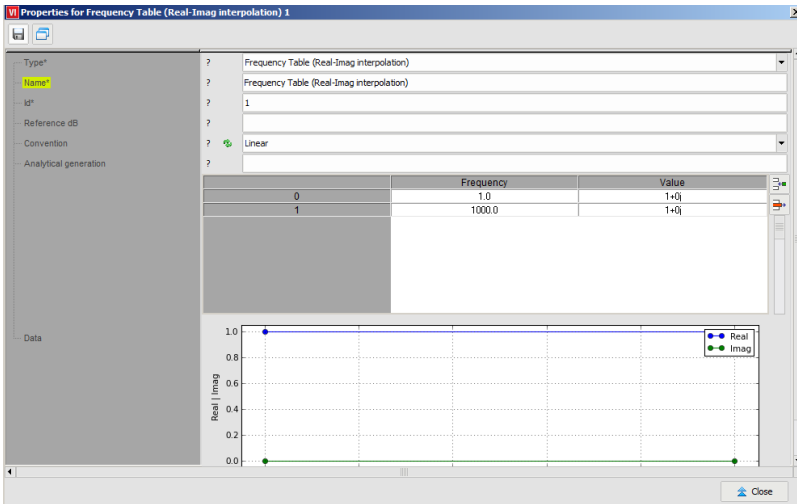

Figure 10.53: Edit a Table

Multiple lines can be added or removed from a particular table, as well as edited. A graphical support for the table is provided within the property window. Depending on the type of interpolation (real-imaginary or amplitude phase), the visualization of the table is adapted.

In addition, an analytical formulation can be specified for a table. By specifying the analytical generation of the function in which either the frequency or time corresponds to x , the table will be automatically filled for each computational frequency or time.

The values already present in the table can also be referenced, by y . This will overwrite the existing values.

10.5.3 Refer to a Table in an analysis

Figure 10.54 shows a Table (ID 1) referred by a fluid material. In practice, a table can be referred to by either entering the TABLE 1 entry, or select a Table option

and enter 1.

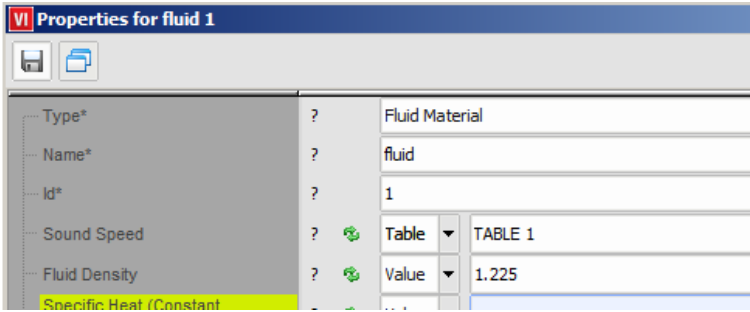

Figure 10.54: Table referred by a fluid material

10.6 ACTRAN Analysis

The Analysis tree is a container for all the parameters of ACTRAN analysis.

Within the ACTRAN preference of ACTRANVI, several types of analyses are available. They are:

- Direct frequency response;
- Modal frequency response;
- Time domain analysis;
- Green analysis;
- Pellicular analysis;
- Modal extraction;
- Compressible flow analysis;
- Incompressible flow analysis;
- Map flow analysis;
- External matrices analysis;
- EA analysis
- VSEA analysis

For the definition of these types of analysis, refer to ACTRAN User's Guide Chapter 5 of Volume 1.

For ACTRAN DGM the types of analysis are different, but the principles are the same.

Three types of [utility analyses](#) are also available in ACTRAN. More information related to these utility analyses can be found in Section [10.7](#).

Figure [10.55](#) shows a Direct frequency analysis under the Analysis node in ACTRANVI.

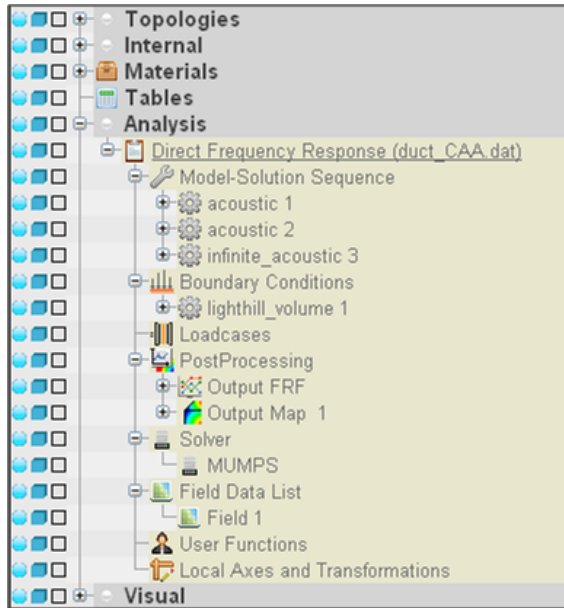

Figure 10.55: A Direct frequency analysis

10.6.1 Analysis import

An ACTRAN analysis can be imported from an analysis input file, through the "File" Menu, shown in Figure 10.56.

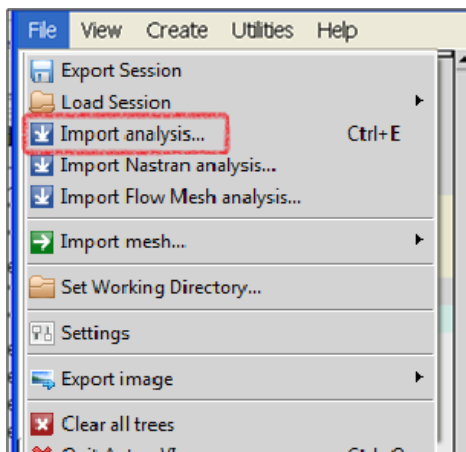

Figure 10.56: Import an analysis through the "File" Menu

10.6.2 Creating an analysis

An analysis can be created via the right-click menu of the Analysis node, as shown in Figure 10.57.

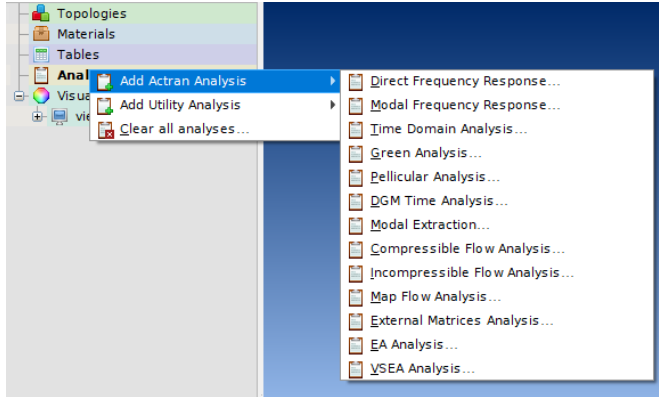

Figure 10.57: Create an analysis

An analysis can also be created from the "File" Menu:

Create → Analysis → Choose analysis type

Click [here](#) to see a video example.

10.6.3 Analysis export

An analysis can be exported using the ACTRAN DAT or EDAT file format. The export function can be accessed in the right-click menu of the analysis. If the analysis is exported to EDAT file, the topologies used in the analysis can be exported to different EDAT topology types:

- If the topology is created by reading a mesh file or by importing a DAT analysis, the topology has the attributes "File" and "Format" in its property window, as shown in Figure 10.37. In this case, this topology can be exported to EDAT explicit type (choose ACTRAN option in the format selection popup, as shown in Figure 10.59), to NFF type (choose NFF option) or to external file type (choose FILE option);
- If the topology is created in ACTRANVI, it does not have the "File" attribute. In this case, it can only be exported to EDAT or NFF explicit type;

- If the topology is in BOXPRO format, it can be exported to EDAT BOXPRO type (choose BOXPRO option in the format selection popup, as shown in Figure 10.60), to NFF type (choose NFF option) or to explicit type (choose ACTRAN option).

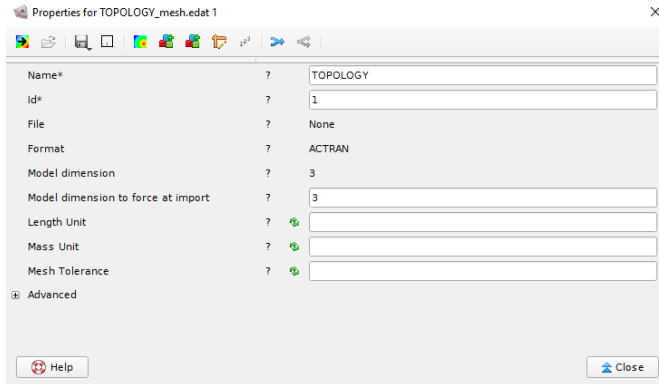

Figure 10.58: Topology property window

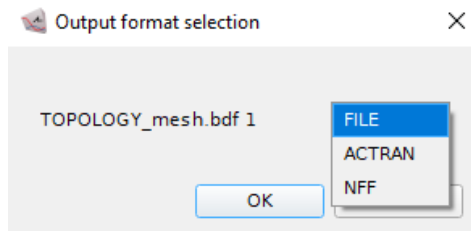

Figure 10.59: Topology output format selection - FILE, ACTRAN, NFF

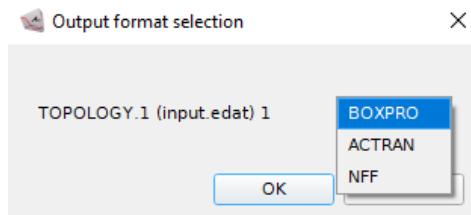

Figure 10.60: Topology output format selection - BOXPRO, ACTRAN, NFF

For more information on the different formats of EDAT please refer to ACTRAN User's Guide, Section 5.6 of Volume 2.

10.6.4 Active analysis

An analysis can be set as the active analysis. If only one analysis is available in the analysis tree, this analysis is active by default. There can be only one active analysis. An analysis must be set to active state before performing the following operations:

- Create components, BC's using the right-click menu of a [Domain](#);
- Create [field point](#) and [field mesh](#) from the [Toolbox](#);
- Validate.

The components, BC's, field points created using the above methods will appear in the active analysis.

To set an analysis to active, right-click on the analysis and choose "Set as active", as shown Figure 10.61.

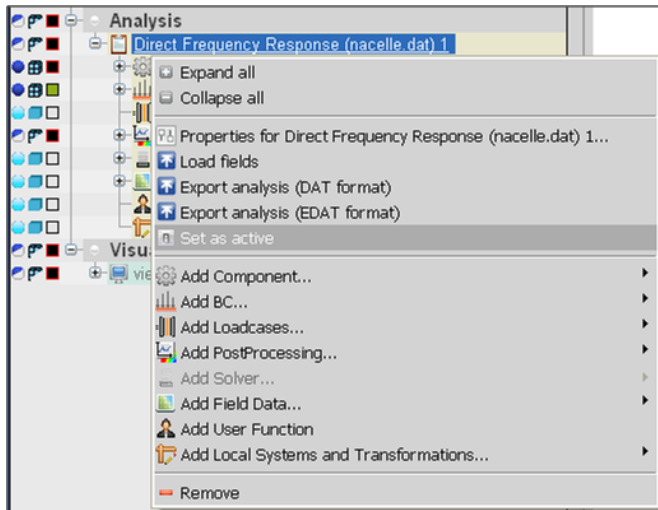

Figure 10.61: Set an analysis as active analysis

10.6.5 Load fields on an analysis

Fields are used in ACTRAN to define space dependent numerical values. Figure 10.62 shows an example where the mean flow on the finite elements is defined using a field.

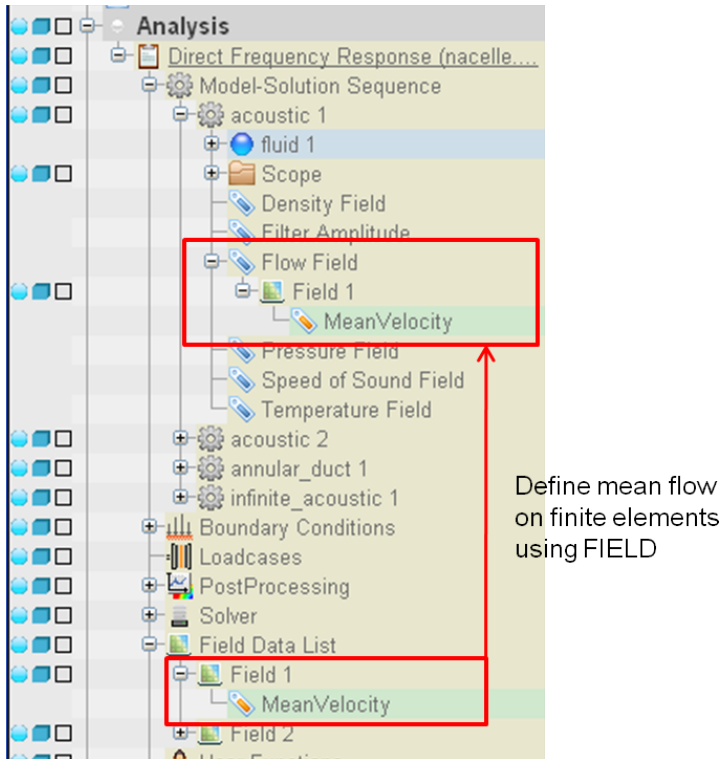

Figure 10.62: Space dependent value defined using field

When an Analysis is imported, if the "Display mesh" option has been selected (refer to Section 10.3.1), all the FIELDS (refer to ACTRAN User's Guide, Section 11.9 of Volume 2) are automatically imported.

One can also load the FIELDS manually by the right-click menu of the Analysis., as shown in Figure 10.63.

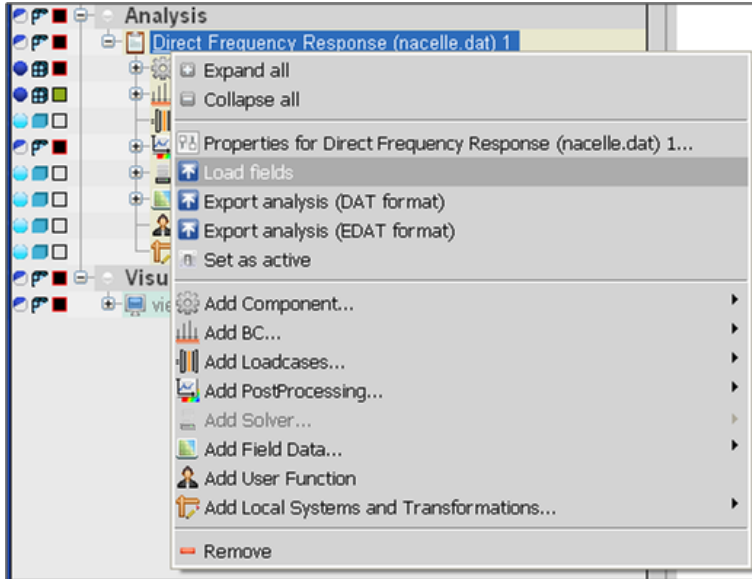

Figure 10.63: Load the Fields in the Analysis manually

10.6.6 Create/Edit Components

Components can be created via:

- the right-click menu of the Model Solution Sequence node;
- the right-click of the related Analysis;
- the shortcut icon in the property window of the Analysis.

A typical component is edited in three steps:

- Select a [material](#);
- Edit the properties;
- Select the [Domain\(s\)](#) using the [scope selector](#).

The above process is illustrated in Figure [10.64](#).

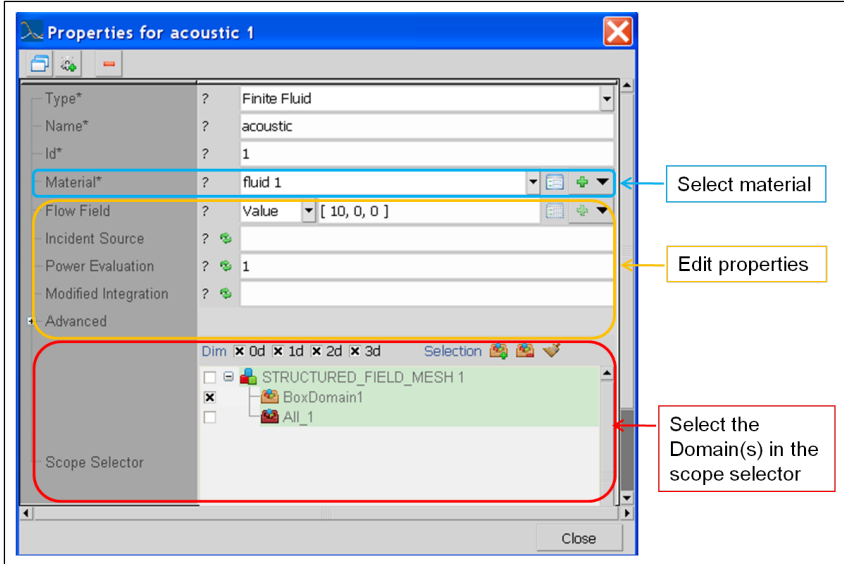

Figure 10.64: Editing a typical component

The modal duct component has one specific feature allowing the automatic detection of the geometric properties defining the duct. In the property window (see Figure 10.65), four buttons can be used one after another. It is important to push the buttons in the right order (from left to right) after having selected the relevant domain in the scope selector. The three first buttons are used to define the parameters whereas the last button can be used to reverse the direction of the modal basis.

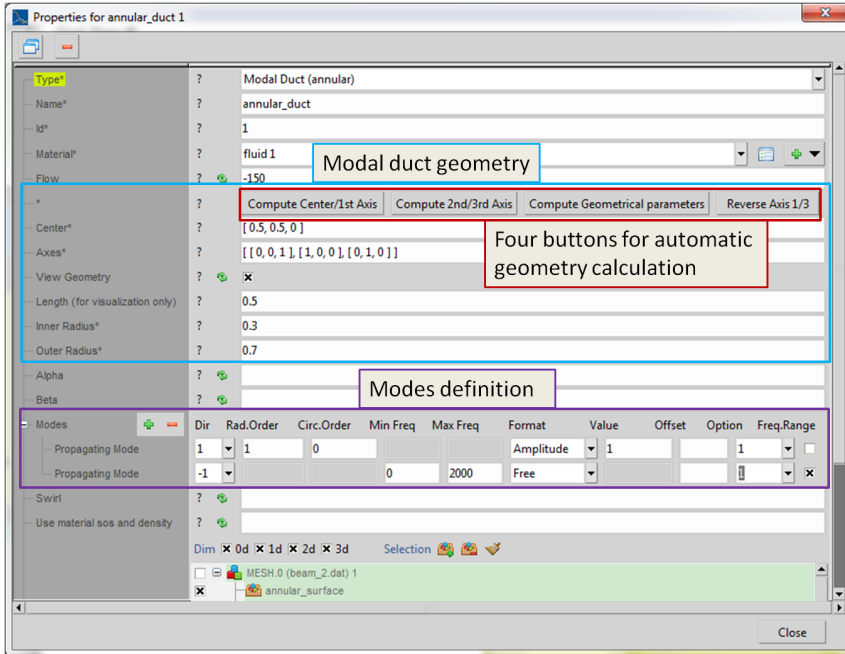

Figure 10.65: Property window of modal duct

The following types of components have special visualization properties:

- Finite fluid in all frequency response analysis. A field representing the local number of elements per wavelength can be created in order to check the quality of the mesh. This can be done via the right-click menu of the Finite fluid component (Figure 10.66). This field takes into account the local refinement of the mesh (longest edge of each element), the local value of the speed of sound including flow effect (the direction of the flow if a velocity field is present), the maximal frequency used during the analysis and the properties of the fluid. In order to produce this result, the user needs to:
 1. Select a valid fluid material in the component;
 2. Select a valid domain in the scope of the component;
 3. Define a valid frequency range in the property window of the analysis.

Figure 10.67 shows the result of mesh quality (right map) in presence of a mean flow (left map). In the presence of a mean flow, the local mach number and recomputed static speed of sound can also be visualized.

- Infinite fluid: the infinite domain is represented by an ellipsoid. This ellipsoid can be visualized in the [render window](#). This is illustrated by

Figure 10.68. If the infinite domain is covering a semi-infinite medium, a particular semi-infinite representation is also shown indicating the far field baffled corresponding to the domain.

- Beam component: for a beam component, the user can visualize its local coordinate system, its offset of center of gravity and its shear offset. The equivalent rectangular beam profile, calculated from its cross section inertia values, can also be visualized. The different visualizations can be turned on in the property window of the Beam component (Figure 10.69). The arrows representing the local system and the equivalent rectangular beam profile are shown on the beam elements in the [render window](#) (Figure 10.70). The center of gravity offset and the shear offset are shown in Figure 10.71;
- Modal duct: In the [property window](#) of the modal duct component (Figure 10.65), one can configure the geometry and the modes of the modal duct. By activating the "view geometry" flag, the geometry of the duct is shown in the [render window](#), illustrated in Figure 10.72.

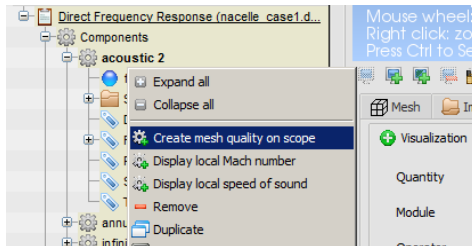

Figure 10.66: Create mesh quality for acoustic mesh

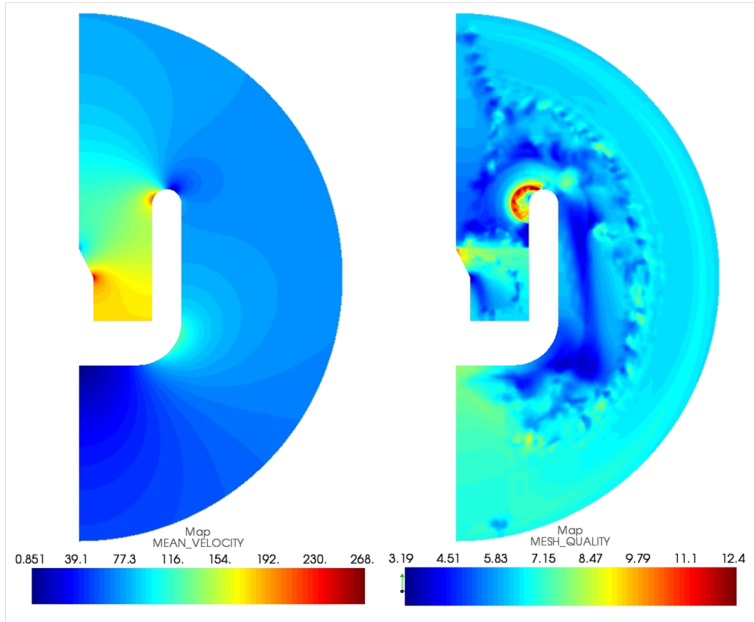

Figure 10.67: Mean flow - Mesh quality

Properties for infinite_acoustic 2

Type*	Infinite Fluid
Name*	infinite_acoustic
Id*	2
Material*	fluid 1
Interpolation Order*	5
Center*	[0, 0, 0.5]
Axes*	[[1, 0, 0], [0, 1, 0], [0, 0, 1]]
Mean Axial Flow	
View Geometry	
Power Evaluation	
Incident Source	

Scope Selector

- MESH.0 (C:\Documents and Settings\ZZ\Desktop\DirectFreque...
- AccelerationBC1
- FiniteDomain1
- InfiniteDomain2
- All_1
- FIELD_POINT.0 (C:\Documents and Settings\ZZ\Desktop\Direc...

Ellipsoid

```
BEGIN COMPONENT 2
INFINITE_DOMAIN
COORDINATE_SYSTEM
0.0 0.0 0.5
1.0 0.0 0.0
0.0 1.0 0.0
0.0 0.0 1.0
ORDER 5
END COMPONENT 2
```

Input file syntax

Figure 10.68: Ellipsoid representing the Infinite fluid domain

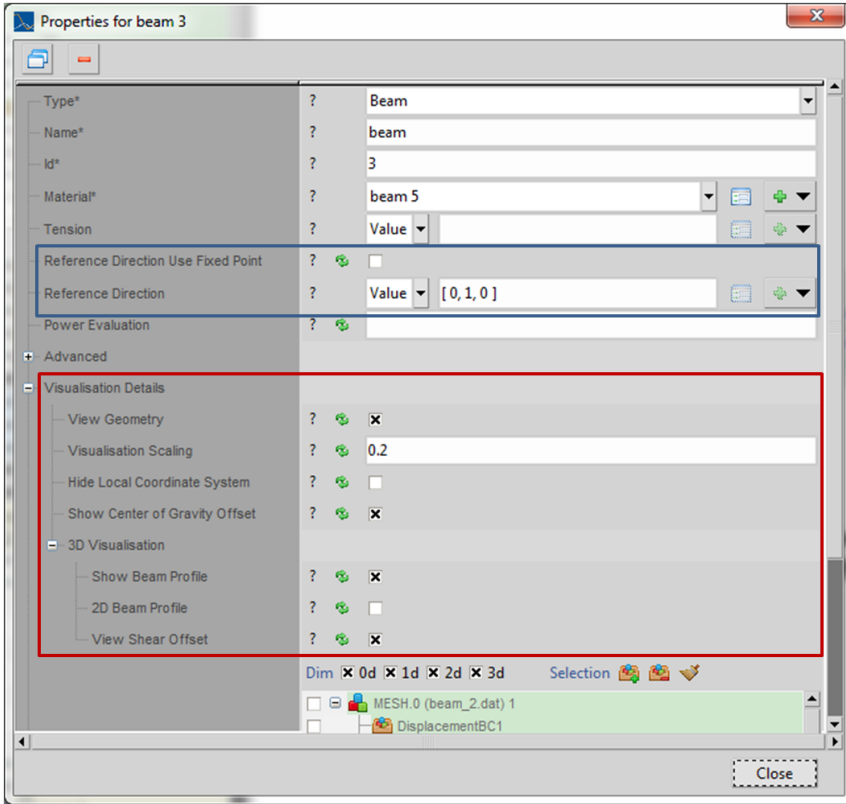

Figure 10.69: Property window of Beam component: visualization

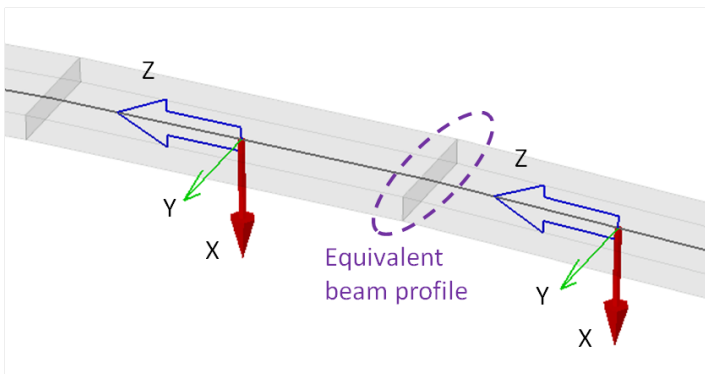

Figure 10.70: Beam visualization: local system and equivalent rectangular beam profile

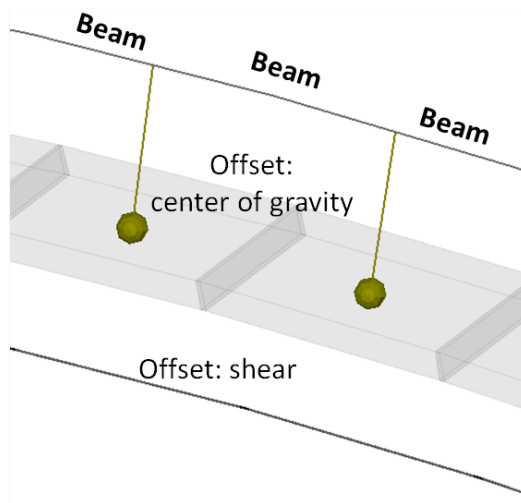

Figure 10.71: Beam visualization: center of gravity offset and shear offset

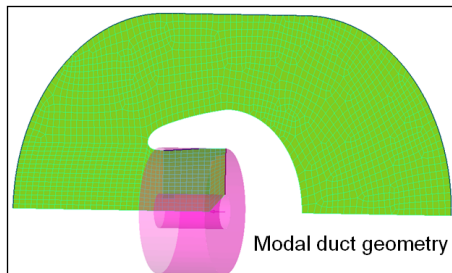

Figure 10.72: Modal duct's geometry shown in the Render window

10.6.7 Boundary Conditions

Boundary conditions (BC's) can be created via

- the right-click menu of the Model Solution Sequence node;
- the right-click menu of the Boundary conditions;
- the shortcut icon in the property window of the Analysis.

A typical BC can be edited in two steps:

1. Edit the properties of the BC;
2. Select the **Domain(s)** using the **scope selector**.

The above process is illustrated in Figure 10.73.

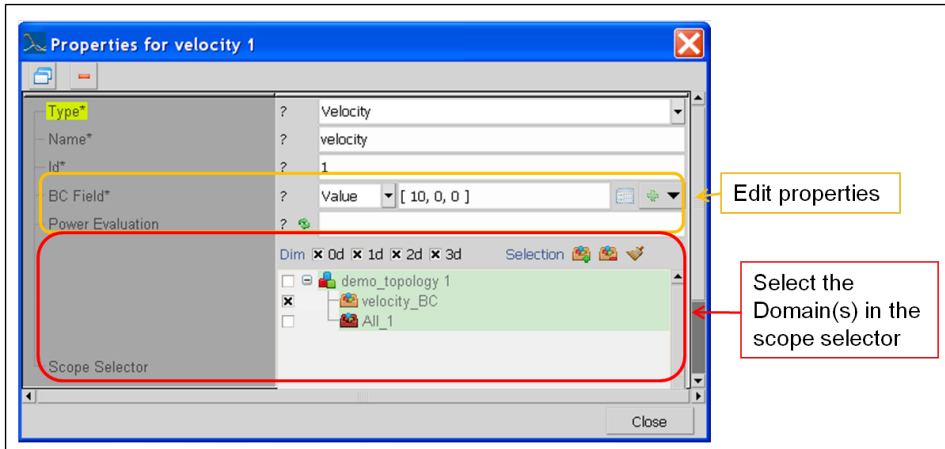

Figure 10.73: Editing a typical BC

The following types of BC's have special properties:

- The BC Mesh boundary condition does not have a **scope selector**, but a **Coupling Surface selector**. One first needs to create the coupling surface(s) and select the coupling surface(s) for the BC Mesh boundary condition. This is illustrated in Figure 10.74;
- An acoustic source does not have a scope. The coordinates of its origin need to be entered.

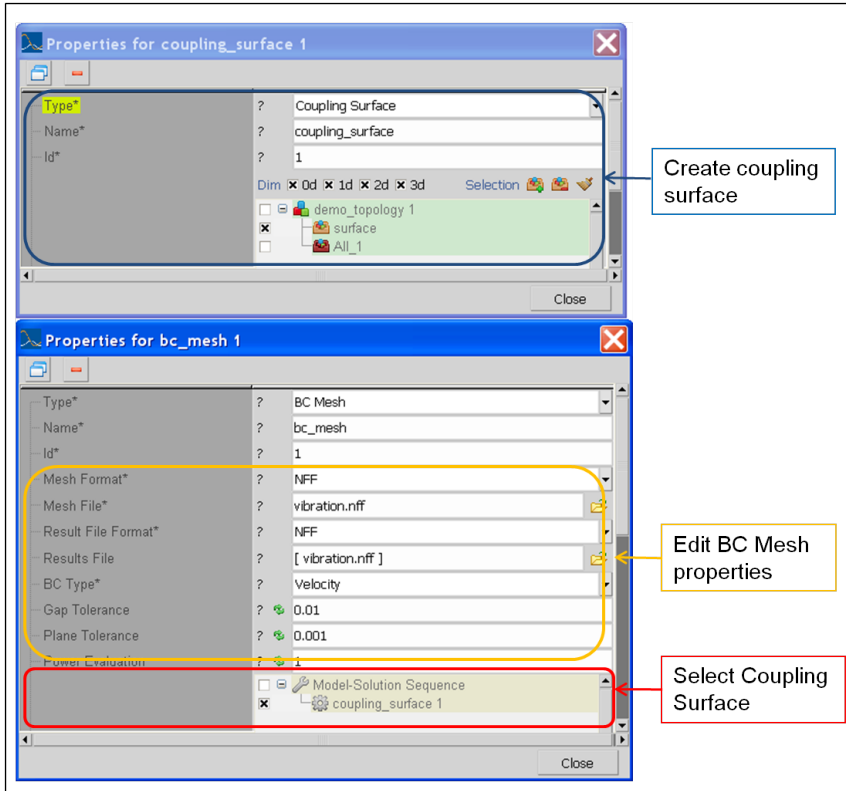

Figure 10.74: Creating a BC Mesh boundary condition

Several BC's can be visualized in the [render window](#). These BC's are:

- Acoustic sources, including cylindrical source, planar source and spherical source. The visualization is controlled by a tick box in the source's property window. Figure 10.75 shows the visualization of an acoustic source;
- Displacement, Rotation, Point Load and Point Moment. The visualization of these four BC's are controlled by a tick box in the BC's property window. The visualization is in form of arrow, triangle or square areas. The size of the visualization can be adjusted using the Scale Factor. Figure 10.76 shows an example of displacement visualization.

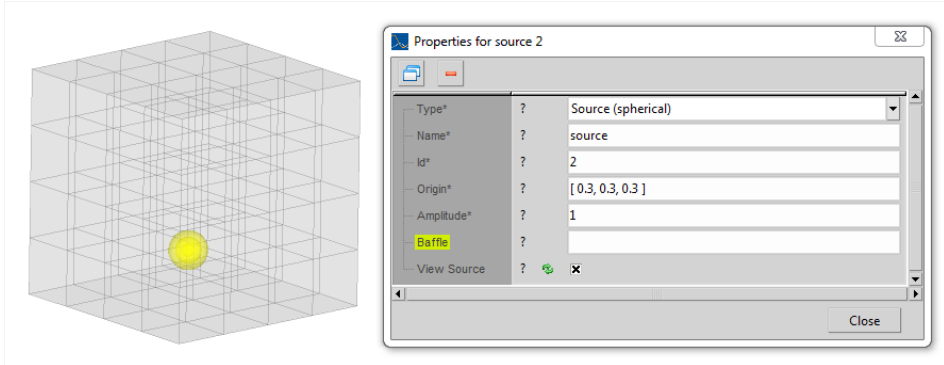

Figure 10.75: Visualization of a spherical acoustic source

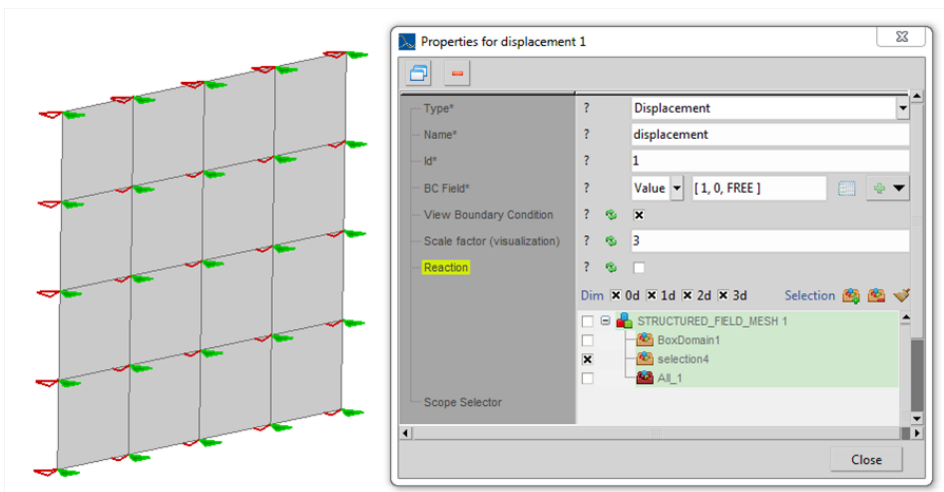

Figure 10.76: Visualization of a displacement BC

10.6.8 Loadcases

A loadcase can be created, modified and deleted through the Loadcases node. A loadcase is a combination of boundary conditions, duct modes, or acoustic sources to excite the model.

In the property window of a loadcase, contribution factors can be defined for the modes of a MODAL_BASIS (refer to ACTRAN User's Guide, Section 6.19 of Volume 2) or for the contributions of a BC_MESH (refer to ACTRAN User's Guide, Section 9.6 of Volume 2). This is illustrated in Figure 10.77.

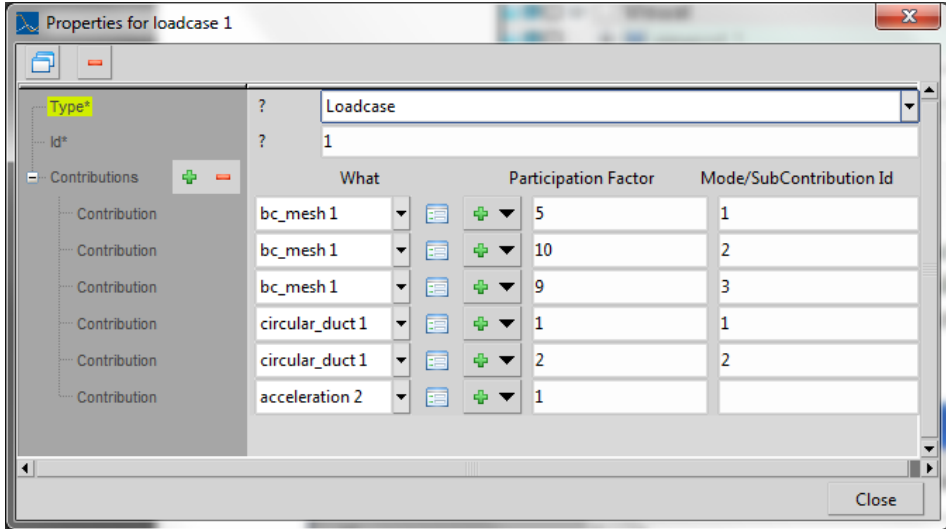

Figure 10.77: Define contribution factors in a loadcase

For more information about the loadcase, refer to ACTRAN User's Guide, Section 11.12 of Volume 2.

10.6.9 Post-Processing

The post-processing requests can be created in the Postprocessing node, as shown in Figure 10.78.

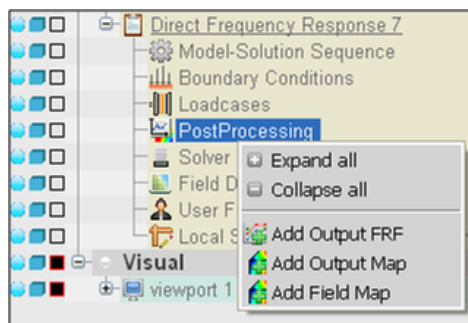

Figure 10.78: Post-processing requests

Available postprocessing requests are (some types of analysis do not have all the postprocessing requests available):

- Output FRF: defines the output parameters for the PLT file, as shown in Figure 10.79. Refer to Section 6.3.10 in this User's Guide and to ACTRAN User's Guide Section 10.8 of Volume 2 for more information;
- Output Map: defines the output parameters of map results, as shown in Figure 10.80. Refer to Section 6.3.10 in this User's Guide and to ACTRAN User's Guide Section 10.9 of Volume 2, 10.15 of Volume 2 for more information;
- Field Map: defines the output parameters for field map results, as shown in Figure 10.81. Refer to Section 6.3.10 in this User's Guide and to ACTRAN User's Guide Section 10.9 of Volume 2, 10.5 of Volume 2 for more information.

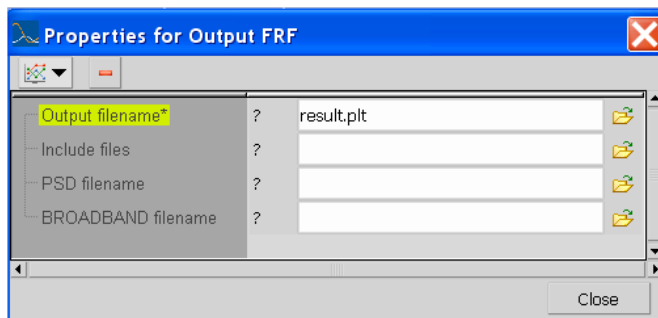

Figure 10.79: Output FRF request

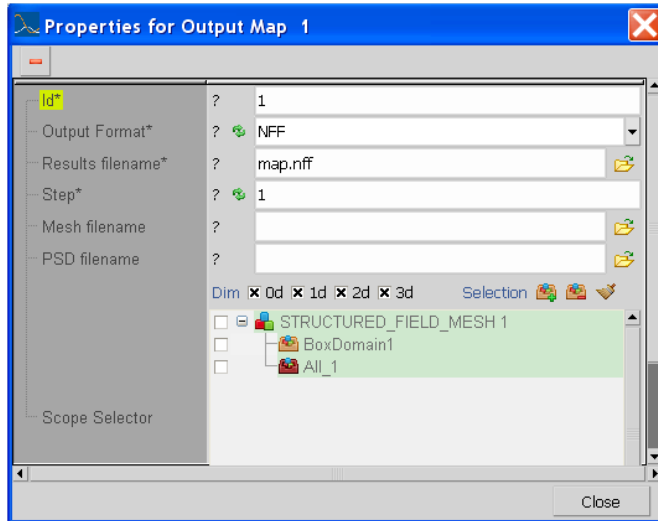

Figure 10.80: Output map request

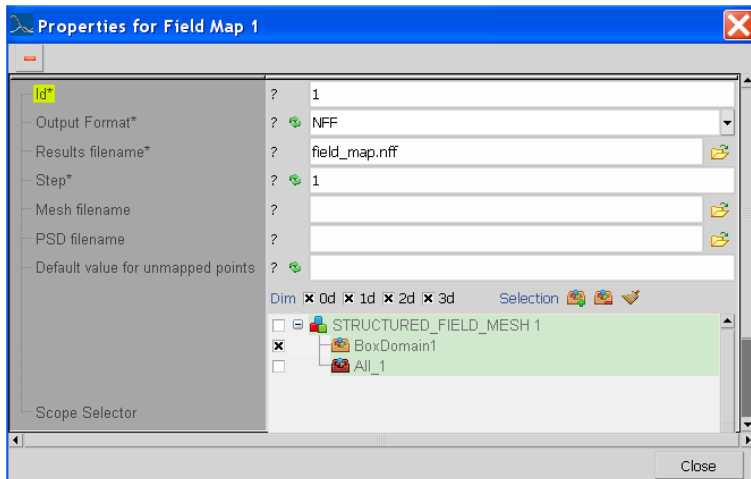

Figure 10.81: Output field map request

10.6.10 Solver

A solver can be defined via the right-click menu of the analysis, or via the right-click menu of the solver. If the selected solver requires a sub-solver, this sub-solver can be added using the right-click menu of the first solver or the related [property window](#). Figure 10.82 shows an example of the KRYLOVKRYLOV solver using a MUMPSMUMPS sub-solver.

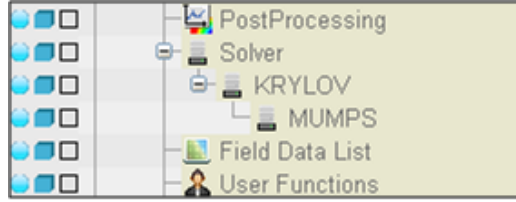

Figure 10.82: Krylov solver and MUMPS sub-solver

Please refer to the ACTRAN User's Guide, Section [11.28](#) of Volume 2 for description on the properties of a solver.

10.6.11 Field Data List

FIELDS are used in ACTRAN to define spatially dependent quantities. Most properties of component, materials, or BC's can be defined using FIELDS.

Figure [10.83](#) shows an example where the mean flow to be accounted in a convected analysis is defined using a FIELD.

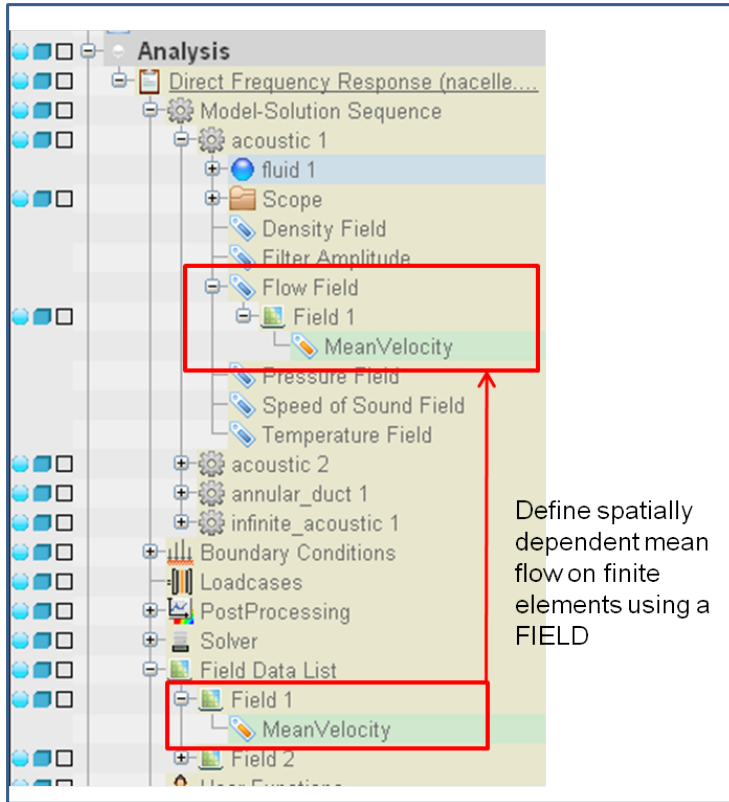

Figure 10.83: Space dependent value defined using field

The FIELDS are automatically loaded when an analysis is imported.

The user can also create a FIELD via the right-click menu of the Field Data List (Figure 10.84).

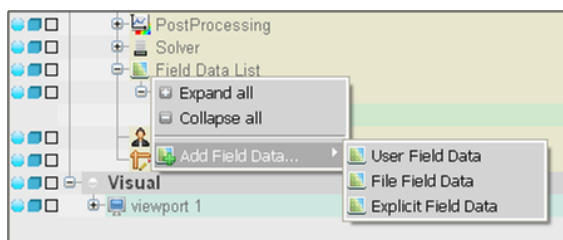

Figure 10.84: Add a field

An example of the property window of a FIELD is given in Figure 10.85.

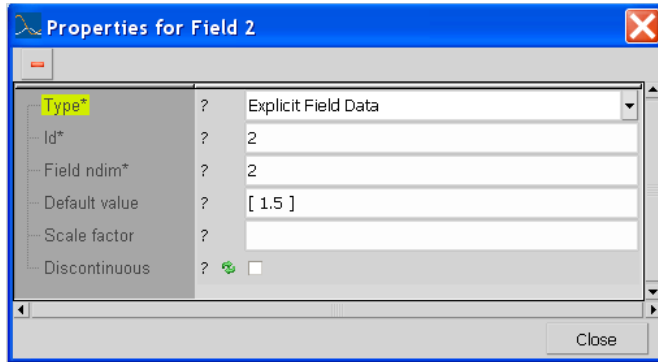

Figure 10.85: Property window of a field

Figure 10.86 shows the field data value defined under the field. To access to the field value, the user can right-click on the field data and choose "Edit Data" (Figure 10.87).



Figure 10.86: Field with field value data

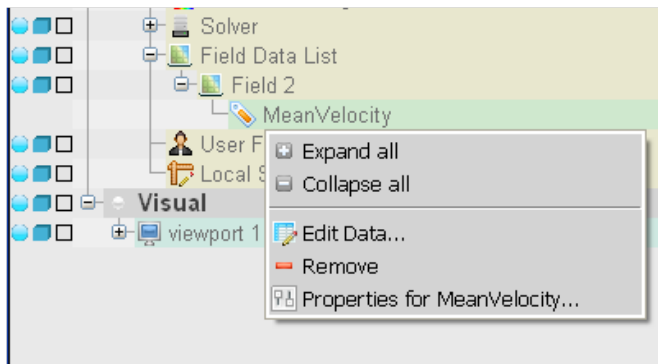

Figure 10.87: Access to the field data value

The field value data can be deleted using the right-click menu of the field data.

Deleting the field value data is important when the user wants to re-define the field value. When the field value data is defined, simply modifying the field's default value is not sufficient to re-define the field.

Refer to [Load Field](#) for more information on loading field in the analysis.

Refer to ACTRAN User's Guide, Section [11.9](#) of Volume 2 for description on the properties of FIELD.

10.6.12 User Functions

Please refer to the ACTRAN User's Guide, Section [11.36](#) of Volume 2 for description on the user function.

10.6.13 Local Axes and Transformation

The Local Axes and Transformation can be used to define local systems and transformations. Please refer to the ACTRAN User's Guide, Section [11.15](#) of Volume 2, [11.35](#) of Volume 2 for more information on the local system and transformation.

10.6.14 Adaptivity Container

Please refer to the ACTRAN User's Guide, Section [11.1](#) of Volume 2, for more information on the adaptivity container.

10.6.15 Model Reduction Container

Please refer to the ACTRAN User's Guide, Section [11.20](#) of Volume 2, for more information on the model reduction container.

10.7 Utility Analysis

Three types of utility analyses (as shown in Figure 10.88) can be created, imported and exported in ACTRANVI. They are:

- Flow mesh model for a compressible flow analysis. Please refer to ACTRAN User's Guide, Section 4.5 of Volume 2 for information on compressible flow analysis;
- ICFD input file. Please refer to ACTRAN User's Guide, Section 51 of Volume 1 for information ICFD
- FWH input file. Please refer to ACTRAN DGM User's Guide for information on FWH analysis.

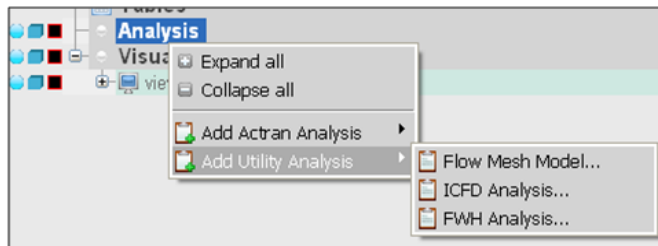

Figure 10.88: Utility analyses in ACTRAN

10.7.1 Remarks and Further Reading

- A flow mesh model can be imported into ACTRANVI using the menu File -> Import Flow Mesh Analysis; an ICFD analysis and a FWH analysis can be imported using the menu File -> Import Analysis.

10.8 Visual

The Visual tree is a container of all the [viewports](#) in ACTRANVI.

Figure 10.89 shows an example of the visual tree, with 3 viewports.

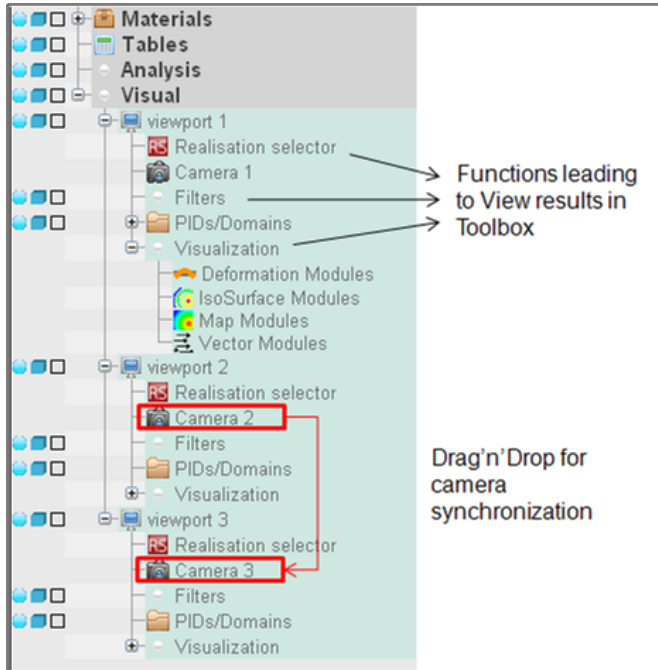

Figure 10.89: The visual tree, containing 3 viewports

10.8.1 Synchronize viewport camera

The cameras of different viewports can be synchronized individually using [drag'n'drop](#), as shown in Figure 10.89. For example, the [drag'n'drop](#) of camera 2 to camera 3 synchronizes viewport 3 with viewport 2 (viewport 3 takes the camera of viewport 2).

In order to de-synchronize the camera of a particular viewport, one can right-click on the viewport and select "Reset Camera", as shown in Figure 10.90

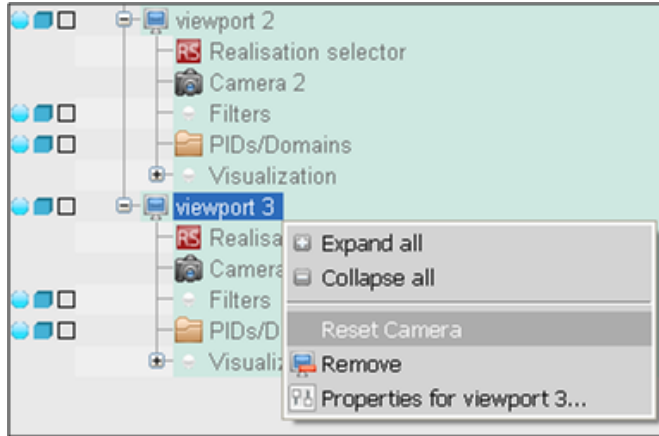

Figure 10.90: Reset camera to remove the camera synchronization

10.8.2 Remarks and Further Reading

- Refer to Section 9.3 for more information on the viewport.

ACTRANVI Toolbox

The Toolbox, located below the [Render window](#) (Figure 11.1), is composed of different tabs. It provides the following groups of functions and windows:

- Mesh creation/modification/information;

- Import and visualization of results;

- ACTRAN analysis launcher;

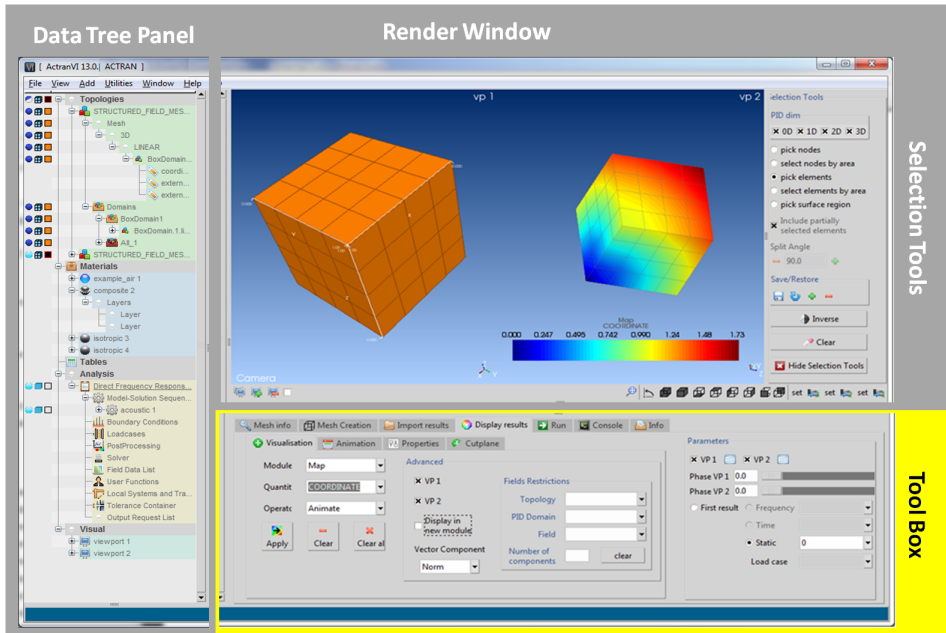

Figure 11.1: The Toolbox in ACTRANVI

11.1 "Mesh" tab

Six sub-tabs are available in the "Mesh" tab. They are: Meshing Tools, Measure, Info, Mesh Quality, Projection and Partitions.

11.1.1 "Meshing Tools" sub-tab

The meshing tools can be used to create / modify / transform a mesh. For detailed information regarding meshing tools, please refer to the [Meshing tools](#) chapter 13.

11.1.2 "Measure" sub-tab

In the "Measure" tab, one can measure the distance between two nodes, the angle formed by three nodes or the dimensions of a particular selection of pids.

1. When selecting 1 node, its coordinates are provided.
2. When selecting 2 nodes, the distance and associated vector is provided and shown. This process is shown in figure 11.2. The vector information can then be reversed (direction) or normalized to a unit length.
3. When selecting 3 nodes, the angle and associated normal vector is provided

and shown. This process is shown in figure 11.3. A permutation of the 3 points can be performed to obtain the angle between the desired selection. The vector can then be reversed in direction and normalized to a unit length.

4. When selecting one or more pid domains, the dimensions of the bounding box is provided for each axis, including minimal, maximal coordinate and local dimension. The geometrical center of the selection is provided as well as the integrated volume, surface or length (for volume, surface or edge elements) of the selection. This is shown in figure 11.4.

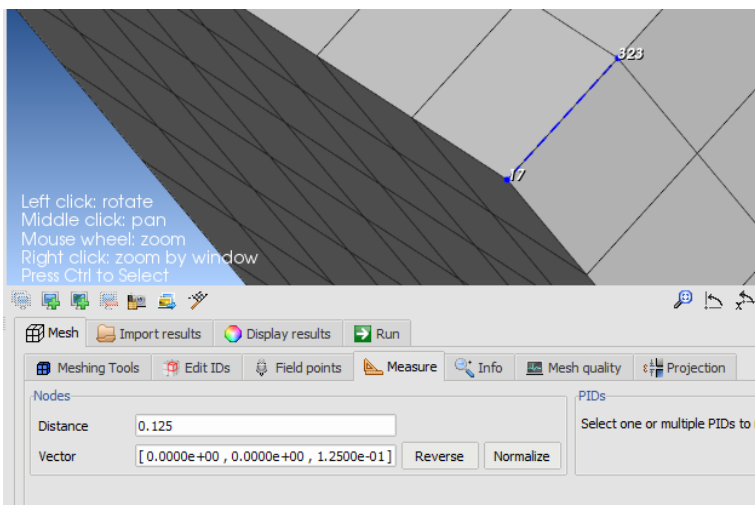

Figure 11.2: Measure distance between two nodes

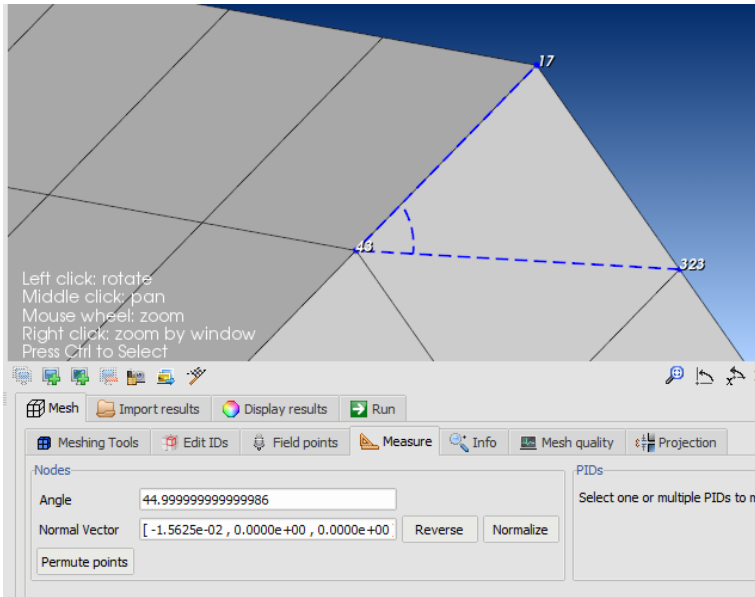

Figure 11.3: Measure angle formed by three nodes

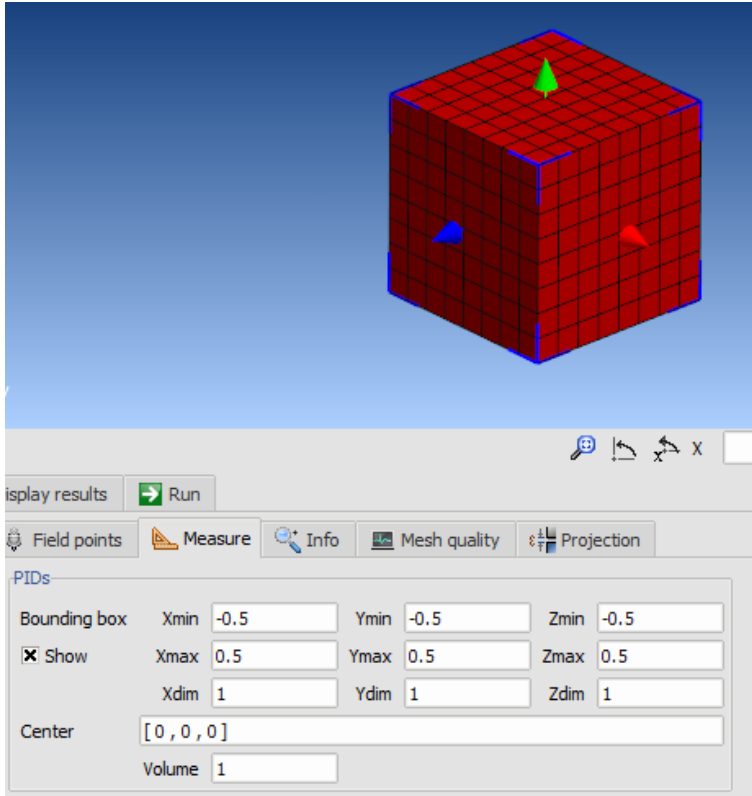

Figure 11.4: Dimensions of a selected PID

11.1.3 "Info" sub-tab

The "Info" sub-tab allow to show information regarding selected elements and nodes.

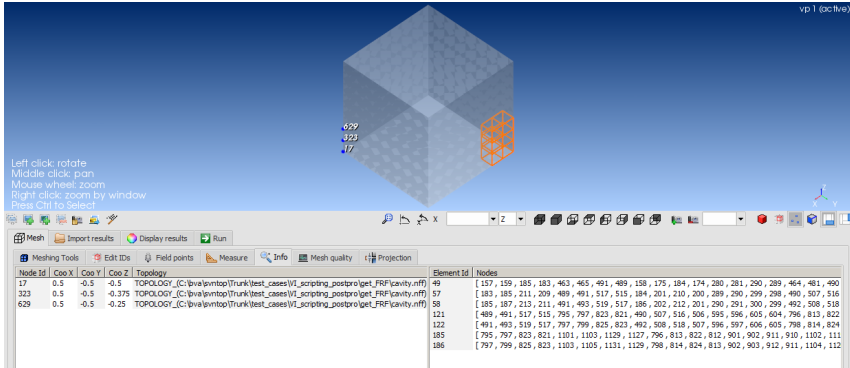

Figure 11.5: The "Info" sub-tab

The list is automatically updated with the current selection of elements and nodes.

1. For nodes, the node identification number, coordinates, corresponding topology and meshing domain is provided;
2. For elements, the element identification number, nodes, element types, dimension, interpolation, topology and PID Domain information is provided.

11.1.4 "Mesh quality" sub-tab

The Mesh quality tool provides the mesh stats and mesh quality information of the selected PID domains. The information available is: Mesh stats (1), Intersections (2), T junctions (3), Mesh criteria (4) and Mesh histogram (5) (Figure 11.6).

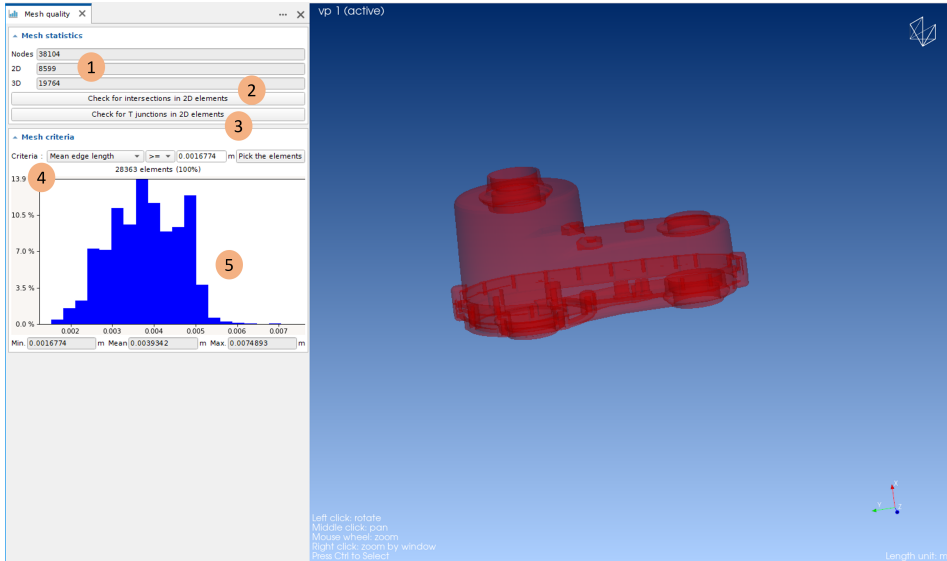

Figure 11.6: Mesh quality information

1. Mesh stats

The Mesh stats tool shows the number of nodes of the selected PIDs in total and in each dimension.

2. Intersections

The Intersections tool allows to check the intersection in one or multiple 2D PIDs. The number of intersected elements detected is reported in the log. In the render window, these elements are highlighted in green color (Figure 11.7).

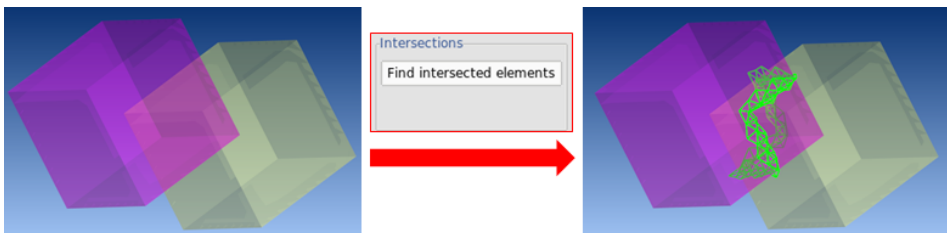

Figure 11.7: Mesh quality - Intersection tool

3. T junctions

The T junctions tool allows to detect any junction in T (or also called T branch) in different PIDs. The number of T junctions detected is reported

visually in the graphical tool. In the render window, these elements are highlighted in green color.

4. Mesh criteria filter

The Mesh criteria filter tool shows the number of elements exceed or under a selected quality criterion threshold value. These elements are displayed in bright green color in the render window (Figure 11.8).

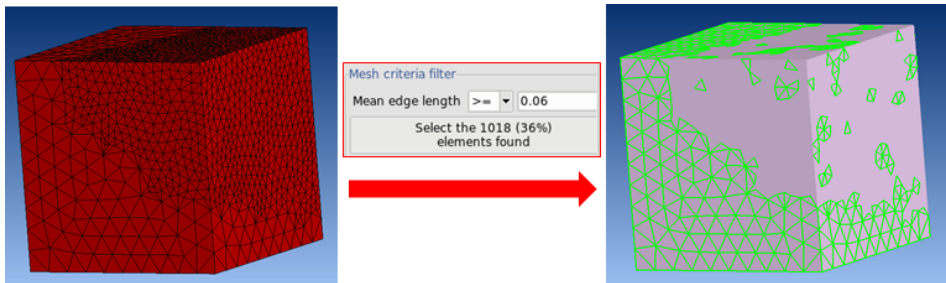

Figure 11.8: Mesh quality - Mesh criteria filter tool

Mesh histogram

The Mesh histogram tool provides mesh quality information on the elements of the selected PIDs based on the following criteria:

- Mean edge length
- Minimum edge length
- Maximum edge length
- Aspect ratio: ratio between maximum edge length and minimum edge length of the element.
- Jacobian: ratio between maximum and minimum Jacobian determinants calculated at the integration points of the element according to each type. The number of integration points used, dependent on the element type and its interpolation order, is listed in Table 11.1.4:

Element Type	Interpolation order	Number of integration points
Triangle	Linear	4
Triangle	Quadratic	7
Quadrangle	Linear	4
Quadrangle	Quadratic	9
Tetrahedron	Linear	5
Tetrahedron	Quadratic	14
Pentahedron	Linear	8
Pentahedron	Quadratic	21
Hexahedron	Linear	8
Hexahedron	Quadratic	27
Pyramid	Linear	8
Pyramid	Quadratic	27

Table 11.1: Number of integration points for each element type

11.1.5 Projection Manager

The projection tool is used for controlling the parameters and the quality of incompatible mesh projections. The projection manager tool can be used to check the consistency of the projection parameters of an INTERFACE or a BC_MESH (refer to ACTRAN User's Guide, Section 8.5 of Volume 2 and 9.6 of Volume 2). More specifically, the projection manager:

- performs the localization and mapping process;
- enables the user to test projection options (tolerance parameters);
- provides the ratio of localized nodes by the total number of nodes to map;
- automatically displays mapping quality through Maps or Contours.

The projection manager is initialized by selecting the coupling surface(s) in the PID Domains list 1 and in the PID Domains list 2. The Planar and Gap Tolerance (Min and Max values) parameters must be also specified through the Mapping Parameters section. The localization statistics are returned for each PID or domain separately. If there is more than five values, a message will appear ("Too many values to display"). This is shown in Figure 11.9:

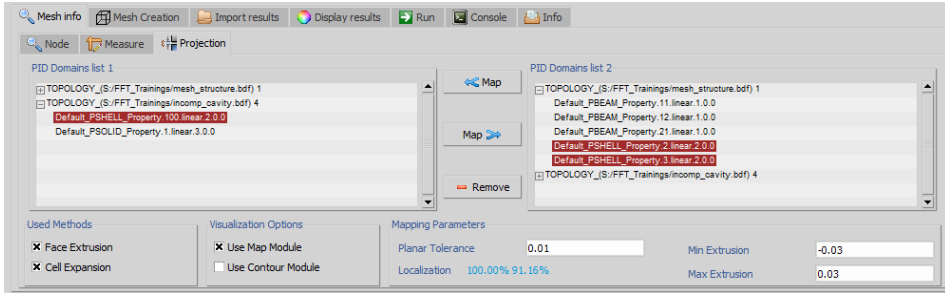

Figure 11.9: Projection tool interface

In each list, all the Topologies trees are presented. The Domains under the Topology is also available for selection. All the PID's of the Topology are presented as well. This is illustrated in Figure 11.10:

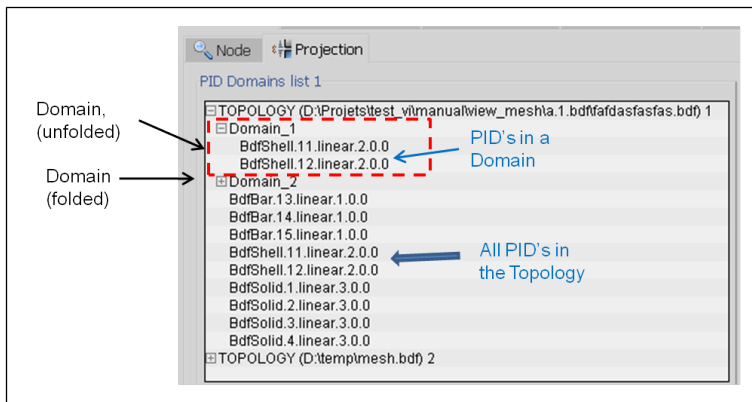

Figure 11.10: Projection tool

The direction of the array defines the Mapping direction. The Mapping process should not be confused with the Localization/Projection step. As shown in Figure 11.11, the process used is a two steps procedure:

- Projection of the nodes from surface 1 to surface 2. A temporary mesh is created based on surface 2. The normals to the nodes of surface 2 are computed. Elements of the surface 2 are extruded (from -gap tol to +gap tol) following the normal. The extruded elements are then scaled by a factor to reach target node (tolerance = plane tol).
- Values are deduced on the projected nodes on the second surface. These

values (e.g.: pressure) are interpolated from the value of the closest nodes and the shape function of the elements. For Fluid/Structure coupling (or BC_MESH), these values are then mapped on surface 1.

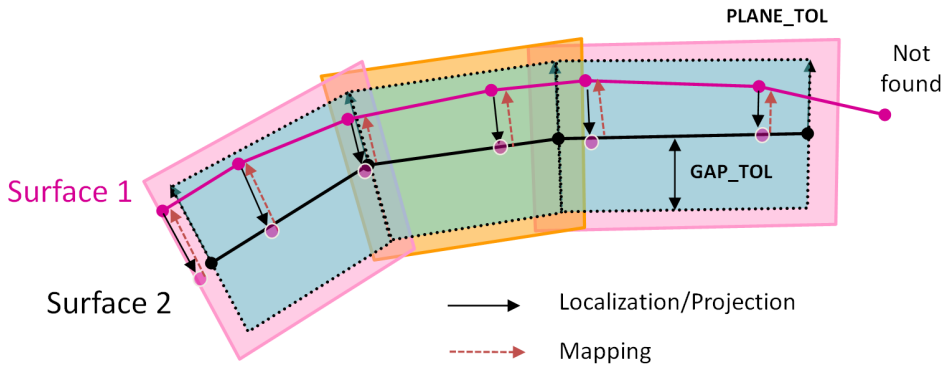

Figure 11.11: Projection Procedure

Example: To study the shell noise radiated by a muffler, an incompatible mesh is created. An INTERFACE is used to couple the structure COUPLING_SURFACE (right side of Figure 11.12) and the acoustic COUPLING_SURFACE (left side of Figure 11.12). The acoustic COUPLING_SURFACE is coarser than the structure COUPLING_SURFACE (Figure 11.12 and Figure 11.13).

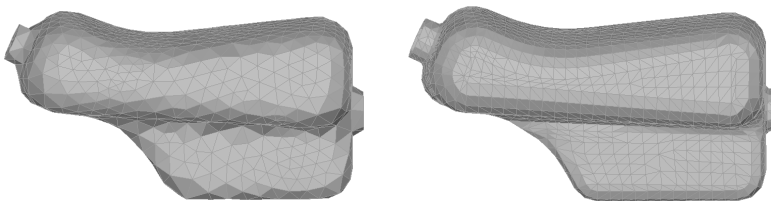

Figure 11.12: Coupling surfaces. Left: acoustic, Right: structure

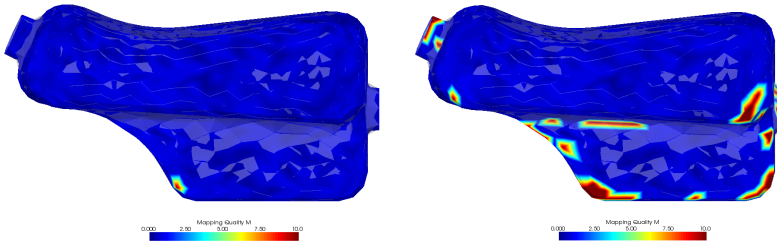

Figure 11.13: Coupling quality index for 2 values of the extrusion parameters: 5mm and 1 cm

The values displayed in the color maps provide information on the quality of the projection:

- Nodes having a value spread from 0 to 1 are mapped during the procedure.
- Nodes having a value above 1 are not mapped during the projection. The projection must be considered as a binary operation : mapped or not mapped.
- Nodes having a value close to 1 are the farthest from the projection surface. The distance still remains within the tolerance. Nodes having a value close to 0 are located at shorter distance to the projection surface.

11.1.6 Partitions

The "Partitions" tab allows to visualize and modify existing partitions of topologies. These partitions can be used for domain decomposition strategies or for Virtual SEA substructuring.

- The Partition Map section allows to select a particular partition. The Show and Clear buttons allow to visualize the considered partition. The groups considered in the selected partition will also be visible in the Groups section. Moreover, an option to apply group modifications on all partitions having the same name can be selected.
- The Group section allows to modify the content of each group. In ACTRAN, one element can only be assigned to a single group for a given partition.
 - New groups can be added;
 - Selected elements can be assigned to a selected group;
 - Elements belonging to a particular group can be selected;

- Elements of a particular group can be shown;
- Elements can be removed from a selected group.

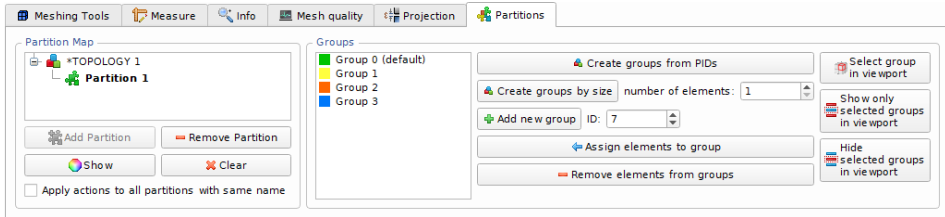

Figure 11.14: Partitions tool

11.2 "Import results" tab

In order to visualize the results of a computation, two steps are needed. The first step is to use the Import results tab to import the results from a results database. The second step is to use the [Display results](#) tab to visualize these results.

Concerning the results import, two cases are discussed below:

- The results file is different from the mesh file. This is for example the case where the mesh is in a BDF file and the results in a OP2 file. In this case, one needs to first choose a mesh, then use the "Add File(s)" menu to add the results on the mesh. After the results are added to the mesh, select the desired quantity in the results and click on "Import Selection" to import the results. This process is illustrated in Figure 11.15;
- The results file contains the mesh and is already loaded. This is for example the case for an NFF database. In this case, the quantities available in the database are already presented in the window. One only needs to select the desired quantity and import it by clicking on "Import Selection". This process is illustrated in Figure 11.16.

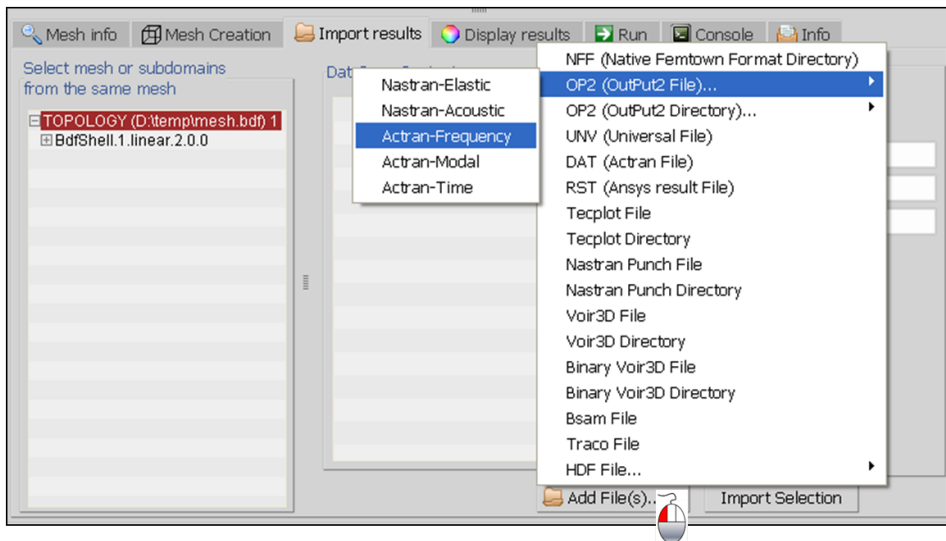

Figure 11.15: Import results: result file is different from the mesh file

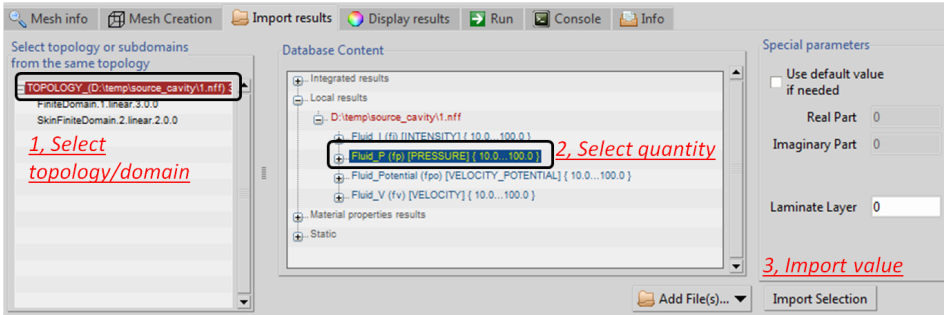

Figure 11.16: Import results: result file is the same as the mesh file

Results can also be imported on a single frequency or on a selected number of frequencies. Figure 11.17 shows the related operations.

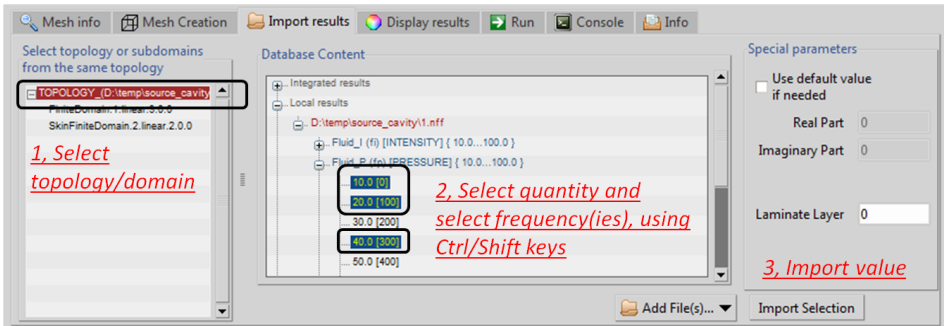

Figure 11.17: Import results: select results on certain frequency(ies) to import

When the results are imported on selected frequencies, a text (imported) appears after the frequencies, illustrated in Figure 11.18.

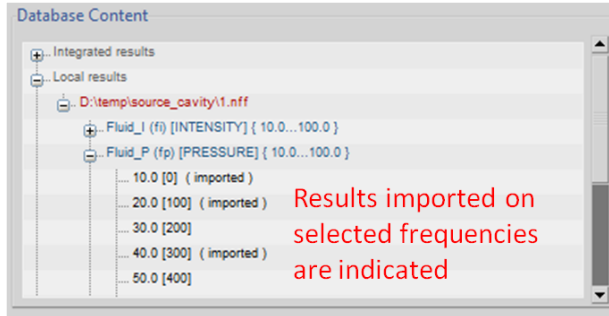

Figure 11.18: Import results: Imported results are indicated by a text

A loaded result file can be removed from the Database content. Figure 11.19 illustrates the process.

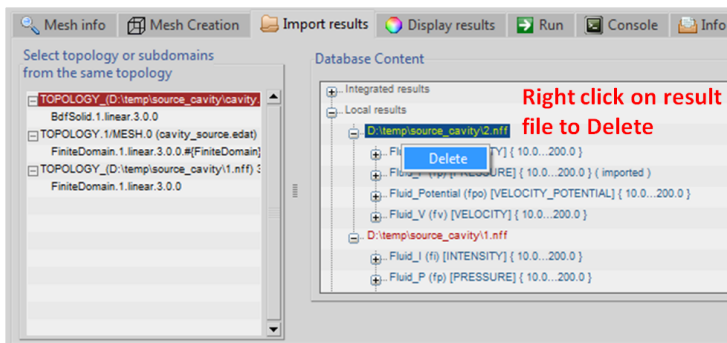

Figure 11.19: Import results: An imported result file can be removed in the Right Click menu of the result file

The imported results appear under the mesh in the **Topology** tree. The results can be removed by Remove in the right-click menu of the results. This is shown in Figure 11.20

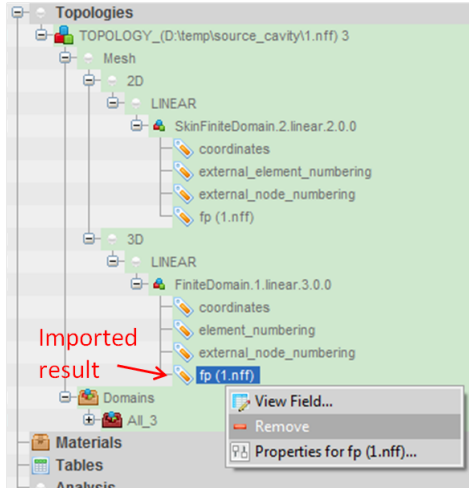

Figure 11.20: Import results: Imported results are show under the Topology and can be removed

If the results are not available for some nodes of a domain, the results of the entire domain are not imported, except if the "Use default value if needed" option is selected. This is illustrated in Figure 11.21.

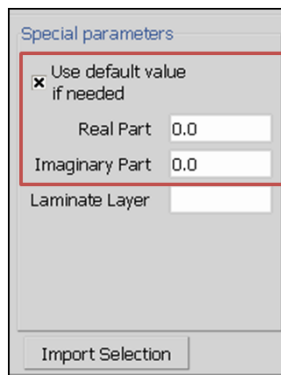

Figure 11.21: Import results: specify default value

When importing results on a 2D shell domain modeled with composite material (shell with multiple layers), one can choose to import the results on one of these layers. This is done using the Laminata layer option, shown in Figure 11.22.

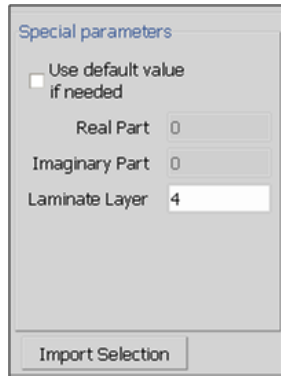

Figure 11.22: Import results: specify the layer to import results for composite shell

In case the user imports a NASTRAN .OP2 file, two more options become available. When the results contain stress/strain information, the option "Element to Basic Coordinate System (stress/strain)" can be activated in order to change the element coordinate system to the Basic one. When the results contain modal information (dsplacement/rotation), the option "Modes in Local Coordinate System (displacement/rotation)" can be activated to change the coordinate system from Global to Local.

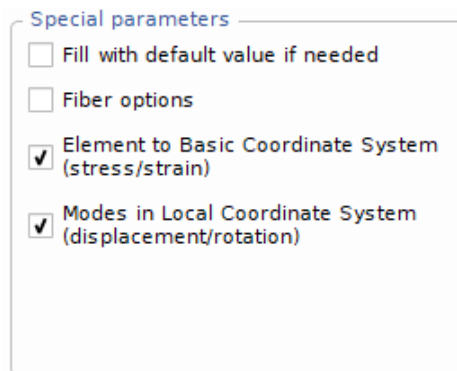

Figure 11.23: Import results: modify the coordinate system for NASTRAN files

11.3 "Display results" tab

The Display results tab is used to display the results of a computation. Before visualizing the results, the results must be imported using the [Import results](#) tab (Section 11.2).

11.3.1 Visualization

The Visualization tab is used to plot and/or remove the results.

Figure 11.24 illustrates the process of plotting a scalar result (one dimension) such as the pressure or the density.

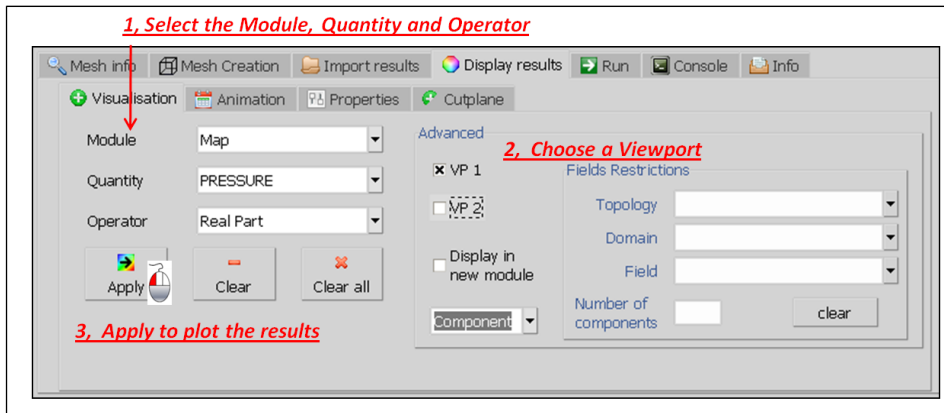

Figure 11.24: Plot a scalar result

Figure 11.25 illustrates the process of plotting one component of a vector result (multiple dimension) such as the intensity, the displacement or the velocity.

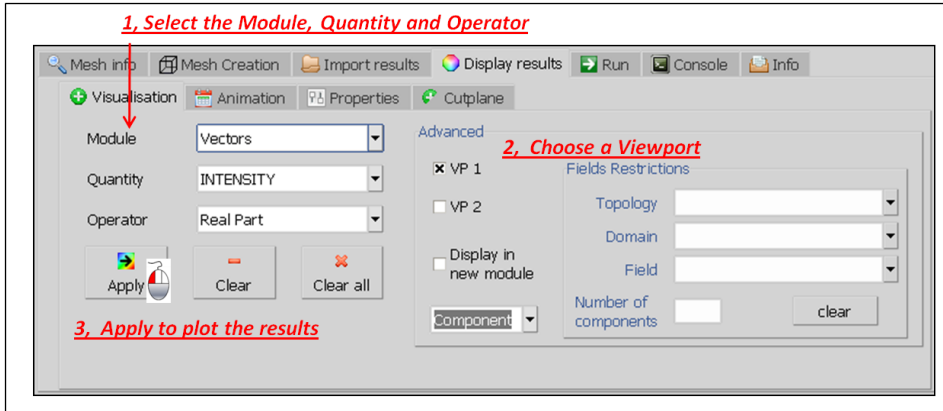

Figure 11.25: Plot a component of a vector result

Five different visualization modules are available:

- The map module applies a color map of values on the mesh;
- The isosurfaces module computes surfaces of identical values and creates a dedicated mesh for each value;
- The vectors module is used on vector quantities, and creates a colored vector representing the value on each node of the mesh;
- The deform module is used on vector quantities, and modifies the mesh according to the vector. Typically, displacement are shown using the deform module to highlight the deformation;
- The directivity map module is applied on scalar quantities only, and combines a map of the quantities based on the provided operator, with a deformation of the surface mesh. This deformation is proportional to the provided value, and is scaled between the provided or automatically computed center of the directivity and the grid point. A second operator for this deformation can be selected.

In the Advanced box, the user has access to advanced controls on the visualization of the results:

- VP: choose the viewport(s) on which the results are displayed;
- Display in new module: when plotting a new result, the colored range of the result is shown in a new bar;

- Vector component: choose the component of a vector. If no component is chosen, the modulus of the vector is plotted;
- Rotating mode: choose the rotating mode if available (only applicable to rotating components). If no mode is chosen, the first available mode will be displayed;
- Field restrictions: the user can choose the restrictions on the results. These options are useful when the user wants to plot the results only on a particular topology or domain.
- For the directivity map, the center of the directivity is either manually provided, or automatically computed. Baffle planes can be provided when computed automatically. a particular operator for the deformation of the directivity can be provided as well.

On the right part of the tab, the user can adjust parameters modifying the results displayed on the [render window](#):

- VP: to select which viewport is impacted by the change of the parameters
- Phase VP: to modify the phase at which the results is plotted. As ACTRAN is producing complex results, one can display the results with a specific phase shift. Slide bar can be used or the value can be directly indicated in the dedicated entry field.
- First result checkbox : by checking this option, ACTRANVI plots the results for the first available frequency (or time step).
- Frequency selector : user can select the frequency at which the results must be plotted. ACTRANVI proposes the frequencies having been imported using the [Import results](#) tab.
- Time selector : user can select the time step at which the results must be plotted. ACTRANVI proposes the time steps having been imported using the [Import results](#) tab.
- Static selector : user can select the static id at which the results must be plotted. ACTRANVI proposes the static id having been imported using the [Import results](#) tab.
- Loadcase id selector : ACTRAN solver features multiple loadcase simulations see Section 11.22 of Volume 2. At each frequency, the selected quantity is available for all the different loadcases defined in the analysis. User can display the quantity for a specific load case by using the loadcase id selector.

This is illustrated in Figure 11.26.

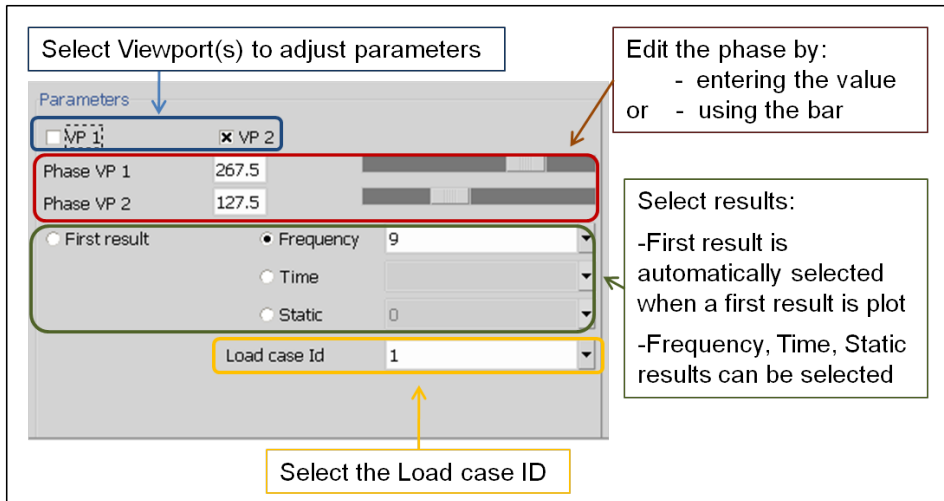

Figure 11.26: Adjust the results parameters

11.3.2 Properties

In the Properties tab, the properties of the results visualization can be changed. Figure 11.27 and Figure 11.28 show the available properties for a map module and for the vector module, respectively.

Below are explanations of several common properties:

- Custom range: allow user specifying the range of the colorbar. If the box is not checked, an automatic range is applied based on minimum and maximum value available on the domains;
- Log scale: use log scale intervals for the colorbar;
- Centered scale : set the colorbar values centered around zero
- Map values before color interpolation: when plotting a colored map, interpolate the value in the elements according to the values on the elements' nodes. If the option is not activated, the above operation is not performed; the color in the elements is interpolated according to color on the elements' nodes;
- When deactivating the mapping of the values, a particular color above and below the provided range can be specified;

- The Formatting of the numbering, as well as the number of labels and colors of the colorbar can be chosen individually;
- Type allows to choose the type of colormap to use. Several types are available (jet, blue white red, seismic, spectral, viridis, plasma, inferno, magma, rainbow, cubehelix).
- The Geometry argument provides the scale and position of the colorbar. When moving or modifying this latest manually, the Geometry argument is automatically adapted;

For the map operator, an integration tool over the frequencies, time values or loadcases is available. When integrating over frequency or time, 3 options can be activated: integration, sum or mean value. For loadcases, only a sum or mean value can be computed. Depending on the provided operator and number of quantities, for obtained integrated solution becomes:

- For a real operator:

$$\sqrt{\int (q1.real^2 + q2.real^2 + q3.real^2)df} \quad (11.1)$$

where q1, q2, q3 represents the different components of the vector. For a scalar value, q2 and q3 are equal to 0.

- For an imaginary operator:

$$\sqrt{\int (q1.imag^2 + q2.imag^2 + q3.imag^2)df} \quad (11.2)$$

- For a norm operator:

$$\sqrt{\int (q1.real^2 + q2.real^2 + q3.real^2) + (q1.imag^2 + q2.imag^2 + q3.imag^2)df} \quad (11.3)$$

- For a dB operator:

$$10 * \log_{10} \left(\int \frac{(q1.real^2 + q2.real^2 + q3.real^2) + (q1.imag^2 + q2.imag^2 + q3.imag^2)}{p_{ref}^2} df \right) \quad (11.4)$$

where p_{ref} corresponds to the reference pressure.

- For a dBA operator:

$$10 * \log_{10} \left(\int \frac{((q1.real^2 + q2.real^2 + q3.real^2) + (q1.imag^2 + q2.imag^2 + q3.imag^2)) * A^2}{p_{ref}^2} df \right) \quad (11.5)$$

The different options modify the above the expressions as follows:

- Using the Sum option replaces the integration by a sum over the frequencies, time or loadcase values:

$$\sqrt{\sum_{i=1}^N (q1.real^2 + q2.real^2 + q3.real^2)} \quad (11.6)$$

- Using the Mean option replaces the integration by a discrete sum divided by the number of frequencies, time or loadcases :

$$\sqrt{\frac{1}{N} * \sum_{i=1}^N (q1.real^2 + q2.real^2 + q3.real^2)} \quad (11.7)$$

Particular properties for the isosurfaces module:

- Number of isosurfaces: Specifies the number of intermediate isosurfaces. By default, the isosurfaces corresponding to the min and max value are not accounted.

Particular properties for the vector module:

- Scale factor: the scale factor of the vector arrow;
- Scale vectors: the length of the arrow representing a vector is proportional to the modulus of the vector.

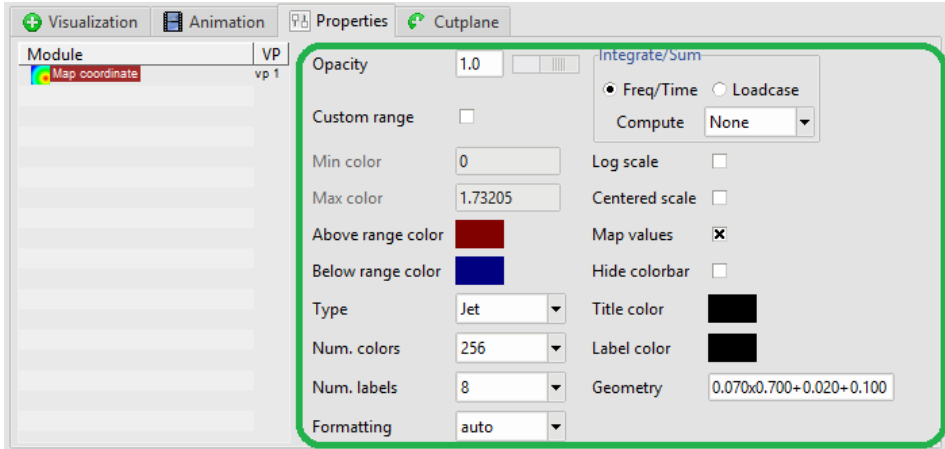

Figure 11.27: Properties of a map module

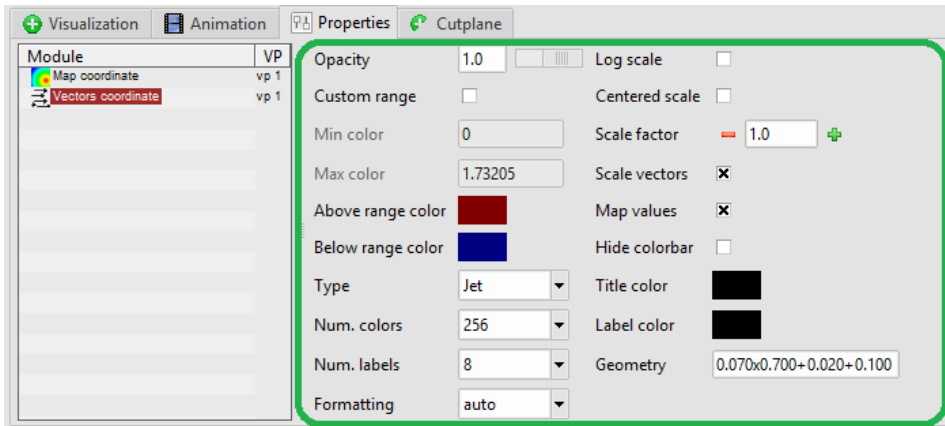

Figure 11.28: Properties of a vector module

Particular properties for the deform module:

- Scale factor mode: Specifies the scale factor mode which can be absolute (multiplication of the quantity with this constant factor) or relative to the maximum of the quantity.
- Scale factor: A real, positive number which will define the size of the scaling
- Undeformed wire mesh: Toggle to show the undeformed wire mesh

- Undeformed surface mesh: Toggle to show the underlying undeformed surface

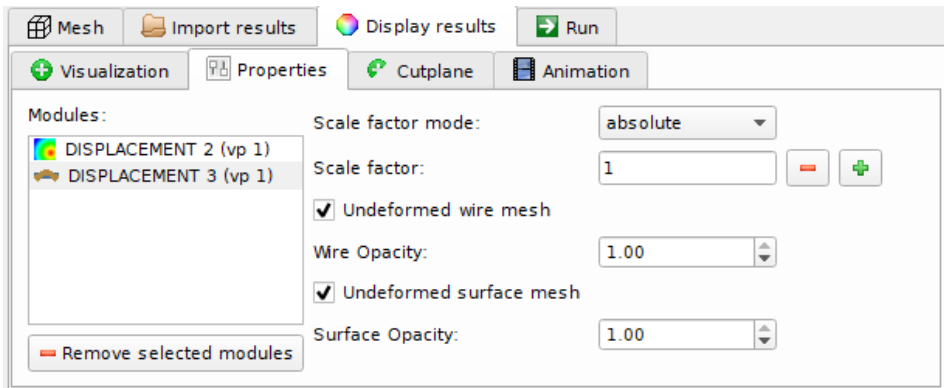

Figure 11.29: Properties of a deform module

11.3.3 Cutplane

The Cutplane tab is used to create cutplanes on the results and enable the user to inspect results inside the mesh.

In order to create a cutplane in the Cutplane tab (Figure 11.30), the user first selects the result to cut, through the combination of four parameters. When clicking on "Apply", a cutplane is created.

To improve the visualization of the mesh after a cutplane operation, one may need to adjust the [visibility](#) in the [data tree panel](#) in order to have a desired visibility of the mesh.

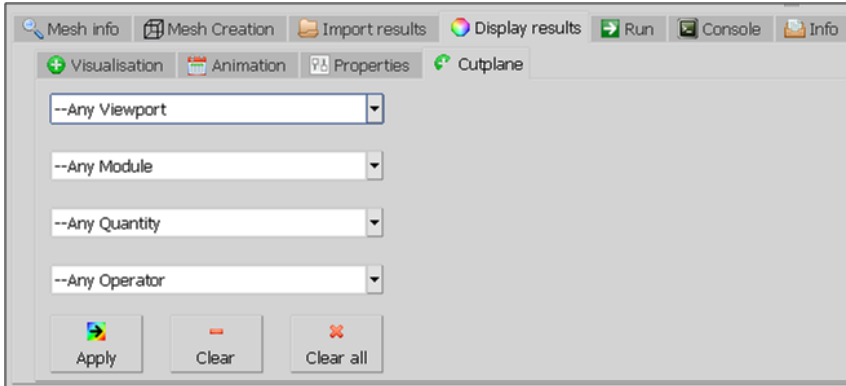

Figure 11.30: Create a cutplane

Once the cutplane is created, its properties can be modified in the Properties tab, as shown in Figure 11.31.

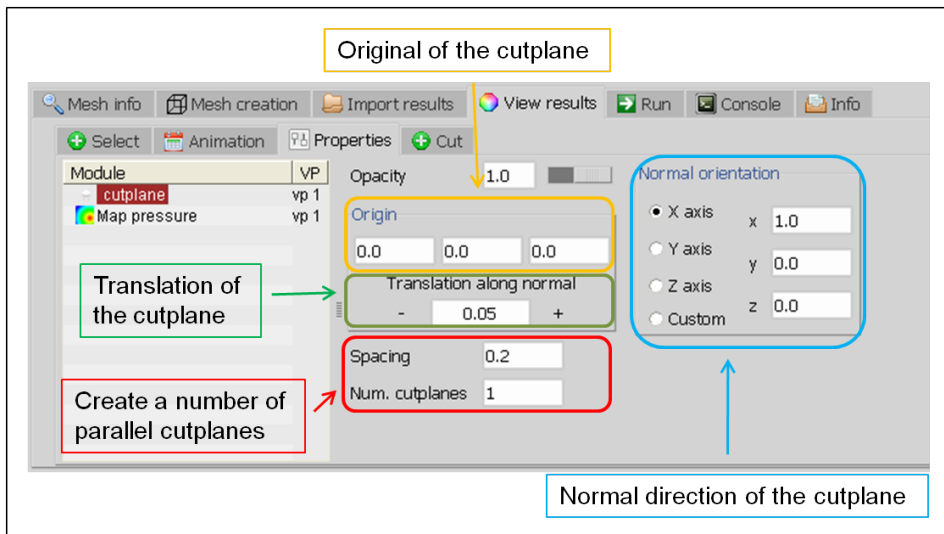

Figure 11.31: Properties of cutplane

11.3.4 Animation

The animation tab is used to create an animation of the results. The animation can be saved in a video file or in a set of image files. The animation tab is shown in Figure 11.32.

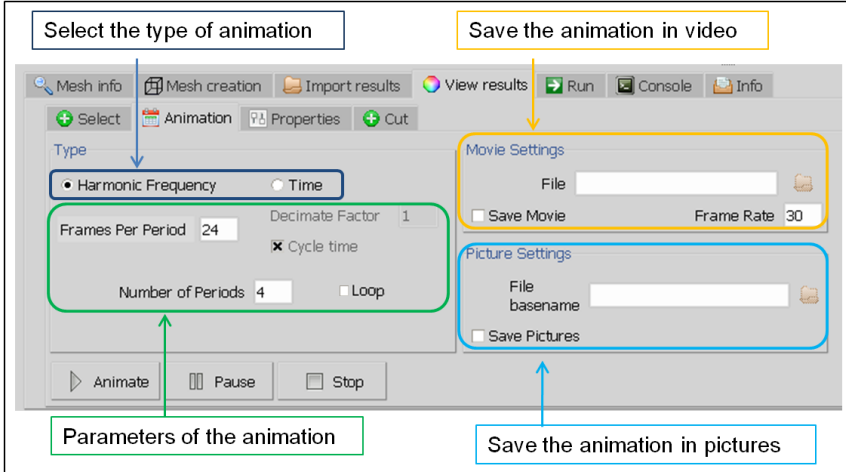

Figure 11.32: Animation tab in Display results

11.4 "Run" tab

In the Run tab, an analysis in ACTRANVI can be launched or validated. Figure 11.33 shows the content of the Run tab.

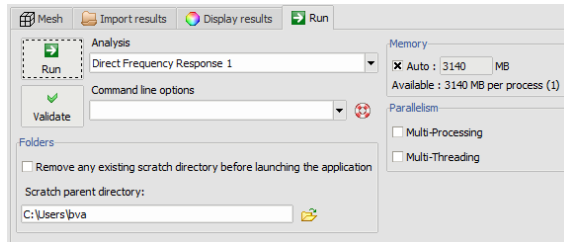

Figure 11.33: Run tab to launch an analysis

The Analysis toggle allows to select the analysis to be launched using the launcher. The command line options allows to specify particular commands to be used. The memory and parallelism sections allow to easily specify the dedicated amount of memory for the computation or to select the parallel options.

Alternatively, a Validate function allows to run the computation in test mode to verify the validity of the analysis. The following validation options are available in the Validate modes list:

- **light**: only builds the model (without testing the solver operation);
- **adaptivity**: builds the model and runs the solver (without factorization) only for the first frequency. For cases with mesh adaptivity, all mesh iterators are tested with their corresponding first frequencies;
- **full**: runs the full case (all frequencies, solver without factorization), creates empty results (*.plt, nff) and a report.pdf

It is also possible to run a validation of an existing analysis in the command prompt through the `--test` option. Please refer to Section ?? of Volume 1 for further information.

11.4.1 Remarks and Further Reading

- The exported analysis file in the EDAT format. It is named: `analysis_type.yyyy.mm.dd-hh.mm.ss.edat`. For example: `"Direct_Frequency_Response_2020.01.28-11.14.10.edat"`;
- The export of the analysis is recorded in the [session](#); the launch of the

analysis is not recorded in the [session](#).

11.5 Console and Info frame

The console and info frame (Figure 11.34) can be shown by clicking on the button located on the bottom left corner of ActranVI

The [session](#) script is automatically printed in the console tab . The user can also type the API commands in order to execute functions from the Console.

Information related to the application is printed in the Info tab

```

ActranPython Console v2.7.5 (default, Nov 15 2013, 16:40:24) [
MSC V.1700 64 bit (AMD64)] by Free Field Technologies <www.fft
.be>
>>> actranvi = ActranVI()
>>> [bid_domain] = actranvi.create_box_surface_mesh(origin=[0,
0,0,0,0,0], dimensions=[1,0,1,0,1,0], element_size=0.1, element_t
ype='trial', rotation_angles=[0,0,0,0,0,0])
>>> analysis_1 = actranvi.add_analysis(type='Direct Frequency
Response')
>>>

...done ( Mesher : Print internal data )
-- Mesher info, --
Delete domain inheritance of raw mesh vertices
Mesher : Delete unused vertexes
-- Mesher info, --
Delete 0 vertexes
...done ( Mesher : Delete unused vertexes )
...done ( Mesher : Export domain group )
...done ( Mesh tool : Box )
Mesher : Destroy
...done ( Mesher : Destroy )

```

Figure 11.34: Console tab

11.5.1 Remarks and Further Reading

- Please refer to Chapter [27](#) and [29](#) for more information related to the session and to API.
- When reporting a problem to the Hexagon support team (see Section [3.2](#) for the contact information), please attach the information content in your Email.

11.6 BC_MESH split utility

The BC_MESH split utility can be used to automatically create BC_MESH boundary conditions, in order to compute the contribution to the acoustic radiation from specific structure areas of the original BC_MESH. The split functions can be accessed by right-clicking on a BC_MESH boundary condition (Figure 11.35)

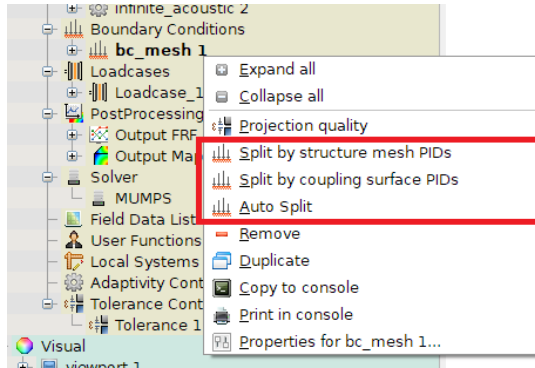

Figure 11.35: The three functions of the BC_MESH split utility

Three functions are available :

- Split by structure mesh PIDs: the structure mesh PIDs are retrieved from the specified BC_MESH mesh file. Each structure mesh PID is set as a source PID in a new BC_MESH.
- Split by coupling surface PIDs: all the PIDs included in the scope of the BC_MESH coupling surface are identified. A coupling surface is created based on each one of those PIDs and this coupling surface is used in a new BC_MESH
- Auto-split: performs the partition of the coupling surface according to the projection of the different structure PIDs and the creation of the related COUPLING_SURFACE datablocks. This option is equivalent to setting SPLITTING_METHOD to AUTO in RADACT

All the other parameters from the original BC_MESH are preserved in the BC_MESH boundary conditions resulting from the split. A loadcase is created for each BC_MESH (except for the original BC_MESH if it already has a related loadcase). In case of an id collision with an existing loadcase or BC_MESH, a pop-up allows the user to abort the operation or automatically change the loadcase or BC_MESH id. In case the user chooses to change the id, the loadcase

and BC_MESH ids will no longer correspond to the original structure or coupling surface PIDs.

11.7 BC_MESH mode contribution utility

The BC_MESH mode contribution utility can be used to automatically create a BC_MESH calculation where each mode radiates independently according to the modal participation factors output by the hybrid frequency response that has been previously run. Multiple loadcases will be generated automatically and each of them represents a contribution for each mode. (Figure 11.36)

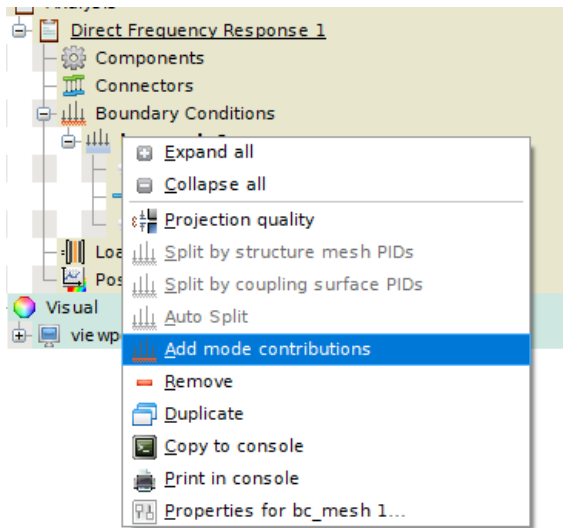

Figure 11.36: Mode contribution utility of the BC_MESH

11.8 Poles Fitting utility - DGM Porous Materials

The Fitting Poles tool can be used to compute the damper factors, gains and poles used to fit an equivalent Miki porous material in Actran DGM. It is available in the Tools tab

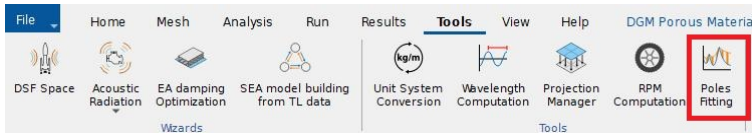

Figure 11.37: Fitting Poles tool inside Tools tab ribbon

The tool will compute the damper factors, gains and poles based on the following input parameters:

- Frequency range for fitting
- Static mean pressure and density in the equivalent fluid material
- Constant heat pressure and volume in the equivalent fluid material
- Target flow resistivity of the Miki material

The damper factors, gains and poles can then be obtained by the utility and copied to a pair of Analytic Tables (DGM Treatment) and then referenced in an appropriate porous DGM material. The user can check the accuracy of the fit using the P factors and V factors comparison graphs integrated in the tool.

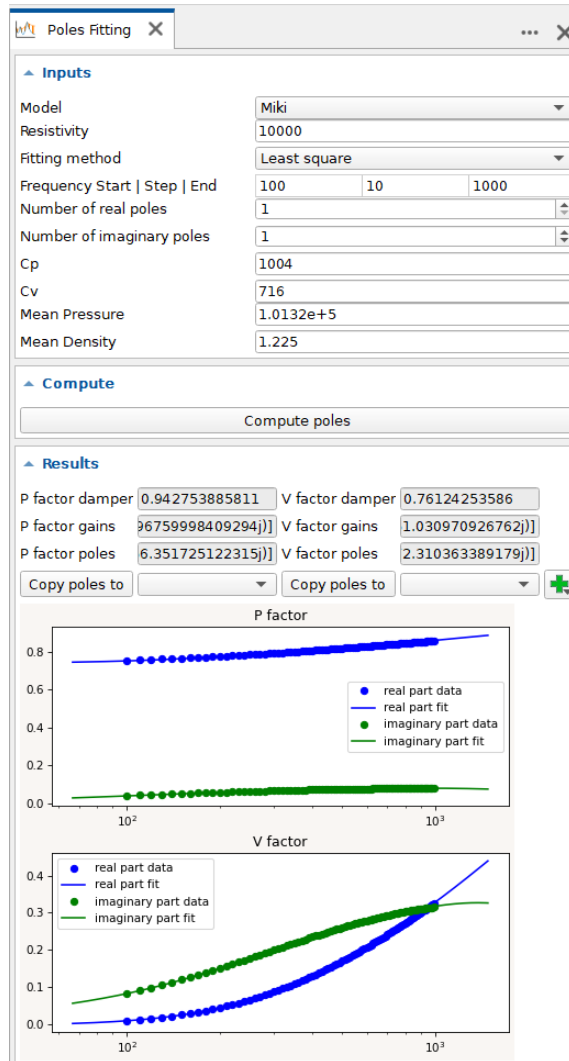

Figure 11.38: Poles Fitting tool - Miki Model

11.9 Poles Fitting utility - DGM Surface Conditions

The Fitting Poles tool can also compute the gains, poles and mass, stiffness and damping factors for expressing multi-frequency impedance, admittance and transfer admittance boundary conditions in Actran DGM. As input, the iterative "Table" or "Acoustic Liner" fitting model requires the following:

- A frequency table as the fitting target if "Table" model is used

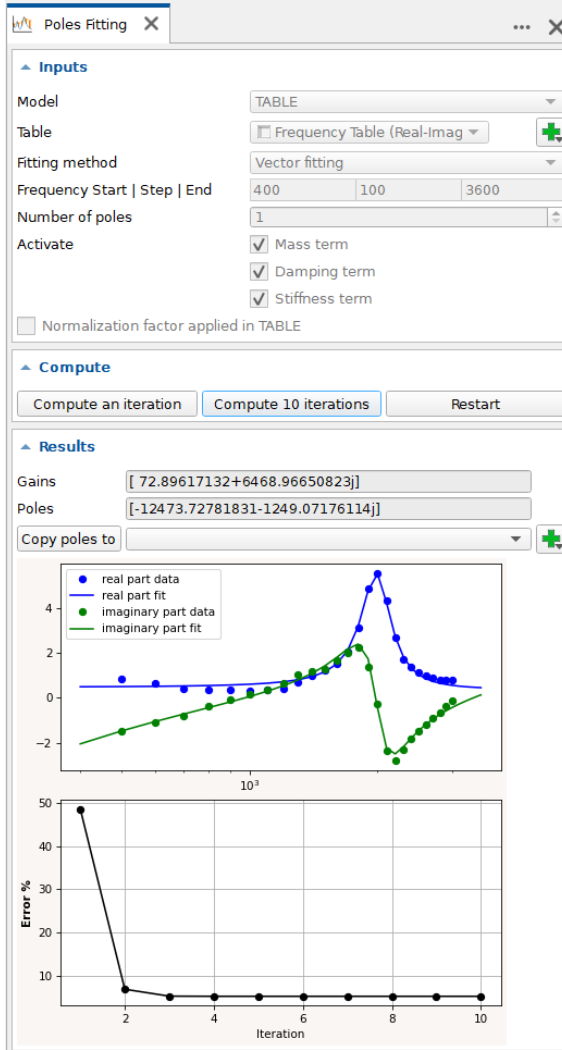

Figure 11.39: Poles Fitting tool - Table Model

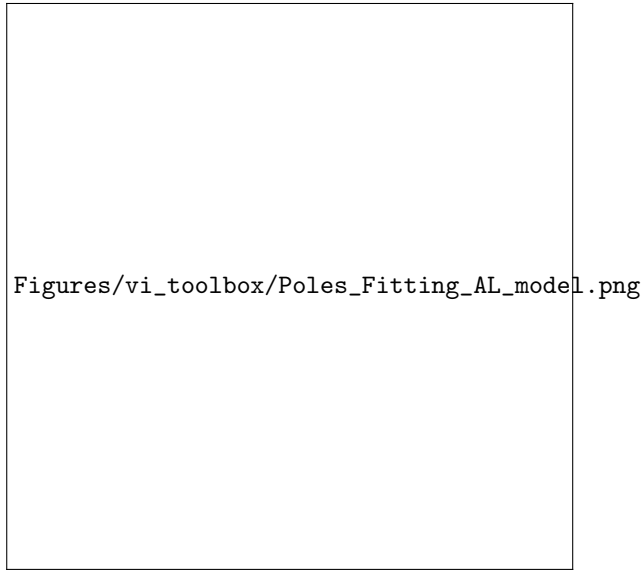

Figure 11.40: Poles Fitting tool - Acoustic Liner Model

Selection Tools

12.1 Selection Handling

For selecting entities inside the render window, the four following selection modes are available:

- PID (element set) selection mode
- Element selection mode
- Node selection mode
- SubElement selection mode

Selection mode icons can be found on the icon bar at the bottom right of the render window, as depicted in figure 12.1.

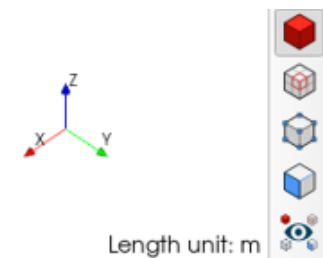

Figure 12.1: Four selection modes are available. From top to bottom: PID, Element, Node and subelement

The default selection mode when opening ACTRANVI is the PID selection mode. The four selection modes are detailed in the following sections.

12.1.1 PID (element set) selection mode

1. Element sets can be selected by left clicking on the element set name in the data tree, whichever selection mode is the active one. (Ctrl + left click) allow for multiple element sets selection in the data tree
2. Element sets can also be selected by picking (Ctrl + left click) in the render window. The PID selection mode should be the active one
3. The selected element sets are colored in red in the data tree and in the render window. The selection is synchronized between the data tree and the render window
4. Turning off the visibility of an element set from the data tree removes this element set from the current selection (if the element set was in the current selection). If the current selection contains other element sets, these remain selected

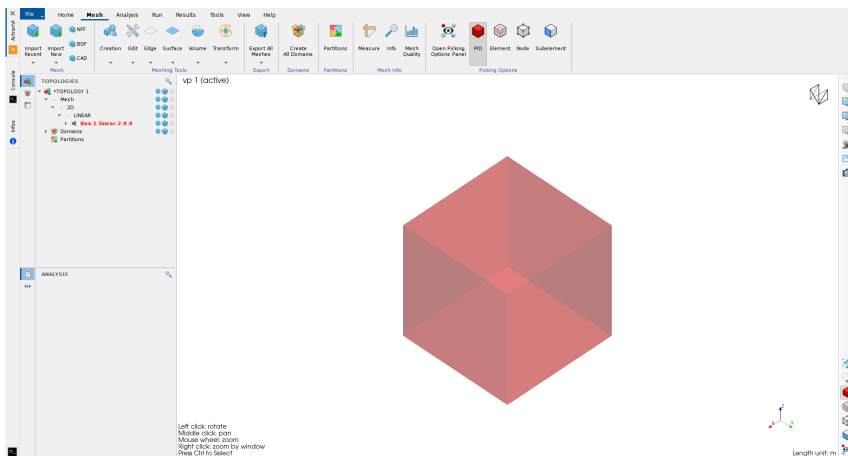

Figure 12.2: PID (element set) selection mode. The PID selection mode icon is selected

12.1.2 Element selection mode

1. Elements can be selected by picking (Ctrl + left click) in the render window. The element selection mode should be the active one
2. The selected elements are respectively colored in orange, green, light blue or pink for 3D, 2D, 1D, or 0D dimension elements

- Turning off the visibility of an element set from the data tree removes every element of this element set from the current selection (if these elements were in the current selection). If the current selection contains other elements belonging to other element sets, these remain selected

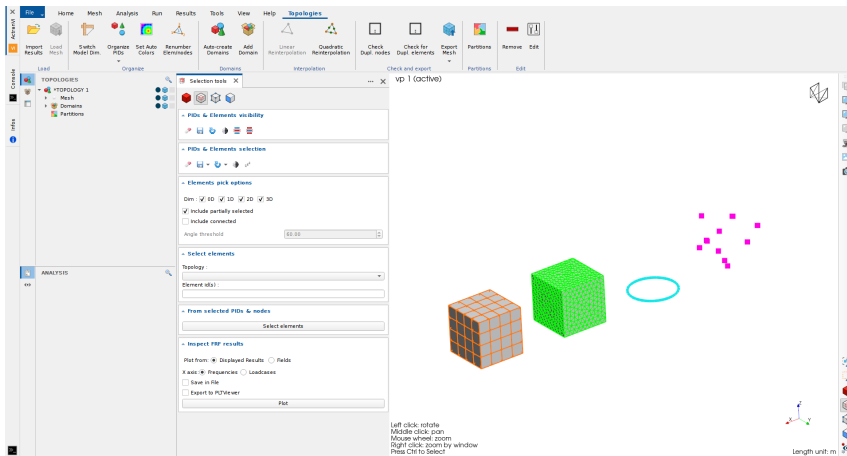

Figure 12.3: Element selection mode. The element selection mode icon is selected

12.1.3 Node selection mode

- Nodes can be selected by picking (Ctrl + left click) in the render window. The node selection mode should be the active one
- The selected nodes are colored in blue
- Turning off the visibility of an element set from the data tree removes every node of this element set from the current selection (if these nodes were in the current selection). If the current selection contains other nodes belonging to other element sets, these remain selected

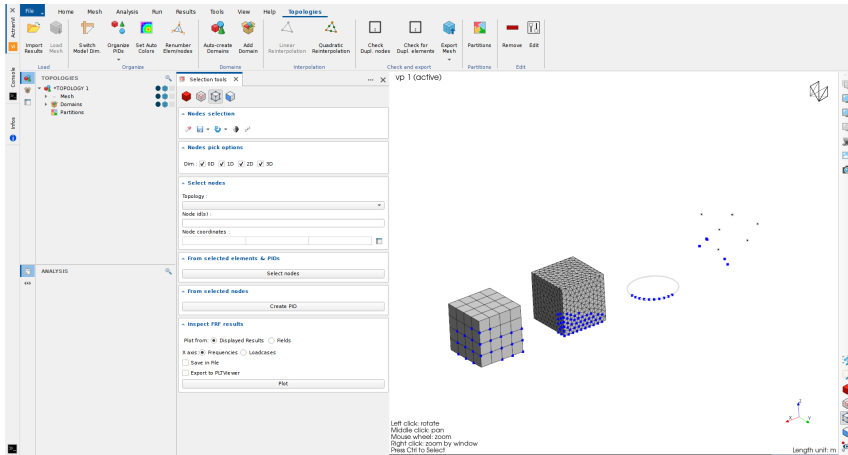

Figure 12.4: Node selection mode. The node selection mode icon is selected

12.1.4 SubElement selection mode

The SubElements selection allows to create new surface or edge elements based on free faces or free edges of surface or volume elements. This can be used to quickly generate a surface to specify a boundary condition for instance.

1. Free surface or edge elements can be selected by picking (Ctrl + left click) in the render window. The subelement selection mode should be the active one
2. The selected new elements are colored in blue
3. Any modification in selection mode unselects the current selection
4. The current selection can be used to create a new element set from the selection panel

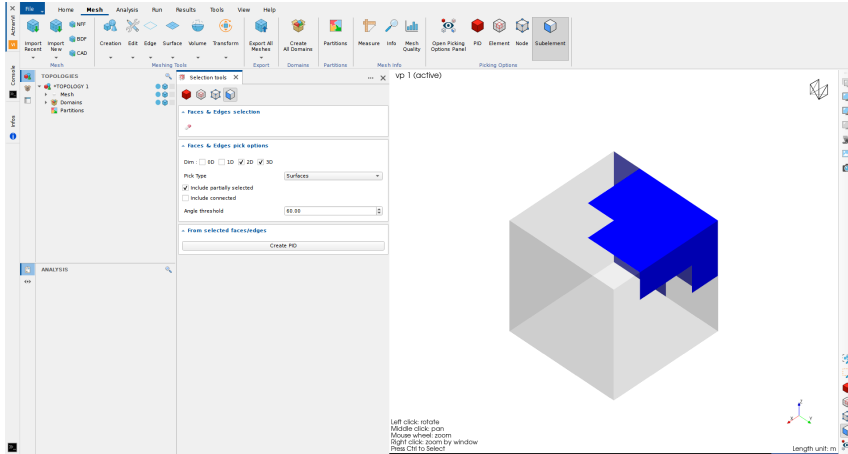

Figure 12.5: SubElement selection mode.

12.2 Picking options panel

The picking options panel contains various options related to the selection, and is located on the right side of the data tree panel (Figure 12.6). This panel is hidden when ACTRANVI is started. The user can show it using Mesh → Picking Options → Open Picking Options Panel, or by using the toggle button "Open Picking Options Panel" in the icon bar in the right side of the render window.

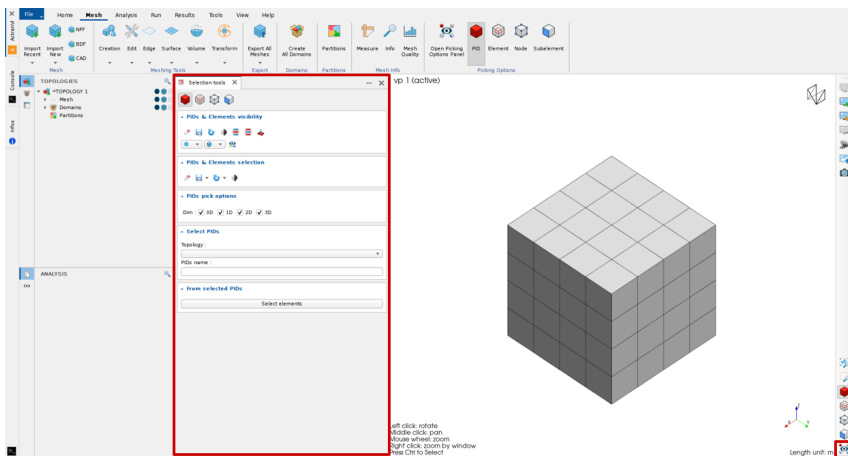

Figure 12.6: Selection tools

The content of the picking options panel changes according to the active selection

mode. A part of the options are shared between several selection modes while other options are only available for a particular selection mode, as described in the following sections.

12.2.1 Tools shared by PID and element selection modes

The "PIDs & Elements visibility" tools are common to PID and element selection modes. These tools can be used to hide/show elements of one (or multiple) elements set(s) that are on the current selection.



Figure 12.7: PIDs & Elements visibility

From left to right:

- Show all elements : restore the visibility of all hidden elements
- Save current elements display state
- Restore previously saved elements display state
- Inverse shown/hidden elements
- Hide selected elements : hide elements of the current selection (selected through PID or element selection)
- Show only selected elements : show only elements of the current selection (selected through PID or element selection)
- Show user normals on selected 2D PIDs (selected through PID selection)

The "PIDs & Elements selection" tools are also common to PID and element selection modes. These tools can be used to operate on the PIDs and the elements of the current selection (not on the nodes of the current selection).

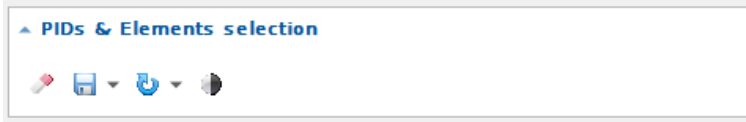

Figure 12.8: PIDs & Elements selection

From left to right:

- Clear the selection : removes the PIDs and elements from the current selection
- Save current selection : saves the PIDs and elements of the current selection
- Restore saved selection : replaces the current selection by previously saved PID and elements (warning : the current selection is lost)
- Inverse selection : replaces the current selection by the unselected PID and elements

12.2.2 PID selection options

In this section, the options specific to the PID selection mode are detailed.

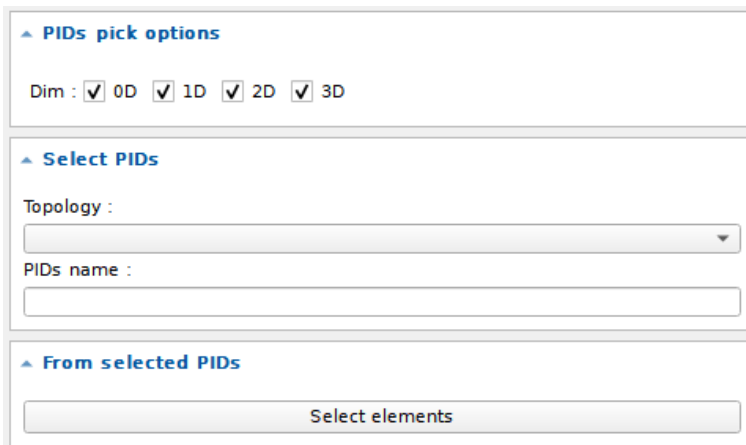

Figure 12.9: PID selection options

1. Dimension restriction : only element sets with specified dimension(s) can be selected

2. Selection by name : if an element set of the specified topology contains the string specified in the name field, it is added to the current selection
3. Selection from selected PIDs: Adds every element of the selected PIDs to the element selection

12.2.3 Element selection options

Some options are specific to the element selection mode.

Figure 12.10: Element selection options

1. Dimension restriction : only elements of specified dimension(s) can be selected
2. With the "Include partially selected" option activated, the area selection will also add to the current selection elements that are partially contained in the

selection area (partially means elements that contain at least one node in the selection area)

3. With the "Include connected option" activated, the selection will add all element(s) that are connected to the selected element(s) with an angle smaller than the "Angle threshold" parameter
4. Selection by IDs : if some elements of the specified topology correspond to the specified element ID(s), these elements are added to the current selection
5. Selection from selected PIDs : adds to the current selection every element contained in the PIDs of the current selection
6. Get FRF from node selected: If results are loaded on a mesh and an element is selected, this tool can be used to obtain the value of the loaded field at the selected element location

12.2.4 Node selection options

Some options are specific to the node selection mode.

Nodes pick options

Dim : 0D 1D 2D 3D

Select nodes

Topology :

Node id(s) :

Node coordinates :

From selected elements & PIDs

From selected nodes

Inspect FRF results

Plot from: Displayed Results Fields

X axis: Frequencies Loadcases

Save in File

Export to PLTViewer

Figure 12.11: Node selection options

1. Dimension restriction : only nodes belonging to elements of specified dimension(s) can be selected
2. Selection by IDs : if some nodes of the specified topology correspond to the specified node ID(s), these nodes are added to the current selection
3. Selection by coordinates: the node closest to the specified location (coordinates) is added to the current selection
4. Selection from selected elements: adds to the current selection every nodes contained in the elements of the current selection
5. Create PID from nodes selected: Create one 0D element set based on the current node selection

6. Get FRF from node selected: If results are loaded on a mesh and a node is selected, this tool can be used to obtain the value of the loaded field at the selected node location

12.2.5 SubElements selection options

Some options are specific to the subelements selection mode.

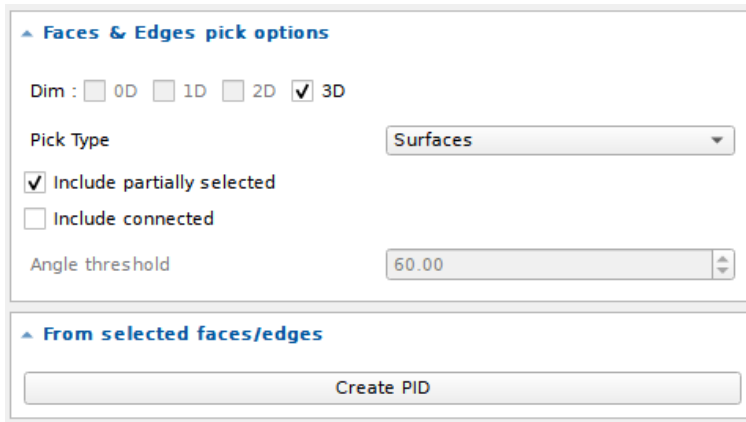

Figure 12.12: Subelements selection options

1. Dimension restriction : only free faces or edges located on surface or volume elements can be selected
2. With the "Include partially selected" option activated, the area selection will also add to the current selection elements that are partially contained in the selection area (partially means elements that contain at least one node in the selection area)
3. With the "Include connected option" activated, the selection will add all free surface element(s) that are connected to the selected element(s) with an angle smaller than the "Angle threshold" parameter

Finally, the current selection can be used to generate a new element set.

ActranVI Meshing tools

13.1 Meshing tools general information

13.1.1 General organisation

Meshing tools can be found in the Mesh → Meshing Tools tab of the ActranVI toolbox.

Meshing tools are spread over 5 categories (Figure 13.1):

- Creation: The Creation category regroups meshing tools to create simple shape meshes
- Edit: The Edit category regroups meshing tools to edit existing meshes
- Surface: The Surface category regroups meshing tools to manipulate surface meshes
- Volume: The Volume category regroups meshing tools to create volume meshes
- Transform: The Transform category regroups meshing tools to apply geometric transformations

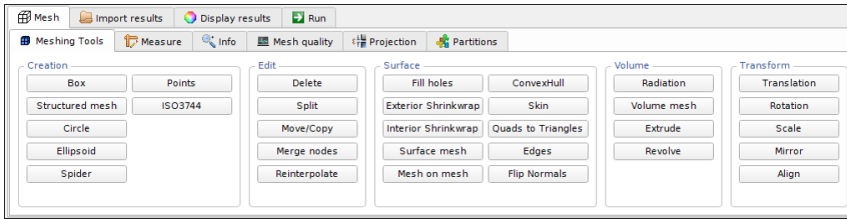

Figure 13.1: Meshing tool global view

When a meshing tool is selected, its parameter panel is displayed (Figure 13.2). It contains:

- The "Back" and "Change tool..." buttons to switch to another meshing tool
- The tool parameters
- A Preview frame where you can find options regarding the interactive preview
- A Save frame where you can find options regarding the final output mesh

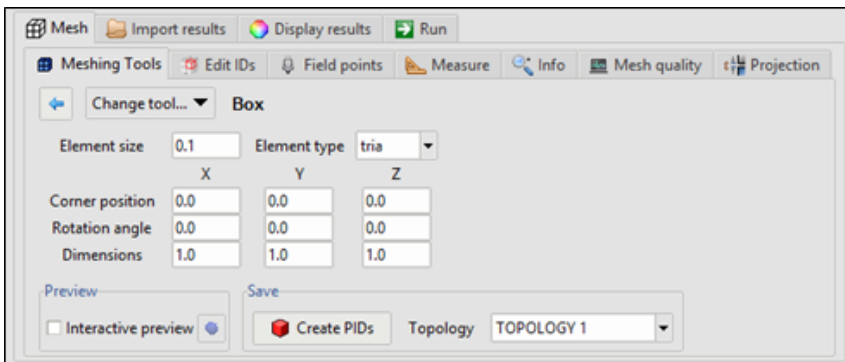

Figure 13.2: Box meshing tool panel

An interactive preview is available for most meshing tools in ActranVI (Figure 13.3). This feature allows to see the mesh created by the meshing tool in the viewport without modifying the Topology. The interactive preview is updated each time a parameter is changed.

1. Activate the interactive preview

2. Switch the interactive preview mesh between opaque or transparent mode
3. Switch whether the original mesh should be hidden or not (not available for all meshing tools)

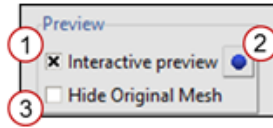

Figure 13.3: Preview frame

13.1.2 Selection for meshing tools

Only element sets (also called PID domains in ActranVI) can be used as input for meshing tools functions (Figure 13.4). For more information regarding the PID selection mode, please refer to the [PID selection mode](#) section:

1. Element sets can be selected by left clicking in the graphical tree
2. Element sets can also be selected by picking (ctrl + left click) in the render window while the PID selection mode is selected.
3. The selected element sets are colored in red in the graphical tree and in the render window
4. The element sets dimension information (0D, 1D, 2D or 3D) is available in the graphical tree

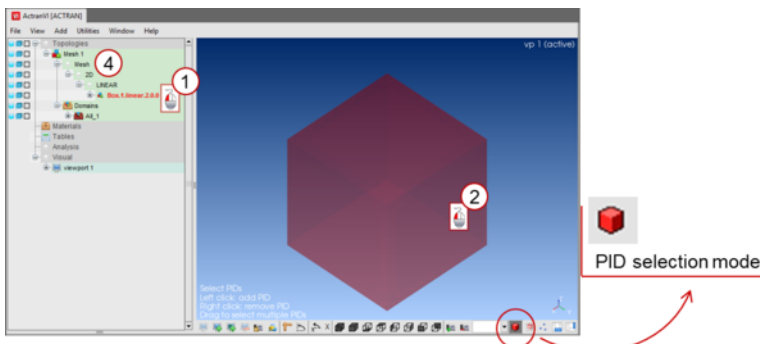

Figure 13.4: Element set selection for meshing tools

To perform meshing operations only on a part of an element set, this part should be selected and placed in a new element set using the PID Assignment toolbox (Figure 13.5) of the **Move or Copy** function.

1. Select the Element selection mode
2. Tick the "Include connected" option (optional)
3. Select a part of an existing element set in the viewport (Ctrl+left mouse button click)
4. Under the Mesh / Meshing Tools tab, go to the Move/Copy function and select Move elements into new PID and specify the name of the new element set
5. Click on "Create PIDs" to create a new element set
6. Meshing operations can be done on this new element set

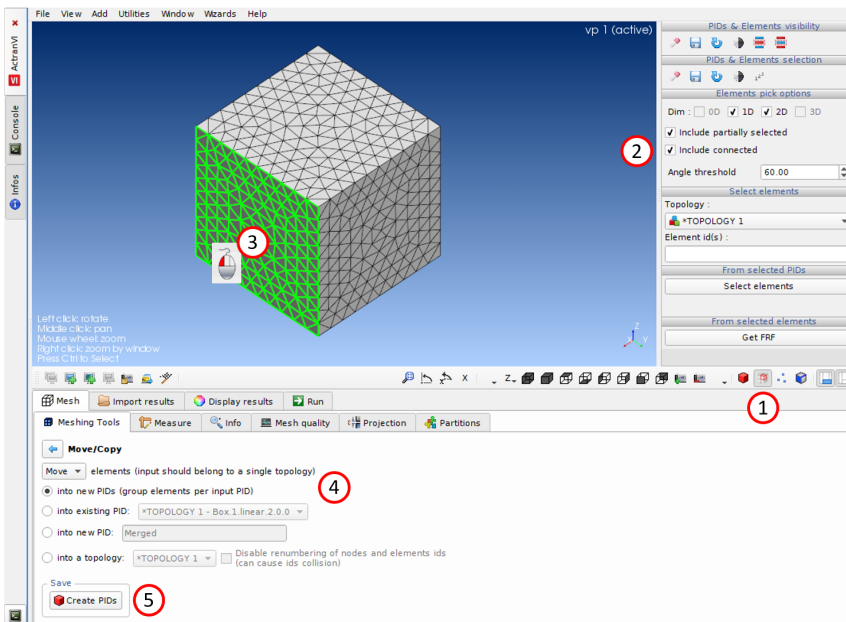

Figure 13.5: Input mesh manipulation for meshing tool input

13.1.3 ActranVI meshing tools workflow

The typical workflow for ActranVI meshing tools is the following

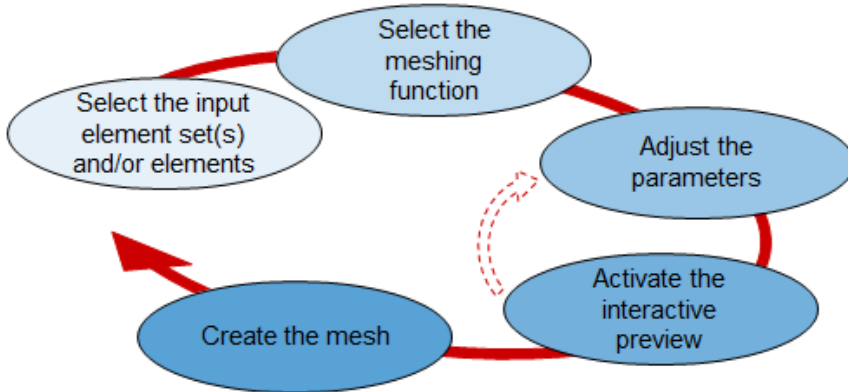

Figure 13.6: Typical workflow for ActranVI meshing tools

1. If the function requires input element set(s), the input element set(s) is (are) selected
2. Go to the meshing function
3. Adjust the parameters
4. Activate the interactive preview and observe the created mesh. Parameters can be adjusted to improve the mesh quality
5. Create the mesh

13.2 Key concepts

13.2.1 Feature Angle

The Feature Angle is the angle above which an edge is considered as a Feature Edge by meshing operations. Feature Edges are edges which geometry is kept during meshing operations.

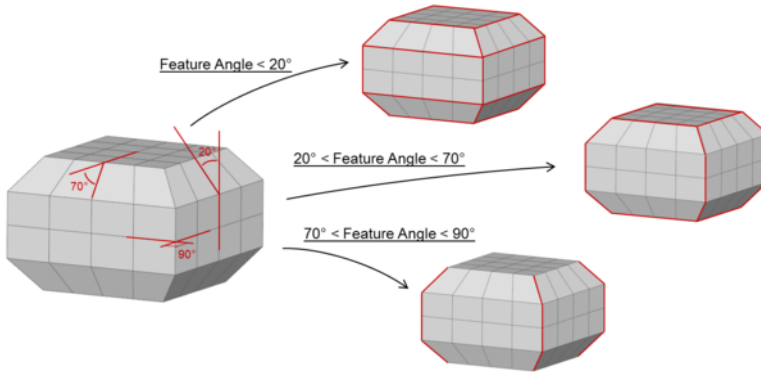

Figure 13.7: Determination of Feature Edges depending on the specified Feature Angle

13.2.2 Gradation

The Gradation is the rate at which element size can grow on a mesh. Values for the Gradation parameter goes from 1 (excluded) to infinity. Having a small gradation generally improves the mesh quality (aspect ratio of created elements).

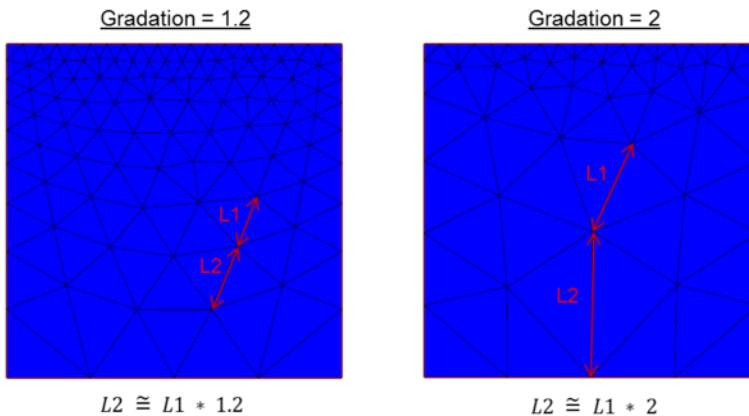

Figure 13.8: Surface mesh creation depending on the specified gradation

Remark. *Gradation also applies for 3D mesh (Volume mesh, Radiation)*

13.2.3 Soft / Hard edge

In ActranVI, an edge can be considered as soft or hard when being processed by a meshing tool

- If considered soft, the geometry of the edge is kept but this edge may be re-meshed
- If considered hard, the geometry of the edges is kept as well as all nodes located on this edge

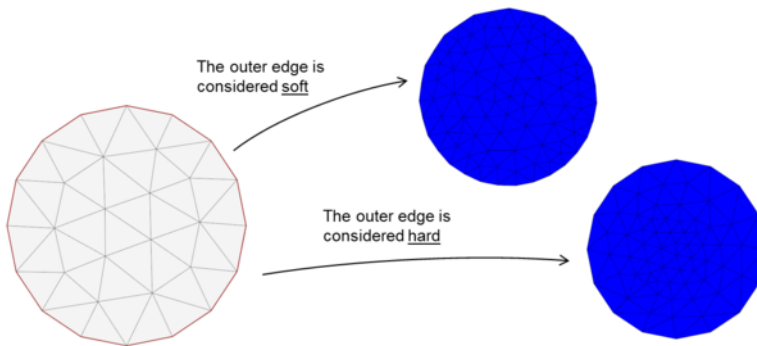

Figure 13.9: Influence of considering edges soft or hard for remesh operation

13.3 Creation tools

13.3.1 The Box function

The Box function creates a box surface element set, containing quadrangles or triangles elements.

The position and orientation relative to the global coordinate system is set through Corner position and Rotation angle parameters.

Dimensions of the box and target element size is set using Element size and Dimensions parameters.

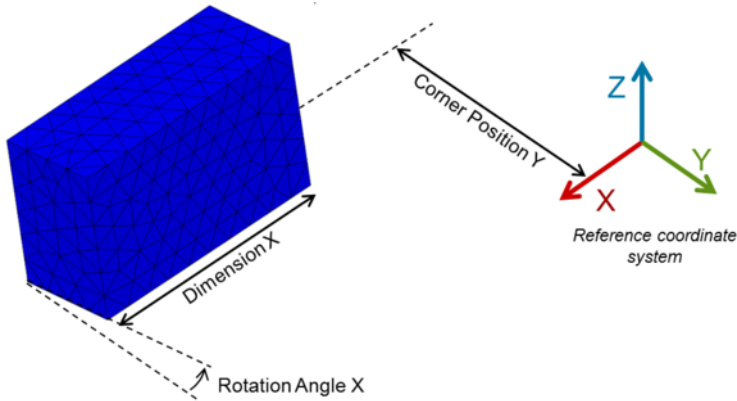

Figure 13.10: Box surface definition using the Box function

Remark. *The rotation specified through the Rotation angle parameter is done around the corner defined through the Corner position parameter.*

Remark. *Specifying one dimension to 0 allows to create a 2D plate (made of quadrangles or triangles elements)*

13.3.2 The Structured Mesh function

The Structured Mesh function creates either:

- A 3D structured box element set
- A 2D plate element set if one direction of the Size parameter is equal to zero
- A 1D line element set if two directions of the Size parameter are equal to zero
- A 0D point element set if the three directions of the Size parameter are equal to zero

The position and orientation relative to the global coordinate system is set through Corner position and Rotation angle parameters.

Dimensions of the box and element size on each of the directions is set using Subdivisions and Size parameters.

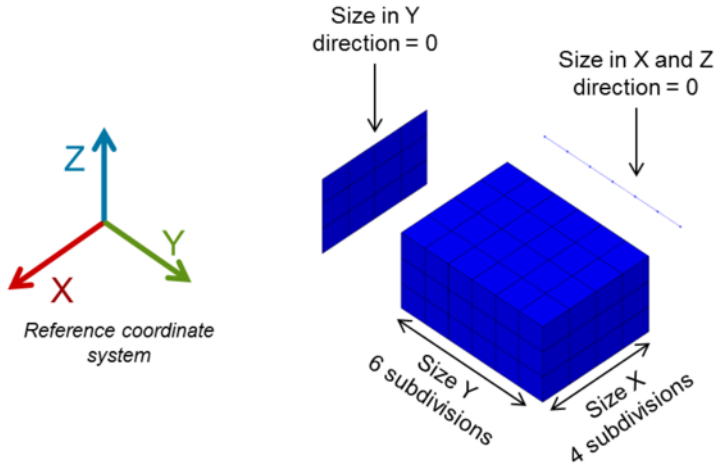

Figure 13.11: Structured mesh definition using the Structured Mesh function

13.3.3 The Circle function

Two types of geometries are available within the Circle function: Circle or Ellipse description.

Within the Circle description, the user must only specify one single radius corresponding to the circle radius. In the Ellipse description, first and second radius (also called major and minor radius) of the ellipse should be entered. By default, the first radius corresponds to the size of the ellipse in the X direction and the second radius in the Y direction.

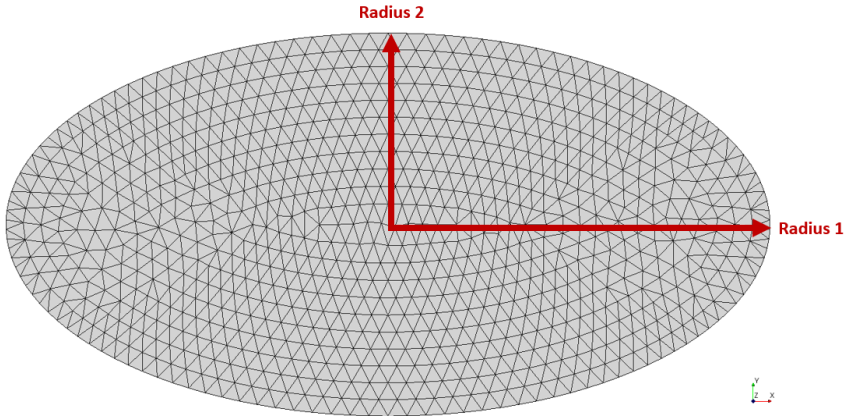

Figure 13.12: Ellipse Definition

In both descriptions, the user can create either:

- A 1D circle/ellipse element set when Angle is 360 and Fill is None
- A 1D arc (of circle/ellipse) element set when Angle is < 360 and Fill is None
- A 2D disk/ellipse element set when Angle is 360 and Fill is "quad", "tria" or "structured"
- A 2D sector (of circle/ellipse) element set when Angle is < 360 and Fill is "quad", "tria" or "structured"

The position and orientation relative to the global coordinate system is set through Center position and Rotation angle parameters.

The target element size is set through the Element size parameter.

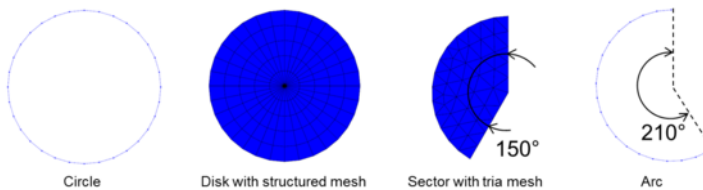

Figure 13.13: Circle, Disk, Sector and Arc definition using the Circle function

Remark. *By default the circle/arc/disk/sector is created on the XY plane.*

13.3.4 The Ellipsoid function

The Ellipsoid function creates a 2D full, half, quarter or eighth ellipsoid element set containing triangles and/or quadrangles elements.

The position and orientation relative to the global coordinate system is set through Center position and Rotation angle parameters.

The dimensions along the three principal axes are defined through the Dimensions parameter.

The Baffles parameter triggers the creation of the mesh on the baffles

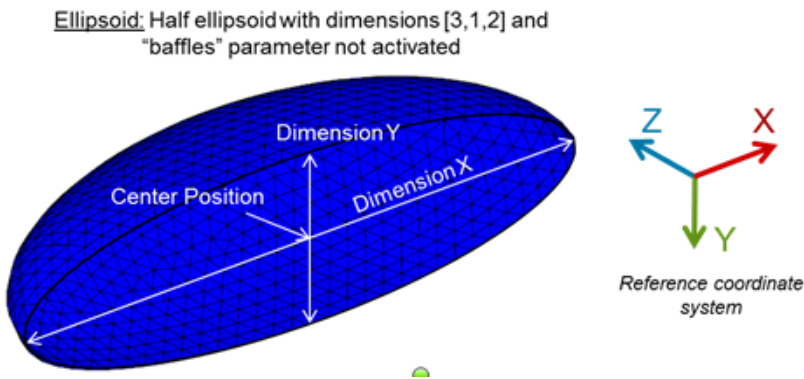

Figure 13.14: Ellipsoid definition using the Ellipsoid function

13.3.5 The Points function

The Points tool is used to create 0D nodes that can be used as field points for the analysis. Four methods are available, they are:

- Cartesian method: to create a straight line of field points, as shown in Figure 13.15 ;
- Polar method: to create a circular arc of field points, as shown in Figure 13.16;
- Custom method: to create field point(s) with user given coordinates;
- Field points from file: to create field points from a text file containing points ID and coordinates;
- Cloud method: to create an ellipsoid or a box cloud composed of field points by specifying the number of layer of points inside the cloud and the

number of points by layer. The cloud dimensions are set with the same methods than the [Ellipsoid](#) and the [Box](#) functions.

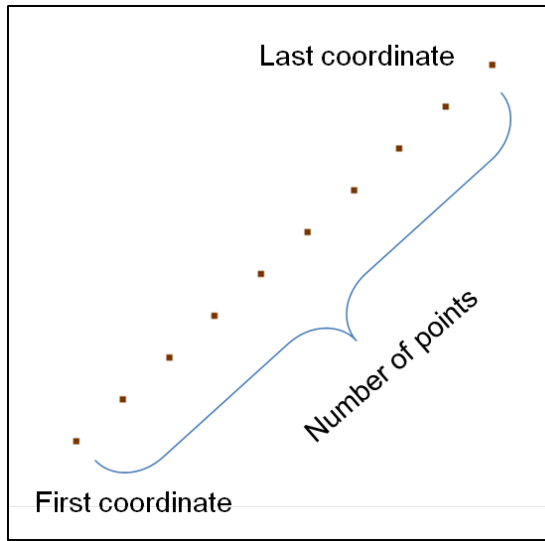

Figure 13.15: Creating field points using Cartesian method

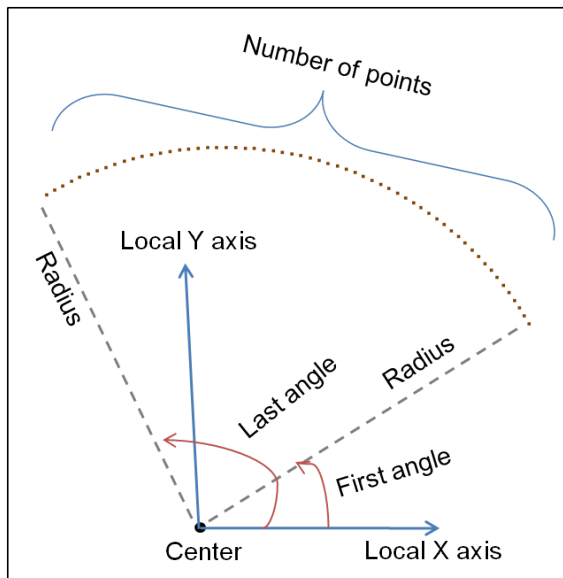

Figure 13.16: Creating field points using Polar method

The created domain can either just be used in other meshing tools, or be added directly to the current analysis. Selecting "Field points" or "Microphones" associates the created Domain into the scope of the "Field Points" or "Microphones" of the active analysis.

For more information on the field points, please refer to ACTRAN User's Guide, Section 10.4 of Volume 2.

13.4 Edit tools

13.4.1 Delete function

The Delete function simply allows to delete a selection of elements or PIDs.

13.4.2 Split function

The Split function divides the selection:

- by connection, into coherent convex parts. In addition, T junctions within the element selection can be split as well.
- by size (number of elements), into multiple PID domains.
 - **across input PIDs** is selected: all PIDs with the same dimension are merged into 1 PID before splitting. As the results, a created PID can contain elements from several input PIDs.
 - **across input PIDs** is not selected: the split is performed separately for each PIDs. A new PID contains only the elements from one input PID.

13.4.3 Move or Copy function

The Move or Copy function contains a set of tools to manipulate a selection of elements or PIDs belonging to a single topology. For all operations, one can select to copy or move the selection using the following options:

- Into a new PID, in which all elements are merged. In this case, all elements should belong to the same dimension and interpolation;
- Into new PIDs, where input elements are kept separated by their input identification;
- Into an existing PID. In this case, all elements should belong to the same dimension and interpolation, which should be the same as the existing PID;
- Into a new or existing topology.

When copying a selection of elements or PIDs, they can be converted directly to a 0D PID by activating the corresponding option.

13.4.4 The Merge nodes function

The Merge nodes function merges nodes of input PID domains if the distance between the nodes is smaller than the Distance parameter.

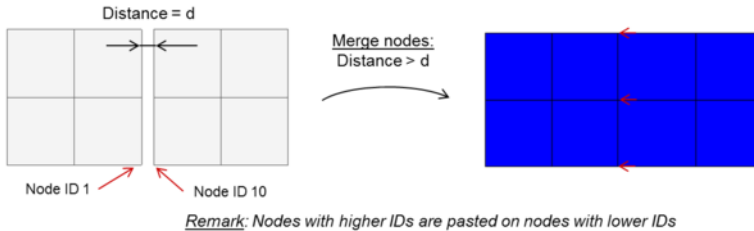

Figure 13.17: Merge nodes separated by a small distance using the Merge nodes function

If the Merge nodes function leads elements to collapse, these elements are deleted

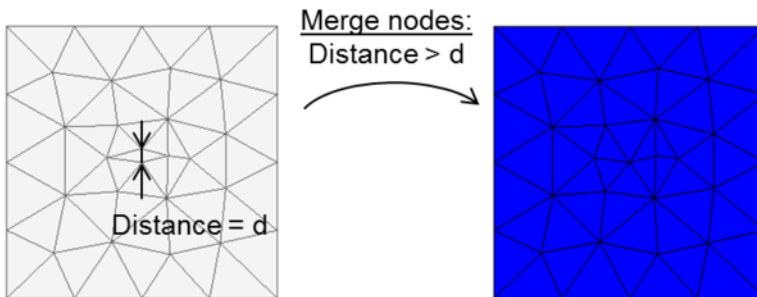
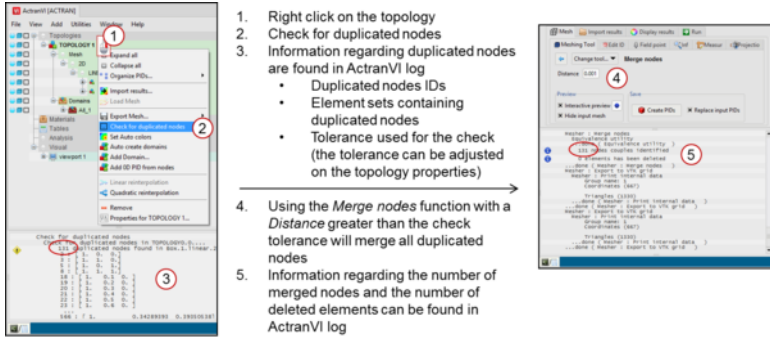

Figure 13.18: Collapsed element are deleted after using the Merge nodes function

The Merge nodes function allows to discard unwanted duplicated nodes. Duplicated nodes can be detected using the Check for duplicated nodes option of the topology.



1. Right click on the topology
2. Check for duplicated nodes
3. Information regarding duplicated nodes are found in ActranVI log
 - Duplicated nodes IDs
 - Element sets containing duplicated nodes
 - Tolerance used for the check (the tolerance can be adjusted on the topology properties)
4. Using the Merge nodes function with a Distance greater than the check tolerance will merge all duplicated nodes
5. Information regarding the number of merged nodes and the number of deleted elements can be found in ActranVI log

Figure 13.19: Combined use of Check for duplicated nodes and Merge nodes function to merge duplicated nodes

13.4.5 The Reinterpolate function

The Reinterpolate function changes the interpolation of the input elements to Linear or Quadratic depending on the specified target interpolation

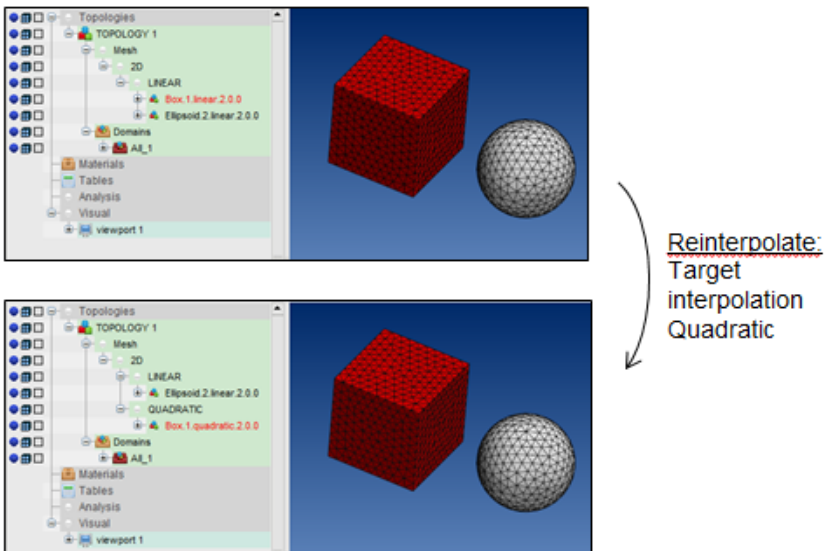

Figure 13.20: Use of the Reinterpolate function to change the interpolation order of an element set

13.5 Edge tools

13.5.1 The Edges function

The Edges function creates a 1D element set containing bar elements. The output mesh consists of the original edges linked with new edges.

The Connection Type controls the element size on the new edges:

- Direct : the new edges contains only one element
- Custom edge size : the element size on the new edges is equal to the specified Element size parameter
- Auto edge size : the element size on the new edges is driven by the size of the elements from which the junction points belong to and the Gradation parameter

In addition, the Sort by node ID option allows to follow the external numbering rather than the closest distance to connect by edged.

The algorithm accepts either 0D or 1D entities. When handling 1D entities as input, the algorithm will try to close edge loops. When providing 0D entities, the provided 1D elements will not be closed. This is then used to connect 2 or more points together, following their external numbering or distance.

The algorithm detects every available junction points and links it to the closest other junction point:

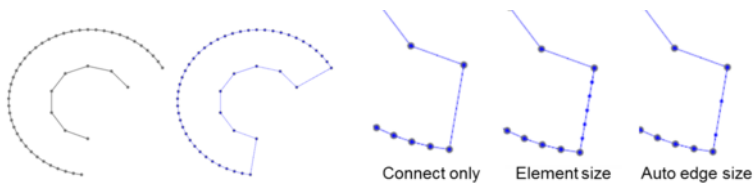

Figure 13.21: Create 1D elements to close an edge using the Edges function

13.5.2 The Spider function

The Spider function creates a 1D element set containing bar elements which all connect each individual node provided to a central node, generating a spider element. These spider elements can directly be used as a mean constraint or rigid body elements.

The master node of the spider element can be chosen:

- Center: Default behavior. The master node is generated at the geometrical center of all selected nodes or PIDs.
- Position: The geometrical position of the master node is explicitly defined by the user.
- Id: A Node Id can be provided as master node, which will directly link the spider element with this latest.

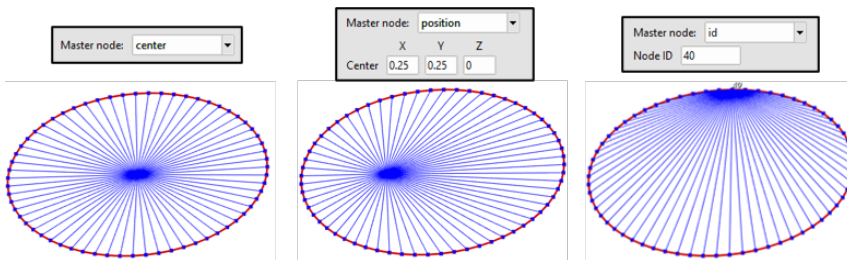

Figure 13.22: Different options of master node for the Spider tool

13.5.3 The Remesh edges function

The Remesh edges function allows to remesh existing 1D PIDs while keeping grids attached to other PIDs as fixed. This can be used to refine or coarsen existing 1D PIDs while keeping the shape in case of corners and chamfers. Four options are available:

- The Element size is the maximum edge size the function should return.
- The Feature angle defines the angle between edges in the original mesh above which the grid will be assumed to be fixed. The feature angle might not be respected in the output mesh.
- The Minimum feature size specifies a length below which edges will not be considered as a feature. This insures not to account for tiny elements. By default, this is set to 0.
- The Chordal distance is the maximum distance with respect to the original mesh, which can enable local refinements of the meshes in order to insure curvatures are correctly respected.

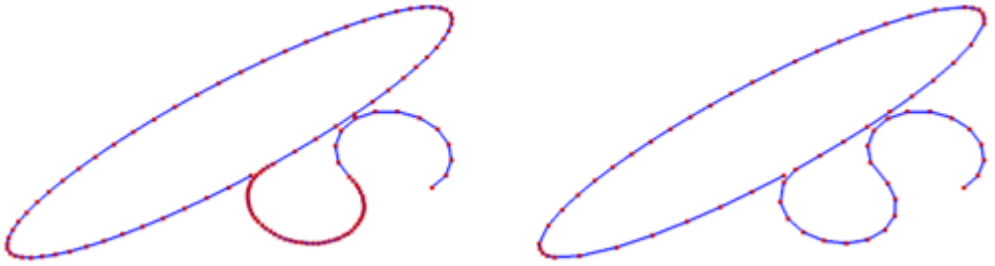

Figure 13.23: Remeshing of existing edges accounting for feature edge and chordal distance, with local refinement

13.6 Surface tools

13.6.1 The Fill Holes function

The Fill Holes function allows to fill holes in 3D or closed 2D element sets. The created 2D element set contains the triangles elements that fill the detected holes. Holes detection is controlled by a maximum diameter parameter and a feature edge parameter.

Holes with a diameter bigger than Max Hole Diameter won't be filled.

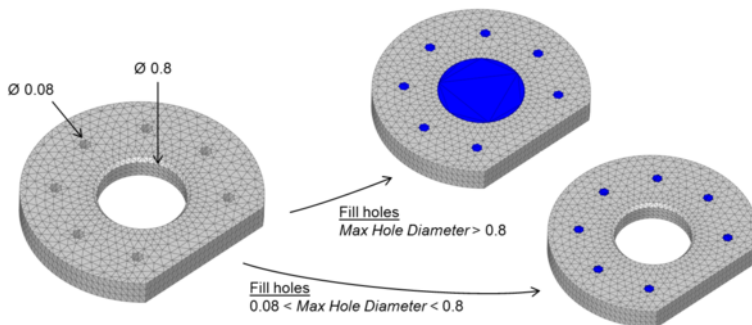

Figure 13.24: Fill holes: The Max hole diameter parameter

The Feature Angle parameter controls which edges can define a hole. If the element edge angle is higher than the Feature Angle value, then it can define a hole.

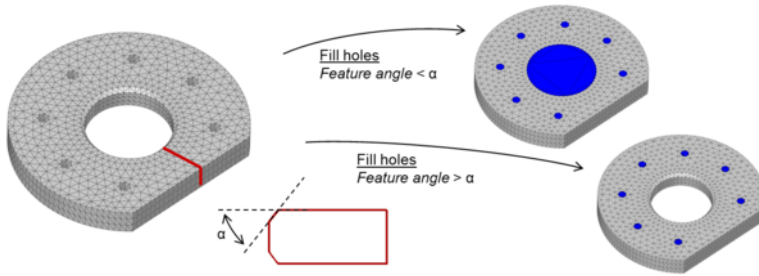

Figure 13.25: Fill holes: The Feature angle parameter

The Mode parameter controls the way the holes will be filled:

- Fast : fills the holes using the fewest elements possible
- Boundaries : fills the holes with the same element size as the holes boundaries elements
- Custom : fills the holes with a target element size driven by the Element size parameter

Remark. *If a 2D surface contains openings, the Fill Holes function may fill these openings but is not always able to detect and fill them. To fill openings on a 2D surface, the [Surface mesh](#) function should be preferred.*

13.6.2 The Exterior Shrinkwrap function

The Exterior Shrinkwrap function creates a 2D element set that wraps the input element sets.

The element size is driven by the Shrink element size parameter.

The distance between the shrinkwrap surface and the input mesh is set by the Distance parameter.

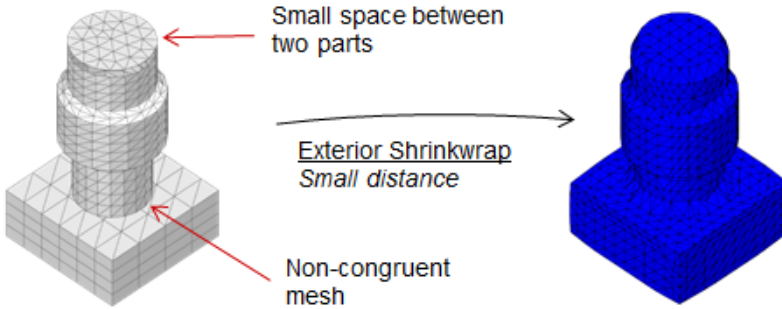

Figure 13.26: Use of the Exterior Shrinkwrap function to obtain a closed surface around a part

Remark. When the Distance parameter is set to 0, the smallest possible distance (Topology mesh tolerance) will be used.

13.6.3 The Interior Shrinkwrap function

The Interior Shrinkwrap function creates 2D element sets that wrap the interior of input 2D and 3D element sets. If the input selection contains 3D element sets the skin of these element sets will be considered.

The element size is driven by the Shrink element size parameter.

The distance between the shrinkwrap surface and the input mesh is set by the Distance parameter.



Figure 13.27: Use of the Interior Shrinkwrap function to obtain a closed surface inside a part

Remark. When the Distance parameter is set to 0, the smallest possible distance (Topology mesh tolerance) will be used.

The Minimum Cavity Volume parameter is used to prevent the Interior

Shrinkwrap function from outputting unwanted small cavities. All cavities with a volume smaller than the specified value will be discarded

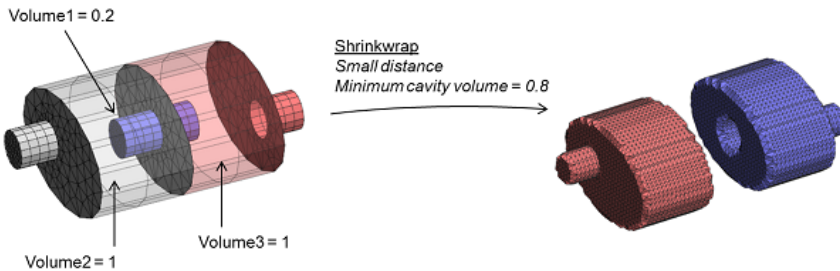

Figure 13.28: Use of the minimal cavity volume parameter to filter the output of the Interior Shrinkwrap function

Remark. *The volume of each detected cavity is not computed on the final mesh output by the function. Some small differences in volume can therefore be observed between the value entered for the parameter and the volume of the created cavity*

13.6.4 The Surface mesh function

The [Surface mesh](#) function creates a 2D element set based on a set of edges. If 2D element sets are provided as input, the skin of these surfaces will be used

The Surface fill method parameter allows to choose the desired algorithm to create the surface mesh:

- Fast (Default) algorithm will perform a simple tessellation
- Fitted will apply a Mesh on Mesh on top of the Fast tessellation. The Element size parameter drives the target element size of the create mesh
- Planar will use a surface filling algorithm with gradation control providing better mesh quality but only works to create planar surface. The Element size parameter drives the target element size of the create mesh and the Gradation factor parameter controls how fast element size can grow on the created mesh

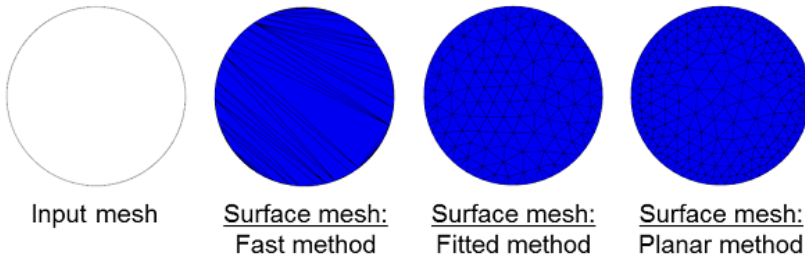

Figure 13.29: Surface mesh filling methods

The Group by edge loop parameter drives the way the [Surface mesh](#) considers the input mesh when it contains several edge loops:

- If the Group by edge loop parameter is not activated, the [Surface mesh](#) function will create one surface between all edge loops. If the Planar fill method is selected the median plane is calculated and the edges are connected to this plane
- If the Group by edge loop parameter is activated, each edge loop is filled independently

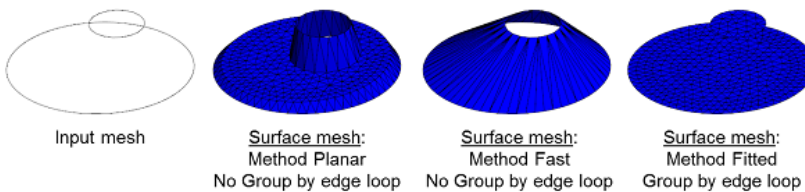

Figure 13.30: Surface mesh: The Group by edge loop parameter

If every edge loop is on the same plane and one edge loop includes the others, the [Surface mesh](#) function with planar method creates a surface between the edge loops if the Group by edge loop parameter is not activated

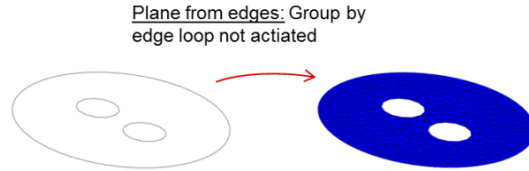

Figure 13.31: Surface mesh: Creating a surface between several edge loops

If the input mesh does not contain closed loops, an implicit [Edges](#) operation is performed to close the edge loop.

13.6.5 The Mesh on Mesh function

The Mesh on Mesh function re-meshes the 2D input element(s) set(s) using the Element size and Element type parameters.

The user has the choice between two meshing methods:

- "Classic" method. This method is used in previous Actran versions as well.
- "Flexible" method. This is proposed as an alternative to the classic meshing tool. It is advised when handling intersections due to the remeshing of very close surfaces and models with a high number of degrees of freedom. Using the "flexible" method, an additional parameter can be defined. This is the chordal distance parameter, a relative value expressed as a percentage of the element size. This parameter multiplied by the element size defines the maximum distance of the new mesh from the original one.

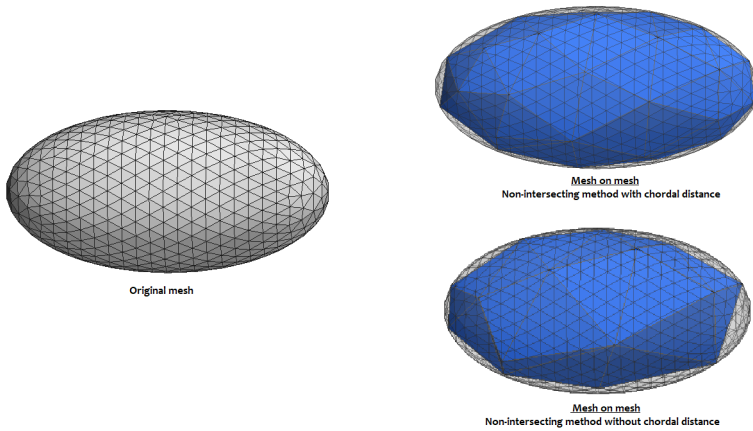

Figure 13.32: Mesh on Mesh: Chordal distance

All parameters presented below are available for both methods.

When the Auto feature recognition is activated, the Angle defeaturing parameter controls which edges will be kept. If the element edge angle is higher than the Angle defeaturing value, then the edge will be kept by the Mesh on Mesh function.

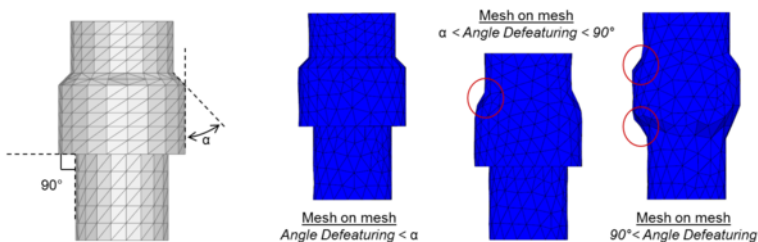

Figure 13.33: Mesh on Mesh: The Angle defeaturing parameter

The Free edges parameter controls how the Mesh on Mesh function will remesh the free edges:

- If "Hard" is selected, the nodes of the free edges are kept in the new mesh.
- If "Soft" is selected, only the geometry of the free edge is kept.

Remark. *If nodes are connected to element sets that are not contained in*

the input selection, the nodes are kept regardless the Free edges parameter definition.

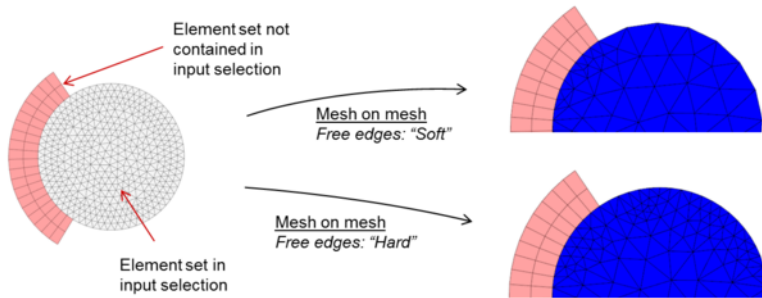

Figure 13.34: Mesh on Mesh: The Free edges parameter

Inner interfaces parameter controls how the interfaces between the several element sets selected will be handled.

- If "Hard" is selected, the nodes and edges length at the interfaces are untouched. No intermediate points are created on the interfaces edges. The Mesh on Mesh output will keep input element sets separated.
- If "Soft" is selected, only the geometry of the edges at the interfaces is kept. This means the edges are remeshed (new points) to match the target Element size parameter. The Mesh on Mesh output will keep input element sets separated.
- If "Merge" is selected, interfaces between element sets in input selection are not taken into account. The Mesh on Mesh output will contain only one element set.

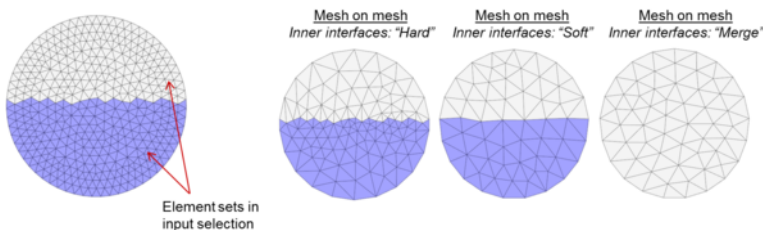

Figure 13.35: Mesh on Mesh: The Inner interfaces parameter

13.6.6 The Convexhull function

The Convexhull function creates a 2D element set corresponding to the convex envelope of all input element sets. The created surface is located at the minimal distance Distance from any input element set.

One or more baffle planes can be defined using the Baffle planes parameter: the created mesh will be bounded by these planes, still remaining a convex surface.

Baffle planes parameter X, Y and Z values (x,y,z) correspond to the X=x, Y=y and Z=z planes.

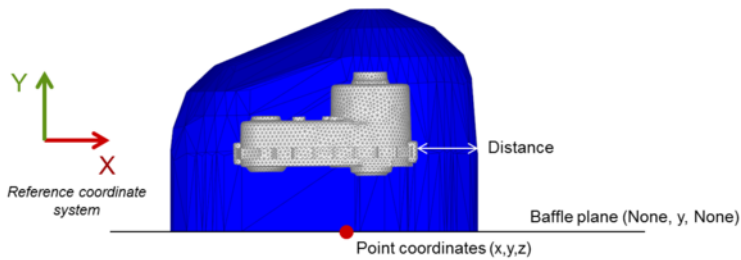

Figure 13.36: Use of the Convexhull function to create a convex surface around a gearbox

13.6.7 The Skin function

The Skin function extracts the skin of the input element sets:

- If the input mesh is 3D, a 2D element set is created
- If the input mesh is a non-closed 2D element set, a 1D element set is created
- If the input mesh is a non-closed 1D element set, a 0D element set is created

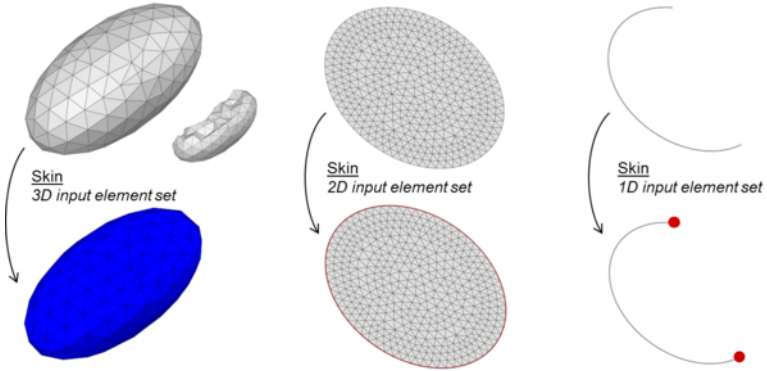

Figure 13.37: Skin: Output mesh depending on input mesh dimension

Interfaces parameter controls how the interfaces between the several element sets selected will be handled.

- If "supress" is selected, the inner interfaces are removed from output mesh.
- If "only" is selected, only the inner interfaces are kept in the output mesh.
- If "keep" is selected, skin around both input element sets is completely kept.

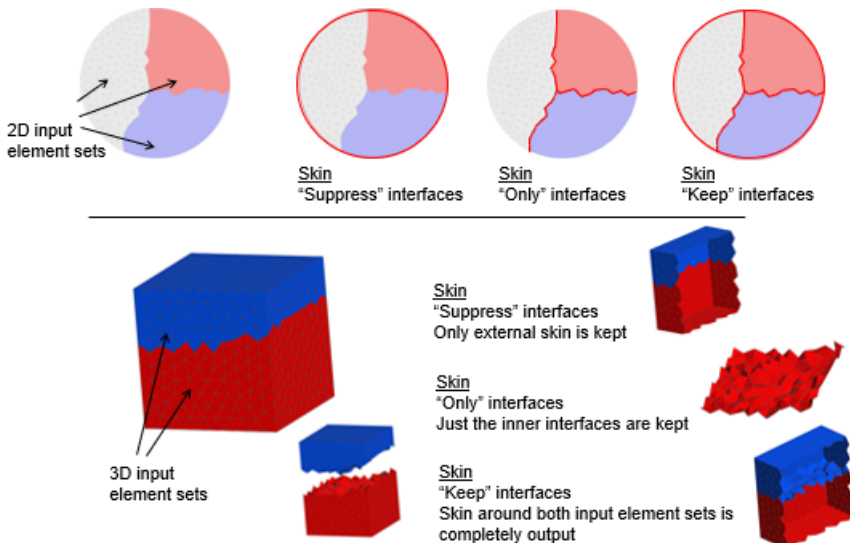

Figure 13.38: Skin: Output mesh depending on interfaces parameter

13.6.8 The Quads to Triangles function

This function creates a 2D mesh containing only triangle elements with the same interpolation order than its input meshes. The output mesh consists in splitting all the quadrangles elements from the input meshes.

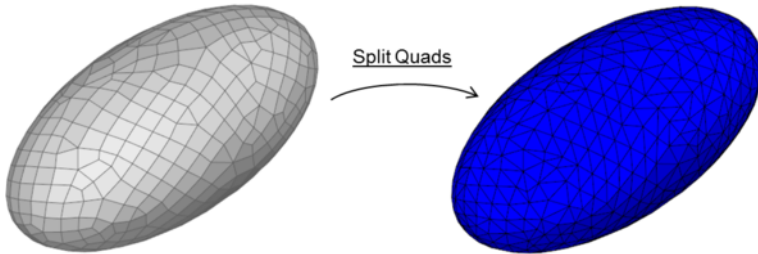

Figure 13.39: Split quadrangle elements to triangle elements on a 2D ellipsoid

Quadrangle elements are split on their shortest diagonal. This provides the best aspect ratio for the created triangle elements.

Remark. *As the [Volume mesh](#) function can only be used on element sets containing only triangle elements, the Quads to Triangles function is often used before performing a [Volume mesh](#).*

13.6.9 The Flip Normals function

The Flip Normals function allows to reverse or regularize the normals of 2D PIDs (or 1D PIDs in 2D topology) selected through PID selection. Three options are available:

- Inverse option: the normals of selected 2D PIDs (or 1D PIDs in 2D topology) are flipped to the opposite direction.
- Inside/Outside options: the normals of closed 2D PIDs (or 1D PIDs in 2D topology) are set to be consistently pointing inward/outward. For non-closed surface(s), these options are used to regularize the normals.

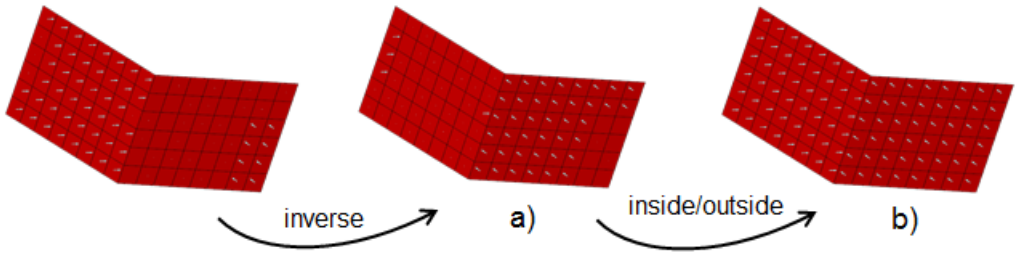

Figure 13.40: a) The normals are reversed. b) The normals are regularized

13.6.10 The Intersection function

The Intersection function enables to identify and create the edges that are at the intersection of different surfaces. The user can choose between two input methods: PID or stored selection. Default method is the PID selection that will perform the intersection between two or multiple 2D PIDs. The stored selection method allows to intersect portion of 2D mesh that were previously selected by the user. The PIDs/selections have to belong to the same topology.

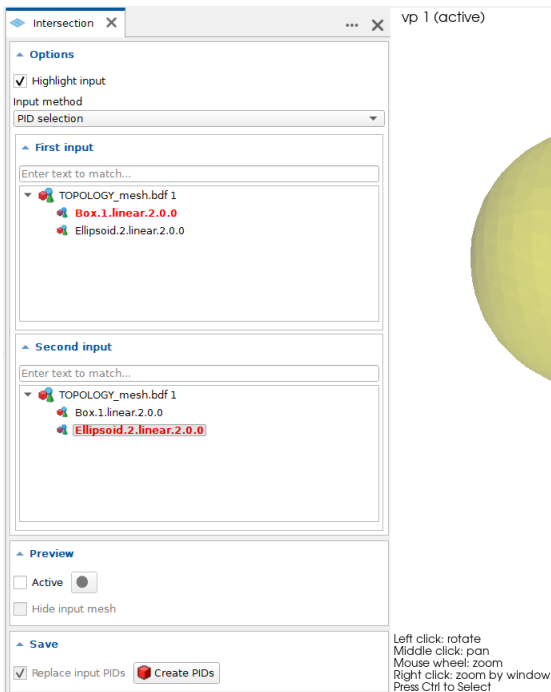

Figure 13.41: Intersection tool with PID selection

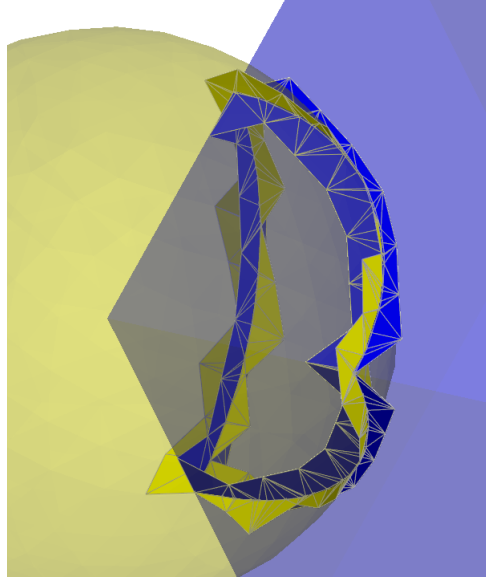

Figure 13.42: Intersection preview

13.7 Volume tools

13.7.1 The Volume mesh function

This function creates one 3D mesh from one or several 2D closed input element sets. The output mesh can consist of tetrahedral, hexahedral and pyramid elements with the same interpolation order than the input mesh(es).

The output mesh element size is driven by the Element size parameter and the Gradation factor parameter. Without the All Cavities option, only one 3D mesh is generated and it is expected the provided surfaces should define a closed surface with or without interior closed surfaces. With the All Cavities option activated, all possible volume definitions will be accounted for and meshed individually. A separate 3D volume mesh will be provided for all individual volume detected. An example of this method is provided in Figure 13.44.

- If Hexacore method is not activated, the volume mesh generated will be filled with tetrahedral elements. There can be pyramid elements in the transition zone if the input surface mesh contains quadrangular elements.
- If Hexacore method is activated, the volume mesh generated will be filled with Cartesian hexahedral elements (aligned with global coordinates system or with the provided orientation vector) in the inside and blended with tetrahedral/pyramid elements in the transition zone to the input surfaces.

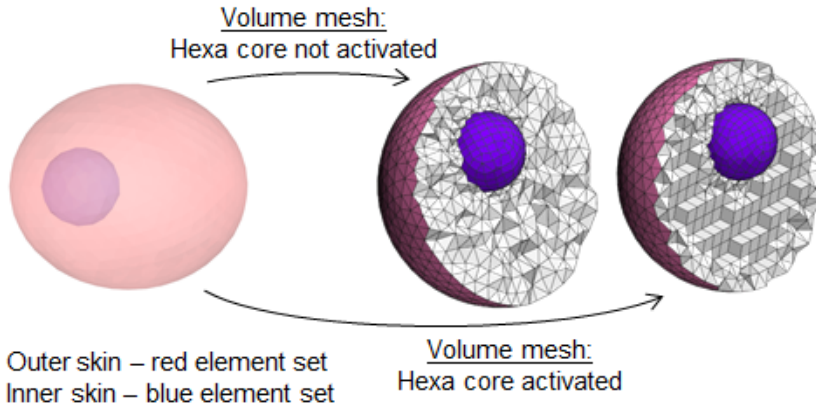

Figure 13.43: Use of the Volume mesh function to create a 3D mesh between two ellipsoids

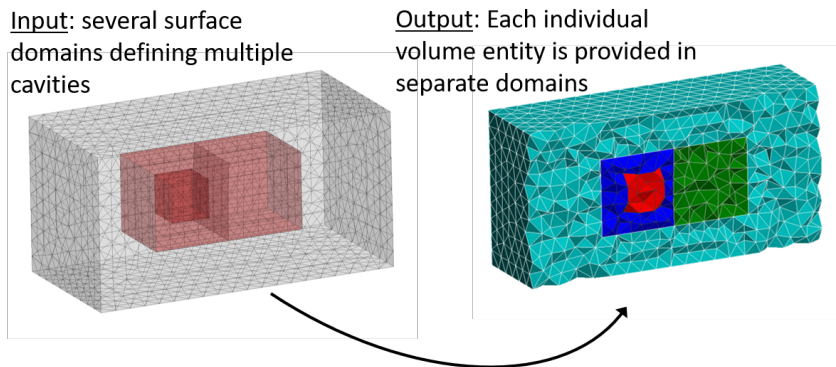

Figure 13.44: Handling of multiple cavities in the Volume mesh tool

13.7.2 The Extrude function

The Extrude function creates a mesh by extruding the input element set(s).

If the input selection contains 2D elements sets, the Extrude tool outputs a 3D element set corresponding to the extruded volume and one (or two) 2D element set(s) corresponding to the extruded surface (and the side surface if the input element sets have free edges).

If the input selection contains 1D elements sets, the Extrude tool outputs a 2D element set corresponding to the extruded surface and one (or two) 1D element set(s) corresponding to the extruded edge (and the side edge if the input element is not a closed edge).

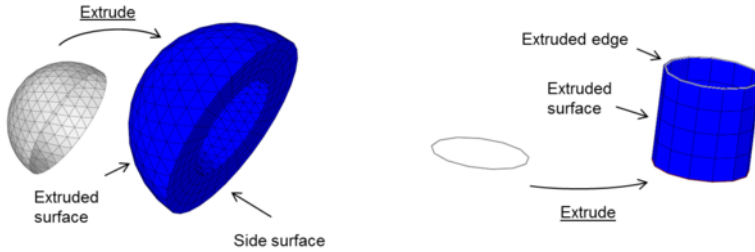

Figure 13.45: Extrude: Output mesh depending on input mesh dimension

The extrusion is done following normal vectors. These vectors can be computed using the different methods below:

- Vertex normal (only available for 2D elements sets input in 3D topologies and 1D elements sets input in 2D topologies): the normal vector of each node is computed based on the normal vectors of surrounding elements. One or more baffle planes can be defined: the normals of nodes on the baffle planes is then modified to match the plane orientation.
- User defined normal: the user defines a normal vector by its three components (X,Y,Z) , which will be the same for all nodes.
- From center: the user defines a center by its three coordinates (X,Y,Z) : the normal for each point is defined by the direction between the center and the node.

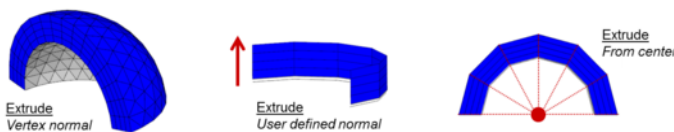

Figure 13.46: Extrude: Output mesh depending on normal method used

13.7.3 The Layers function

The Layers function creates a mesh by extruding the input element set(s), but reconstructs the elements when facing self-intersections and insures a correct element size is produced.

The input selection must contain 2D elements sets, the Layers tool outputs a 3D element set corresponding to the extruded volume and one (or two) 2D element

set(s) corresponding to the extruded surface (and the side surface if the input element sets have free edges).

The extrusion parameters are identical to the Extrude meshing tool. The internal element size can be select as follows

- Free: Chosen by default, the extrusion size will be made as defined and the reconstruction of the elements will have no restrictions in element size.
- Input surface: The local element size of the provided surface will be taken to insure all extruded layers and reconstructed parts corresponds to this element size.
- User defined: Provided element size, both for the extrusion and the reconstruction.

13.7.4 The Revolve function

The Revolve function creates a mesh by revolving the input element set(s).

The revolve total angle is driven by the Angle parameter, and the rotation axis is defined by the Rotation axis origin and Rotation axis vector parameters.

The number of layers is driven by the Steps parameter.

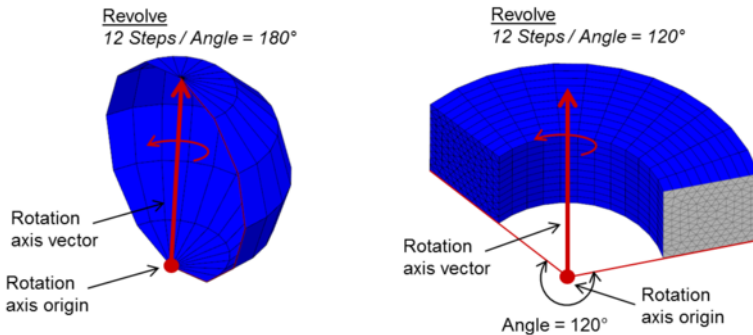

Figure 13.47: Examples of usage for the Revolve function

If the Revolve function is applied with Angle = 360 and the surface located at the end of the rotation coincide with the input mesh, all nodes located at the input mesh location are not duplicated. The created mesh is therefore not cut at the input mesh location.

If nodes are located on the rotation axis they are not duplicated by the Revolve

function.

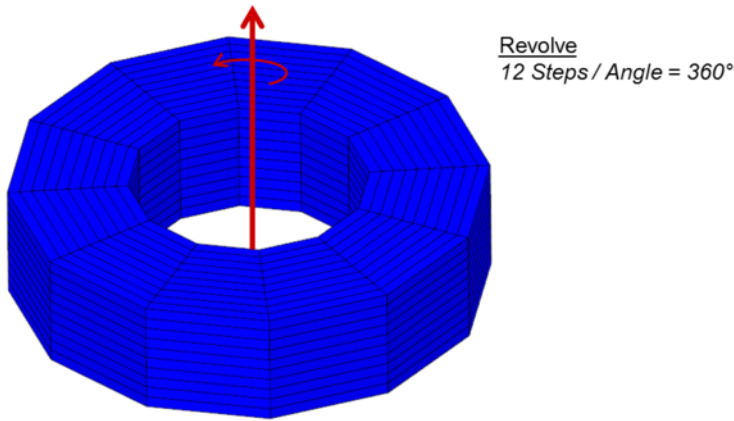

Figure 13.48: Nodes located on the rotation axis or duplicated nodes are merged

13.7.5 The Radiation function

The Radiation function is an "all-in-one" function very useful for automatic mesh generation of acoustic radiation problems. This tool consists in the combination of 4 meshing tools: the [Convex Hull](#), the [Mesh On Mesh](#), the [Surface mesh](#), and the [Volume mesh](#). It works in three steps:

- First a convex hull surface mesh is generated at the distance specified through the Volume thickness parameter. One or more baffle planes can be defined along X, Y, or Z direction : the created surface mesh is then bounded by these planes, still remaining a convex surface.
- The previously created surface is then remeshed by a Mesh On Mesh operation. The surface element size is driven by the Element size parameter.
- If baffle planes were defined, the baffles are created using a Plane from edge operation. The surface element size is driven by the Element size parameter.
- A 3D mesh is created by a Volume mesh operation performed between element sets in input mesh and the convex mesh surface generated by the previous steps. The size of the tetra elements is driven by the Element size and the Gradation factor parameters

This meshing tool creates a 2D mesh corresponding to the convex surface and a 3D mesh corresponding to the volume generated by the Volume mesh operation.

If one or more baffles are defined, 2D meshes corresponding to these baffle surfaces are also created.

The output 2D mesh contains only triangular elements and the output 3D mesh is made up of tetrahedral/hexahedral/pyramid elements, with the same interpolation order as its input mesh(es).

Remark. *If the input mesh is a closed 2D element set, baffle planes cannot intersect the input element set. If the input mesh is an open 2D element set, the free edges must be located on the baffle planes.*

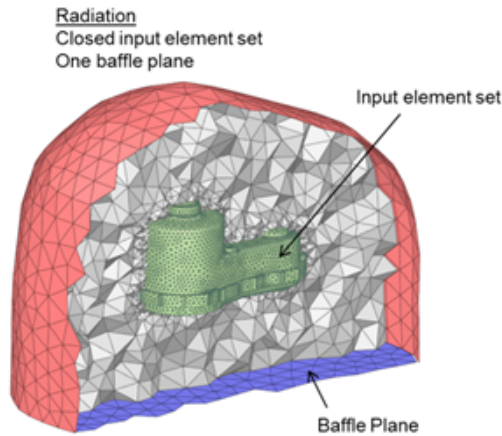

Figure 13.49: Use of the Radiation function on a closed 2D surface mesh with one baffle

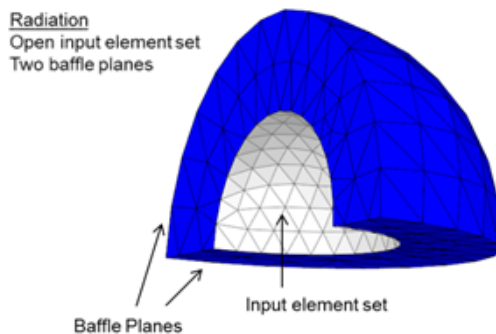

Figure 13.50: Use of the Radiation function on an open 2D surface mesh with two baffles

13.8 Transform tools

13.8.1 The Translate function

The Translate function is used to copy or move input element sets by applying a translation.

The translation operation is done along a vector defined by the Vector and (Scale) Factor parameters.

If the Replace input PIDs is activated, the input element sets are moved. If not, they are copied.

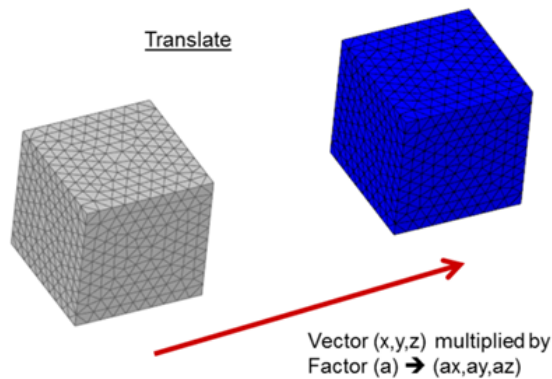

Figure 13.51: Use of the Translate function on a cube mesh

If some element sets in the input mesh share nodes with PID domains not contained in the input mesh, the Move nodes at interfaces parameter specifies if these nodes should be moved (ticked) or remain fixed (unticked)

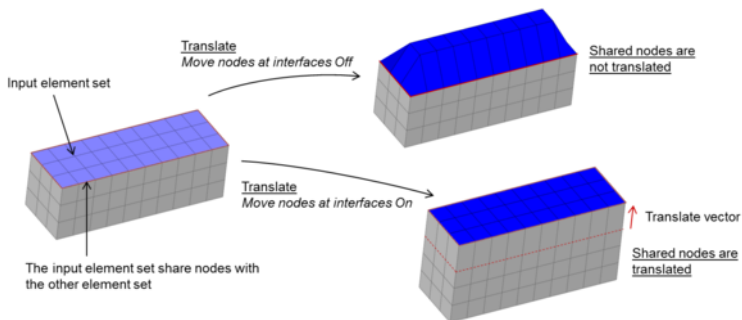

Figure 13.52: Transform tools: the Move nodes at interfaces parameter

13.8.2 The Rotation function

The Rotation function rotates the input meshes using one of the two methods below:

- Rotation around the coordinate system centered on the Origin with angles Rotation angles (in degrees). The rotation sequence is executed in the same order than the coordinate system (X then Y then Z)
- Rotation around a user-defined axis, defined by the Origin and Rotation axes parameters. The rotation angle is specified through the Rotation angle parameter

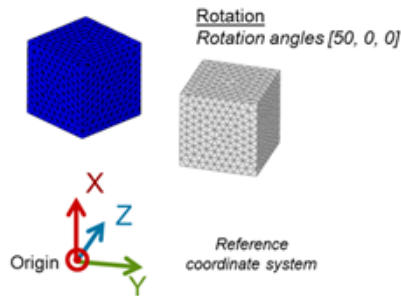

Figure 13.53: Use of the Rotation function on a cube mesh

Remark. For Replace input PIDs and Move nodes at interfaces parameters please refer to function [Translate](#).

13.8.3 The Scale function

The Scale function scales all element sets in input. The scaling is done by translating the nodes of all the input element sets in the following way: the distance from the point defined by the Origin parameter and a particular node is projected on each global axis and multiplied by the Scale factor component corresponding to this axis.

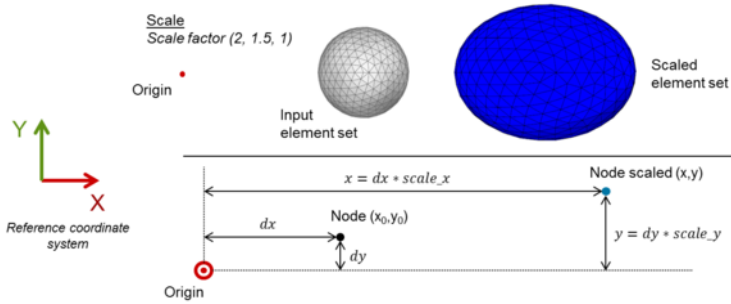

Figure 13.54: Scale function usage

Remark. For Replace input PIDs and Move nodes at interfaces parameters please refer to function [Translate](#).

13.8.4 The Mirror function

The Mirror function creates symmetric mesh with respect to a symmetry plane.

The symmetry plane is defined by three points (Point 1, Point 2 and Point 3 parameters).

All nodes located exactly on the symmetry plane are not duplicated, therefore the input and output element sets are fully connected on the symmetry plane.

If the Merge mirror with input parameter is activated the created mirror mesh will be placed in the same PID as the input mesh.

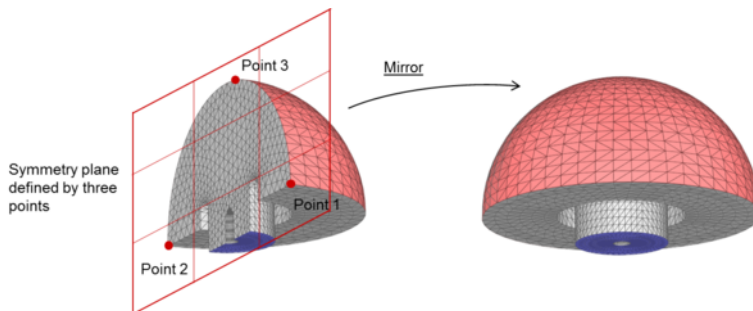

Figure 13.55: Use of the Mirror function to create a full model from a symmetrical model

13.8.5 The Align function

The Align function projects all the nodes of the input element sets on a plane. This plane is defined by three points (Point 1, Point 2, Point 3 parameters).

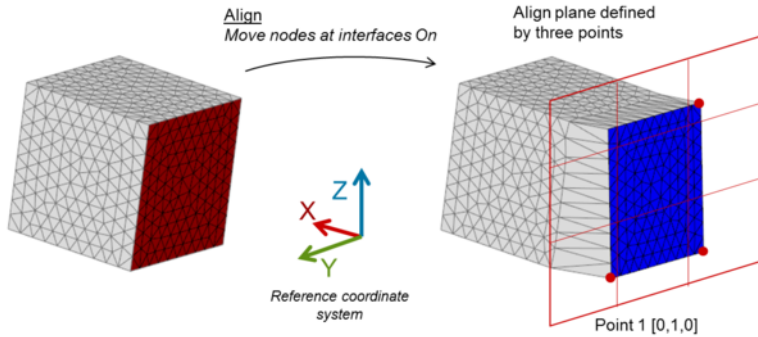

Figure 13.56: Align the face of a cube to a plan using the Align function

Remark. For Replace input PIDs and Move nodes at interfaces parameters please refer to function [Translate](#).

13.9 Other tools

13.9.1 Extract Blade Tool

The Extract blade is a specific ActranVI meshing tool for automatic extraction of profiles from a blade surface mesh. It is only available in a Potential Flow analysis data tree, where a Blade component, as well as its profiles are created during the extraction procedure. It works by setting specific cut planes along the blade mesh to create closed profiles. A visual representation can be seen in [Figure 13.57](#).

The Extract blade tool can be accessed by double clicking on the Extract Blade icon located on the data tree of Potential Flow Analysis. A new property window will pop up, as shown in [Figure 13.58](#), with the following options:

- **Topology:** Selection of topology containing the input blade mesh. Only 2D meshes are supported for this tool
- **Origin:** center of the angular section (extraction surface enclosure) which must be equivalent to the center of the blade to be created.
- **Rotation Axis:** Axis of blade rotation

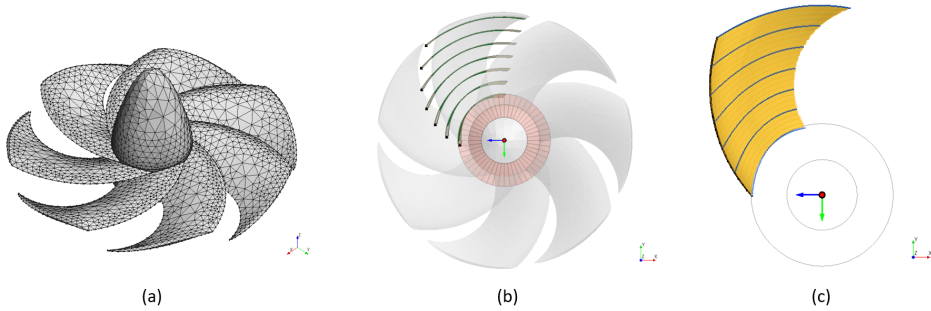

Figure 13.57: Representative scheme explaining the Extract blade tool. (a) Imported blade mesh (or CAD) in ACTRANVI. (b) Setting the blade and cut plane parameters for extracting the profiles. (c) Blade component automatically created with extracted profiles.

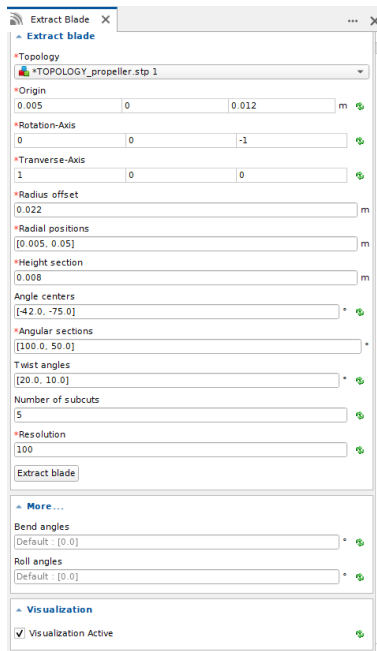

Figure 13.58: Extract blade window.

- **Transverse Axis:** Axis along the blade length
- **Radius Offset:** radial position offset of the cut plane with respect to Origin
- **Radial Positions:** radial positions of the cut planes along the transverse

axis where profiles will be created

- **Height Section:** height of the cut plane at each radial position
- **Angle Centers:** angular position of the cut plane center point on the azimuthal direction of the rotor
- **Angular Section:** angular section of the cut plane with respect to Origin
- **Twist angles:** twist angles (or pitch) at each cut plane. Please check figure ?? for a more detailed explanation about this parameter.
- **Number of subcuts:** number of sub cut planes created between each pair of cut plane
- **Resolution:** number of nodes to define extracted profile resolution on the cut planes
- **More:**
 - **Bend angles:** bend angles (or rake) at each cut plane. Please check figure ?? for a more detailed explanation about this parameter.
 - **Roll angles:** roll angles (or screw) at each cut plane. Please check figure ?? for a more detailed explanation about this parameter.
- **Visualization:** activate real-time visualization of the axis and cut planes

ACTRANVI Unit Systems

14.1 Introduction

Since ACTRAN 2020, unit systems are fully supported within the solver and the graphical user interface. This feature includes:

- The display of the unit of any parameter inside ACTRANVI;
- The capability to convert in one click a complete analysis (or one of its ingredients) from one unit system to another;
- The ability to handle seamlessly modal components, topologies, materials, ... defined in different unit systems.

The following sections aim at detailing the different points mentioned above.

14.2 Unit system levels

Before going further, it is mandatory to understand that three different unit system levels exist in ACTRAN:

1. The ACTRANVI unit system;
2. The analysis unit system;
3. Local unit systems in some ingredients of the analysis (modal components, topologies, materials, ...).

The following unit systems are available at each level:

- SI: Meter - Kilogram - Second (default value);
- MMKG: Millimeter - Kilogram - Second;
- MT: Meter - Ton - Second;
- MMT: Millimeter - Ton - Second;
- INLB: Inch - Pound-force - Second;
- FTLB: Foot - Pound-force - Second.

14.2.1 ACTRANVI unit system

The first level corresponds to the ACTRANVI **unit system**. It is set in the [Settings](#) of the application and is used for two aspects.

On the one hand, it defines the unit system of the visualization, that is to say the length unit of the render window (viewports) and of the "Measure", "Info" and "Mesh quality" tabs (see Figure 14.1). Note that the application needs to be closed and re-opened to function properly after a change in the unit system setting.

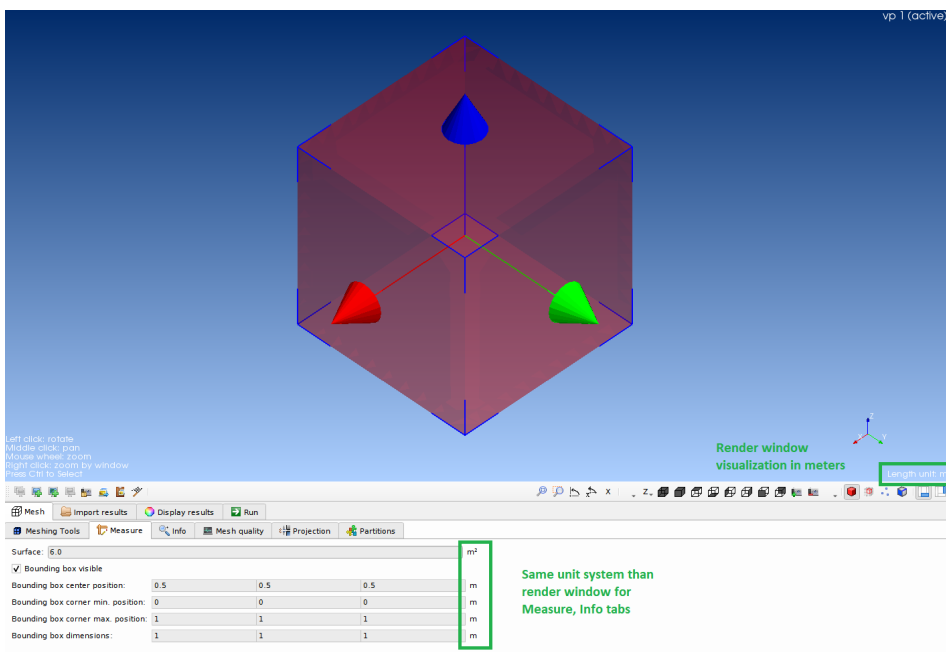

Figure 14.1: The ACTRANVI unit system determines the visualization length unit

On the other hand, the ACTRANVI unit system is used as a default value to initialize the unit system of any new analysis, topology, material or table created within the application. In addition, when importing an analysis created by a version of ACTRAN older than the 2020 release, its unit system will be taken as the one of the application. A warning message (see Figure 14.2) is displayed on screen in this situation.

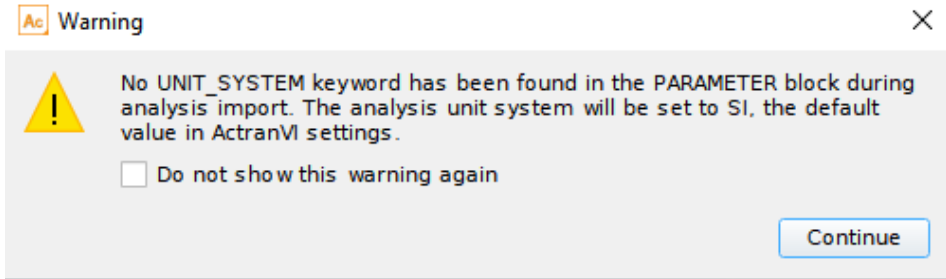

Figure 14.2: The ACTRANVI unit system is used if no unit system information is available in the input file

14.2.2 Analysis unit system

The second level is the **analysis unit system**. Most importantly, this is the unit system in which the computation is run. The unit system of a new analysis created in ACTRANVI is initialized following the application unit system. At any moment, the unit system of an analysis can be changed in the header of its property window (see Figure 14.3).

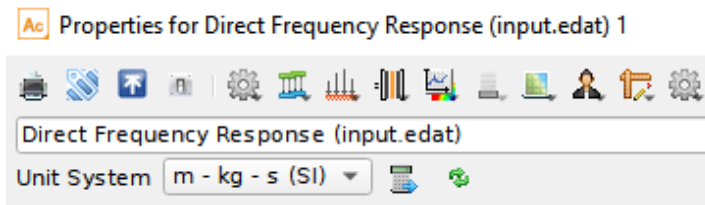

Figure 14.3: The analysis unit system can be found in its property window

Remark. *Although it is not mandatory, it makes sense to use ACTRANVI in the same unit system as the analyses that are usually dealt with. The usage of the unit system feature in the graphical user interface is thereby more natural.*

In the ACTRAN input file, the analysis unit system is defined in the [PARAMETER](#)

datablock. Two cases can be distinguished when importing an analysis:

- A specific unit system is defined in the [PARAMETER](#) datablock: it unambiguously defines the analysis unit system;
- No unit system information is available in the [PARAMETER](#) datablock: the unit system of the imported analysis is set to the ACTRANVI unit system.

From the solver point of view, the analysis unit system is the one in which the computation is performed. Therefore:

- Prior to the computation, the solver will automatically convert the properties of modal components, topologies, materials, ... from their local unit system (see below) to the analysis unit system;
- All the output results (FRF, maps, ...) will be expressed in the analysis unit system.

14.2.3 Local unit systems

For some ingredients of the analysis, the user has now the possibility to define unit systems at a third level, namely as **local unit systems**. These can be different from the analysis unit system. The list of entities supporting a local unit system is given below:

- [TOPOLOGY](#) ;
- [MATERIAL](#) ;
- [TABLE](#) ;
- [FIELD](#) ;
- [BC_MESH](#) ;
- [MODAL_ELASTIC](#) , [MODAL_ACOUSTIC](#) , [VISCOTHERMAL_MODAL_ACOUSTIC](#) and [SUPERELEMENT_DMIGOP2](#) .

In ACTRANVI, the initial local unit system of a newly created entity depends on its nature:

- For new fields, modal components, superelements and BC Mesh boundary conditions: the local unit system is inherited from the analysis unit system;

- For new topologies, materials and tables (which do not refer to an analysis): the local unit system is set to the ACTRANVI unit system.

As for the analysis unit system, a local unit system can be changed at any moment in the header of the property window (see Figure 14.4).

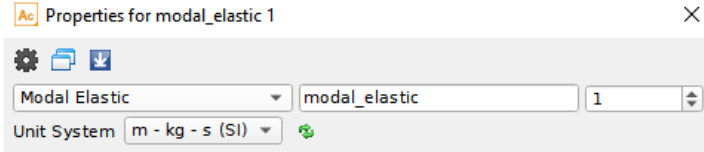

Figure 14.4: The local unit system can be found in the property window of its entity

When interpreting an ACTRAN input file, local unit systems that are not explicitly specified (using the appropriate keyword) are supposed to be the same as the analysis unit system.

14.3 Unit display

The units of any property having a physical dimension are displayed in the property window of any analysis, component, boundary condition, ... These units are expressed in the analysis unit system, or in the local unit system when it exists.

In the example of Figure 14.5, the units are displayed in MMT for the fluid material (local unit system), but the thickness of the thin shell component is displayed in SI (no local unit system, hence unit system of the analysis).

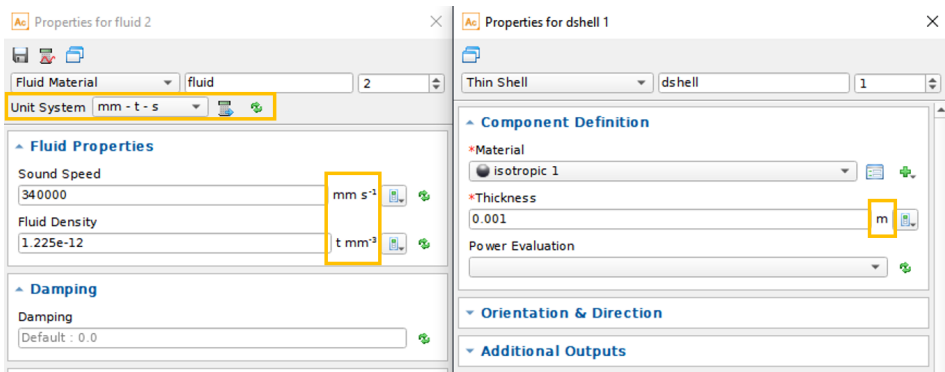

Figure 14.5: Display of units

14.4 Unit conversion

14.4.1 In ACTRANVI

All unit systems presented in the previous sections can be changed by the user in a single click, using tools available in the property windows of analyses and entities supporting local unit systems. When changing a unit system, the user can choose whether physical properties will be converted or not. The following examples illustrate the two possibilities.

Let us take a fluid material for which the speed of sound is set to 340000 and the fluid density to $1.225e^{-12}$ (see Figure 14.6). These values correspond to air properties expressed in MMT. However, the local unit system of the fluid material is initially defined as SI. To reach a consistent state, the user needs to switch the unit system from SI to MMT without conversion of the fluid properties. This is done by simply changing the local unit system in the property window. The fluid material is finally defined in MMT with consistent properties.

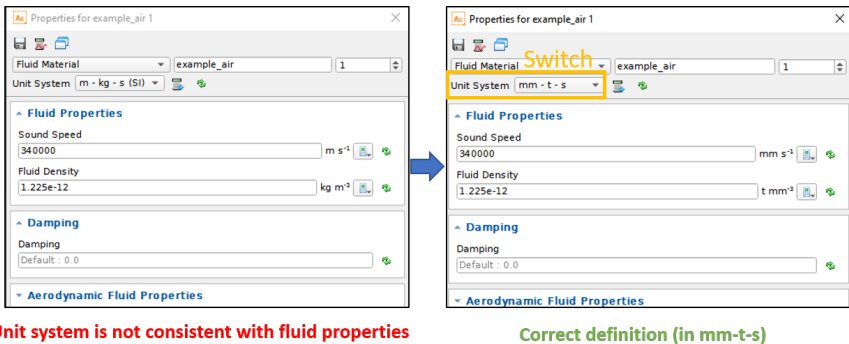

Figure 14.6: Unit system change without conversion of properties

Remarks

- If the unit system change is performed on the analysis, it will only impact the components, boundary conditions, ... which do not have a local unit system.
- The fluid material expressed in MMT can be referred in an analysis defined in SI. The conversion of fluid material properties will be performed automatically within the solver.

Let us now imagine that the fluid material is properly defined in MMT, but that the user wants to have it expressed in another unit system (see Figure 14.7). In this case, one needs to switch the unit system and to convert the properties of

the material. This is done by using the unit conversion tool accessible through a button in the property window. This tool performs the complete operation at once. After the desired target unit system has been specified, the local unit system of the material is adjusted and its properties are automatically converted.

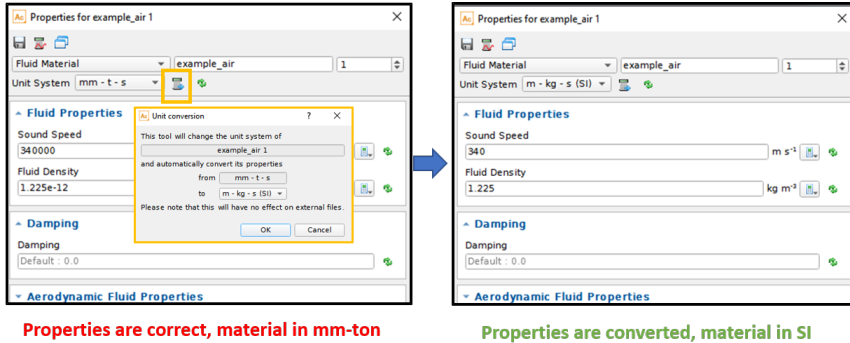

Figure 14.7: Unit system change with conversion of properties

Remarks

- The unit conversion does not have any impact on external files.
- If the unit conversion is performed on the analysis, it will only impact the components, boundary conditions, ... which do not have a local unit system.
- The modal components, superelements and fields do not have the unit conversion tool. Indeed, they do not have properties with a physical dimension that would need to be converted.

A tool is available in ActranVI to change many unit systems at once. The layout of this *Global unit system change* tool is shown in Figure 14.8.

The tool can change the unit systems of either or all of the followings:

- all topologies,
- all materials,
- all tables and/or
- any analyses

with or without automatic conversion of their properties.

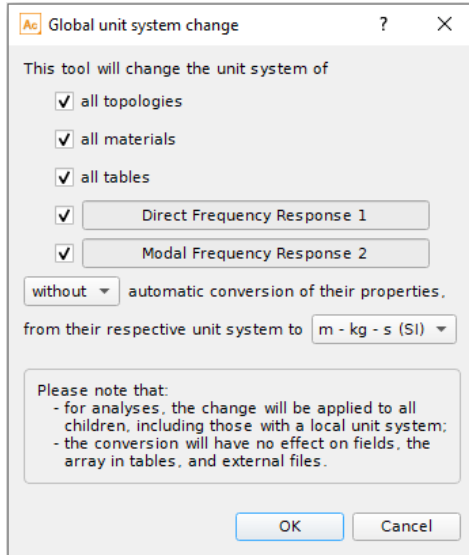

Figure 14.8: Layout of the Global unit system change tool

Remarks

- For analyses, the change is applied to all children, including those with a local unit system.
- The conversion does not have any effects on fields, the array in tables, and external files.

14.4.2 In the solver

When local unit systems different from the analysis unit system are detected in an input file, the solver will convert automatically the related properties from the local unit systems to the analysis unit system, before running the computation. It is therefore now possible to define an analysis in SI containing:

- a topology expressed in MMKG;
- a Finite Fluid component referring to a fluid material expressed in INLB;
- a Modal Elastic expressed in MMT;
- a Porous UP component referring to a poro-elastic material expressed in MT;
- ...

This analysis can be exported in an ACTRAN input file and run as is, without any effort from the user.

14.5 Compatibility with the keywords LENGTH_UNIT and MASS_UNIT

In versions of ACTRAN older than the 2020 release, local unit systems already existed for topologies, modal components and BC Mesh boundary conditions. They were then handled in terms of LENGTH_UNIT and MASS_UNIT keywords. While backward compatibility is ensured, these keywords will be replaced by the UNIT_SYSTEM keyword from ACTRAN 2020 onwards.

When importing an analysis containing LENGTH_UNIT and MASS_UNIT keywords, ACTRANVI will adapt the local unit system of the topologies, modal components or boundary conditions accordingly. For instance let us imagine that we import in ACTRANVI set in SI (in the settings) an analysis without unit system information in the PARAMETER datablock, but containing a modal elastic component with LENGTH_UNIT = 0.001 and MASS_UNIT = 1000. In this situation, the analysis unit system will first be set to SI. Then, the LENGTH_UNIT and MASS_UNIT will be interpreted with respect to this analysis unit system, leading to the local unit system MMT for the modal elastic component.

If the LENGTH_UNIT and MASS_UNIT values cannot be matched to a supported unit system, a clear warning message will be displayed on screen at the import of the analysis (see Figure 14.9). In that situation, the user should first check that the unit system set for the analysis is correct. If not, the appropriate unit system information should be added in the PARAMETER datablock of the input file, to ensure that the analysis unit system is determined with no dependence on the application setting. If the problem persists even with the correct analysis unit system, we advise the user to adapt manually the topology dimensions using for instance the "Scale" meshing tool.

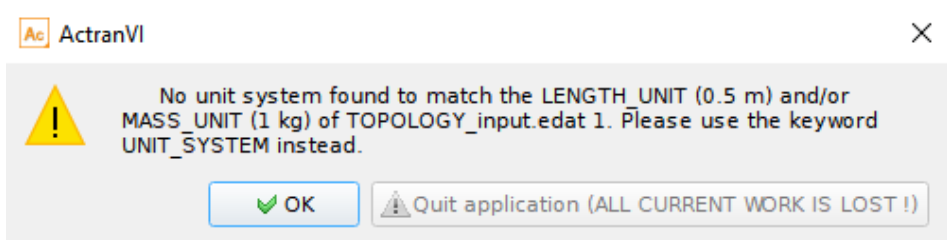

Figure 14.9: Error message displayed when no matching is found between old LENGTH_UNIT and MASS_UNIT keywords and a currently supported unit system

ACTRANVI Material Encryption

15.1 Introduction

Since ACTRAN 2023, it is possible to encrypt materials so that users can exchange material data to run simulations but without giving access to material properties considered as industrial secrets. Two possible workflows can be followed inside ACTRANVI:

- Encrypt a material used inside the analysis;
- Export a material in an encrypted format. This material can be used afterwards in an analysis.

In both cases, material encryption is handled through the Graphical User Interface. Also, encryption settings play an important role in restricting the access to the encrypted material.

Please note that encryption operation is not reversible.

In the following sections, we will detail the different points mentioned above.

15.2 Encryption settings

Before starting any material encryption, the user should pay attention to the settings used for it. In ACTRANVI settings panel, users have the possibility to define the three following parameters (as shown in [15.1](#)):

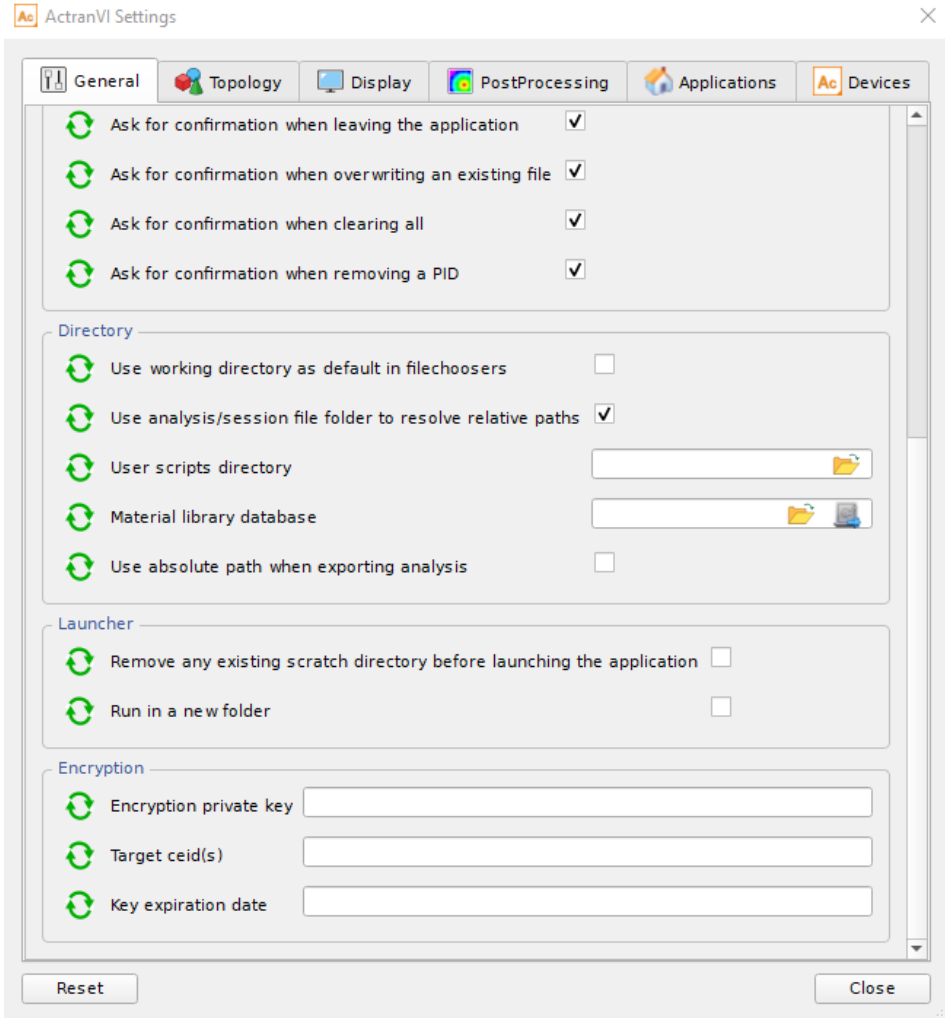

Figure 15.1: Encryption settings

- **Encryption private key:** this is the key that allows the usage of the encrypted material. By default, a random key is generated;
- **Target ceid(s):** this is the Customer Entitlement ID (CEID). The CEID is very important to target only the user(s) that will be able to use the encrypted material. Only a single CEID can be specified. It is also possible to use the keyword (current) that is equal to specify the CEID of the user that is performing the encryption and the keyword `a11` that entitles every user. By default, it is set to `a11`;

- **Key expiration date:** This allows to specify the limitation in time of the encrypted file. The default value is set to none (no expiration in time). If requested, the expiration date should be introduced in the following format dd/mm/yyyy.

15.3 Encrypt a material used inside the analysis

One workflow is to encrypt one or multiple materials that are used in an Actran analysis.

Once the settings are specified, the user can encrypt the material as follows:

- Go in the contextual tab of the material in the ribbon and use the encryption button;

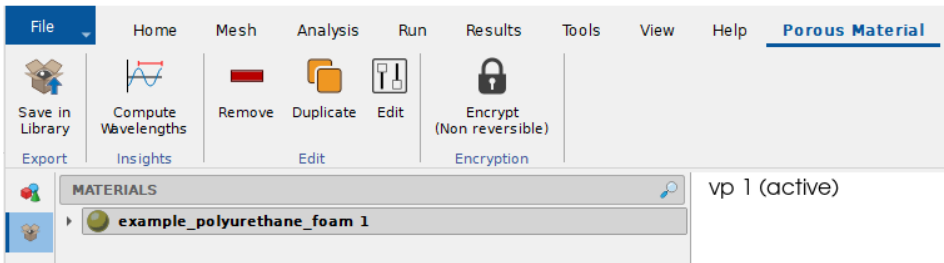

Figure 15.2: Encrypt material in the material contextual tab

- Right click on the material in the datatree and select **Encrypt Material**;

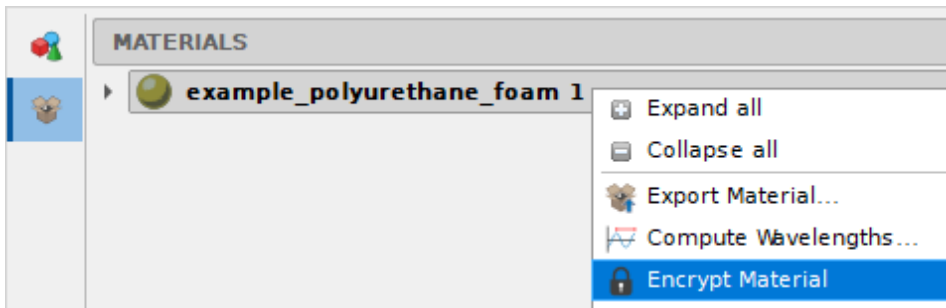

Figure 15.3: Encrypt material in the right click menu datatree

Both ways are equivalent. Once the material is encrypted in the interface, it is not possible to retrieve the original properties. An encrypted material can be

distinguished from the others since its icon in the datatree is superimposed by a lock.

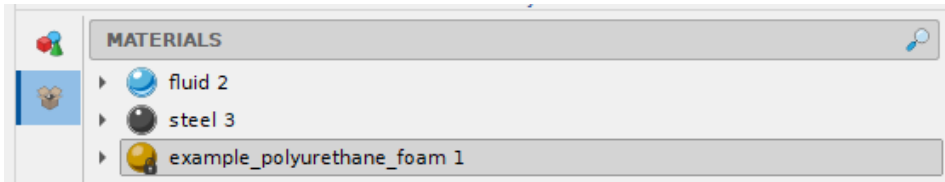

Figure 15.4: Encrypted material in the datatree

15.4 Export a material in an encrypted format

Materials can be encrypted independently from a specific analysis. In this case, the workflow consists in exporting all materials by right-clicking on "Materials" and choose the encrypted format Actran *.edat or *.dat and *.bdf. Note that it is not possible to export (and encrypt) a single material only ; all materials should be exported at once.

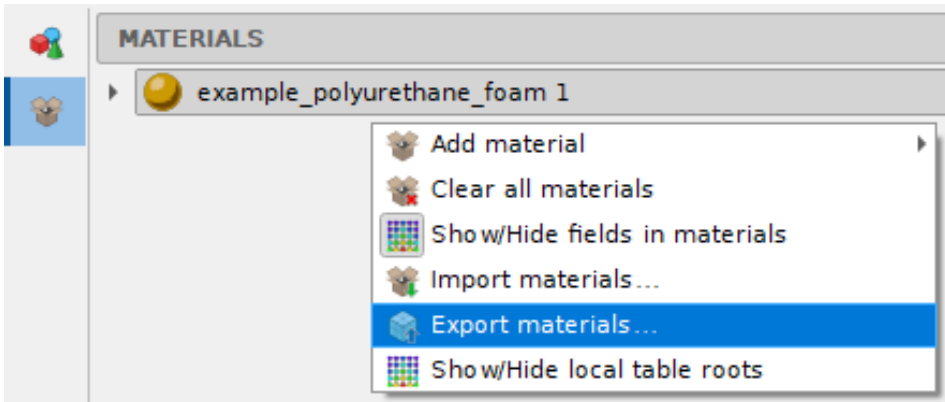

Figure 15.5: Encryption at the export

Material properties will still be visible in ACTRANVI.

15.5 Limitations

Encrypted material is supported only for fluid, solid and porous materials. Materials referring to table properties cannot be exported in *.bdf file format. Users can specify only one target ceid at the time.

Part III

PLTVIEWER Reference Guide

PLTVIEWER Overview

16.1 Introduction

The PLTVIEWER is the dedicated post-processing utility to visualize ACTRAN and experimental frequency response functions (FRF). It contains various operators (such as dB, TL indicator, NR indicator,...) which allows computing, plot, compare and export a wide range of quantities.

The main components of the PLTVIEWER User Interface are listed below and displayed in Figure 16.1:

1. **Menu:** The menu gives access to main functionalities;
2. **Data Tree:** The data tree contains all imported quantities from PLT, UNV, TXT, CSV, ACTRAN WAV, MDF and PUNCH files. Please refer to Chapter 18 for more details
3. **Function Panel:** This panel is used to define the functions that are plotted in the figures. These XY functions usually refer to results available in the Data Tree Content (using certain operators), and respect the Python syntax. Built-in functions are also available. Please refer to Chapter 19 for more details;
4. **Render Window:** The render window (refer to Chapter 20 for more details) manages the visualization of the frequency response functions defined in the Function Panel. It contains 3 panels:
 - (a) *Figure Panel:* Different figures can be created to display the requested quantities.

(b) *Curve Panel*: The curve panel allows editing and controlling the visualization of the different curves present in one figure.

(c) *Figure Properties Panel*: The properties of the figures can be modified in this panel.

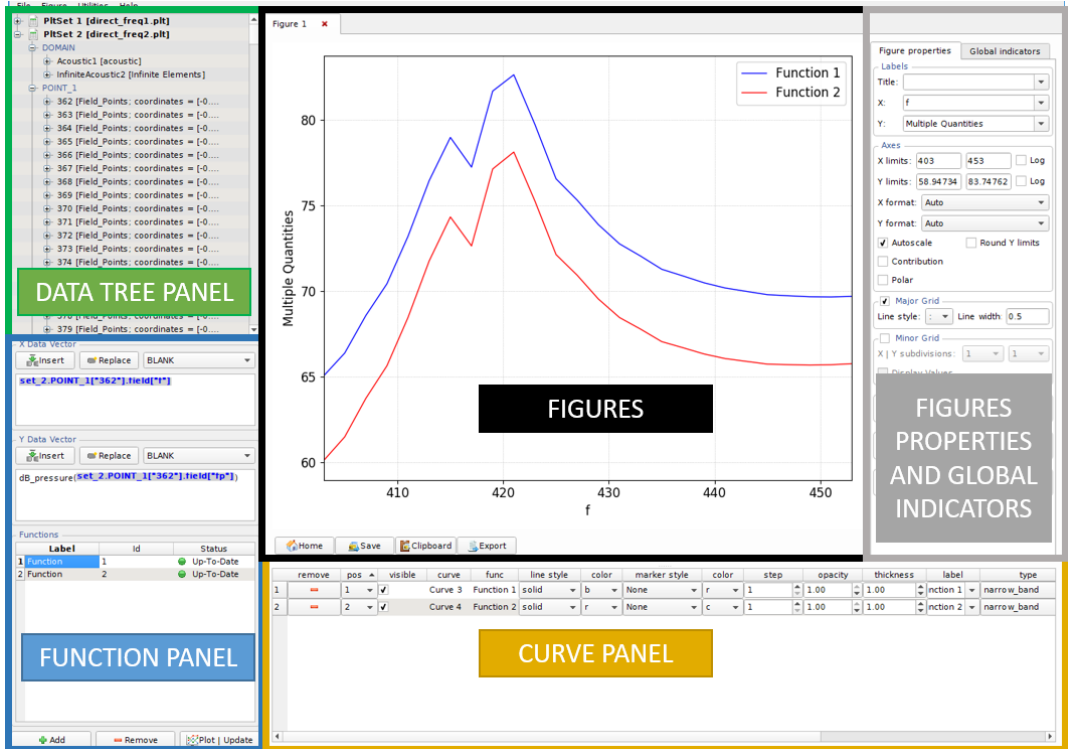

Figure 16.1: Global layout of the PLTVIEWER.

16.2 Launching the PLTVIEWER

Multiple ways for launching the PLTVIEWER are available:

1. The PLTVIEWER can immediately be accessed from ACTRANVI through the toolbar (Tools→PLTVIEWER).
2. PLTVIEWER can be launched from the prompt by typing the command:

```
actran -u PLTVIEWER [-n|--no_graphics] [-x|--execute] ...
                [-i|--import_file] [-b|--background]
```

where

`-n, --no_graphics` : PLTVIEWER will be launched without rendering window (batch mode);

`-b, --background` : PLTVIEWER will be launched in background mode (graphics mode but the application window is minimized in taskbar);

`-x, --execute=` : the execution of the specified PLTVIEWER script will be performed;

`-i, --import_file=` : the specified result file will be imported.

3. For Windows user, the PLTVIEWER can be launched using the shortcut created during installation in Start menu.

On Windows, a result file can also be opened by right-clicking the .plt file.

Trace files and session files are systematically created and contains respectively all software information and the different operation performed within the PLTVIEWER. The session file can be re-used for several purposes, as explained in Chapter [27](#).

PLTVIEWER Menu

The main menu bar is located at the top of the PLTVIEWER application. Different menus are available:

- File;
- Figure;
- Utilities;
- Help.

17.1 "File" menu

The File menu of PLTVIEWER allows performing global actions. These actions are gathered in three groups:

1. Load or export session files (Section [17.1.1](#))
2. Import results (Section [17.1.2](#))
3. Export results (Section [17.1.3](#))
4. Modify the PLTVIEWER settings (Section [17.1.4](#))

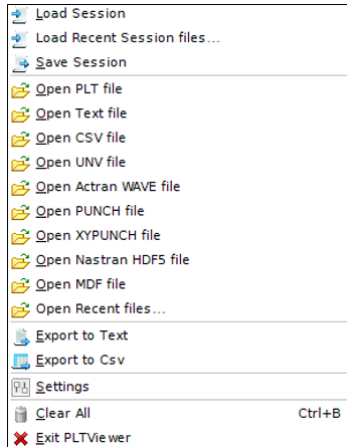

Figure 17.1: Menu of the PLTVIEWER.

17.1.1 Scripting and Session Files

Like for ACTRANVI, an API (Application programming interface) is available for PLTVIEWER in order to write and read PLTVIEWER commands in a session file. When opening the PLTVIEWER, a session file is automatically created. Such file can, for instance, be used for:

- Re-launching PLTVIEWER in the latest state;
- Retrieving a stable status of the PLTVIEWER when a crash appears (by suppressing different lines for instance);
- Re-using a post-processing procedure on a different set of results;
- Automating the post processing operations of ACTRAN PLT files.

The current script file is automatically indented with the commands operated within the PLTVIEWER, written in the python format (www.python.org). Every available command within the PLTVIEWER can be accessed through this API. More information about the Sessions and API of PLTVIEWER can be found in Chapters [30](#) and [27](#).

17.1.2 Importing Results in PLTVIEWER

The PLTVIEWER supports the following results file:

- PLT (ACTRAN result file);

- TXT (ASCII column files);
- CSV (Comma Separated Values files);
- UNV (IDEAS Universal; data block type 58);
- WAVE (Actran wave files);
- PUNCH (Nastran PUNCH files);
- XYPUNCH (Nastran XYPUNCH files);
- HDF5 (Nastran HDF5 files);
- MDF (Adams files).

When importing a PLT file, a plt set is created and its content is displayed in the data tree panel (see Section 18). The leaves of the tree are vectors of data and can be used to create functions.

Text files with columns formatted data (see below) can also be imported.

0	5.02e-6	5.4
1	4.52e-6	3
2	5.21e-6	6

17.1.3 Exporting Results in PLTVIEWER

Functions that are present within a figure may be exported in ASCII column format (TXT) or comma separated values format (CSV). This allows exporting post-processed results. Exporting results may only be done if the different curves present within the figure have a X vector of the same length.

17.1.4 Settings

In the settings of the PLTVIEWER, the General tab (see Figure 17.2) can be accessed to:

- Select a folder containing all the scripts that you may have written for specific post-processing operations. These scripts are loaded with PLTVIEWER and are therefore available in the python console.
- Choose either or not you want a confirmation for several actions (clear all, ...).

- Choose to overwrite or not the session file created the last time you opened PLTVIEWER. If this option is unchecked, a unique session file is created each time you launch the application.

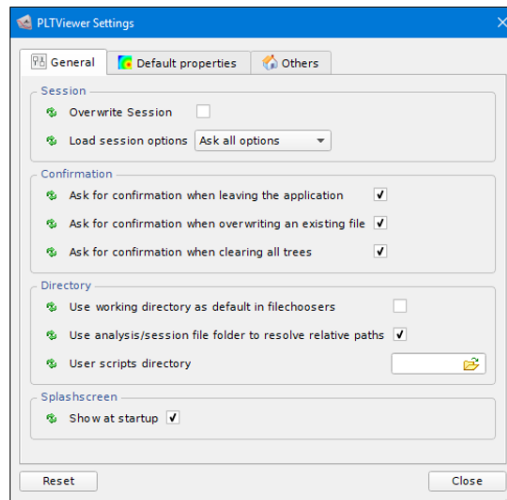

Figure 17.2: PLTViewer Settings: General

In the Default properties tab (Figure 17.3) , various default properties related to the curve plotting can be set.

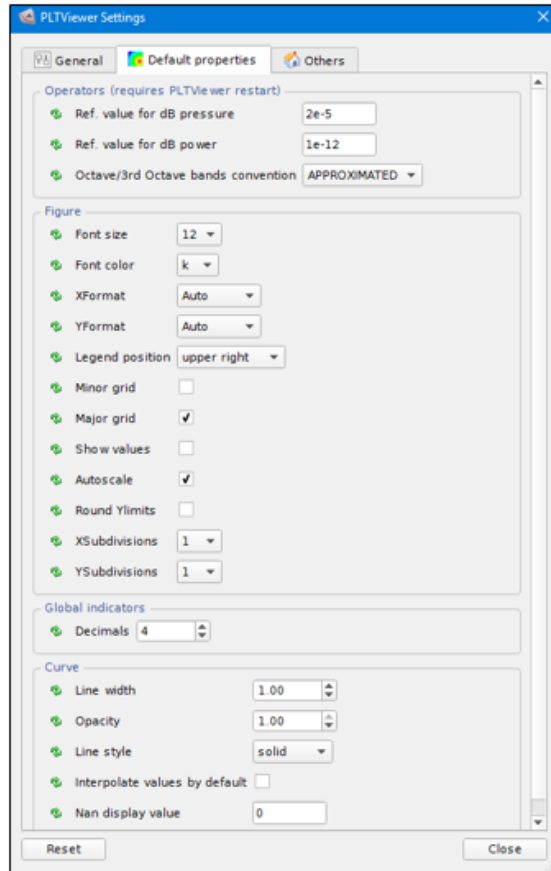

Figure 17.3: PLTVIEWER Settings: Default properties

17.1.5 Remarks and Further Reading

- The `PLT2AUDIO` utility allows generating ACTRAN wave files (please refer to Section 58.13 of Volume 1);
- The format of the ACTRAN `.plt` results file is described in Section 12.5 of Volume 1;
- The `PLT_GET` utility allows post-processing the ACTRAN `.plt` file into column files (see Section 58.1 of Volume 1);
- More information about the API of PLTVIEWER can be found in Chapter 30.

PLTVIEWER Data Trees

18.1 Introduction

The data tree contains all quantities imported from PLT, UNV, TXT, CSV, ACTRAN WAV, MDF and PUNCH files. Each imported file is represented as an individual set that can be renamed or removed. When the data is imported from a file, the results are automatically parsed and subdivided in different sections, depending on the type of imported file.

In general, the PLTVIEWER access arrays of results (with respect to the time or the frequency) for generating functions and plots.

18.2 Content of the Data Tree

The data tree lists all the imported result files, and parses it depending on their type. In general, one can distinguish ACTRAN result file and general ASCII column result files.

For each indicator that is accessible, the number of values is shown in Figure 18.1. One must distinguish vector (1 column) results from matrix (multiple column). The vectors and the matrix data can be distinguished by looking at the icon (see Figure 18.2). Vectors can be used to define X or Y axes of the functions, while matrices or tables are more specifically used for either averaging and/or enveloping operators (Section 19.3) or the WATERFALLVIEWER.

18.2.1 Import of ACTRAN result files

The ACTRAN results file contains different arrays, representing different local (at points) or global quantities (on domains or surfaces) for every loadcases. These are ordered in a tree within the PLTVIEWER that is the exact graphical

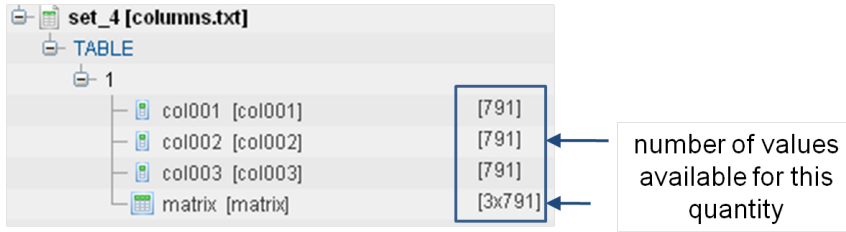

Figure 18.1: Indicator length.

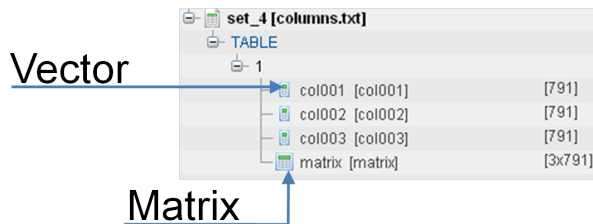

Figure 18.2: Vector and Table quantity.

representation of the content of the PLT file. One can thus distinguish different sections in the tree:

- DOMAIN : storing all global quantities related to the different components such as acoustic, structure domains.
- MODAL_BASIS : storing global quantities related to a modal surface.
- MODE : storing global quantities related to a specific mode of a modal basis.
- POINT : storing local quantities related to a field point.
- NODE : storing local quantities related to a storage node.
- SURFACE : storing global quantities related to a control or coupling surface.
- INTERFACE : storing global quantities related to an interface.
- AUTO_POSTPRO : storing quantities related to an automatic postprocessing.

For sections such a NODE or a POINT, the points coordinates are also available. For a MODE, the modal orders (e.g. radial and azimuthal) and the cut-off frequency are displayed.

Each section may contain multiple leaves (different components or points). These leaves may gather different quantities depending on their nature. Section 12.6 of Volume 1 provides the definition of all the available indicators. For ACTRAN result files, one main indicator that is always present is the frequency (or time) range of the different objects. The entire PLT tree can be expanded and collapsed at once by using the shortcuts 'control+' and 'control-' respectively. The 'control' and '+/-' buttons need to be pressed together after clicking on the PLT tree.

Figure 18.3 show an example of the quantities available in an ACTRAN result file.

Moreover, the unit system in which the set has been evaluated is provided along the set information. This unit system is used when evaluating dB operators.

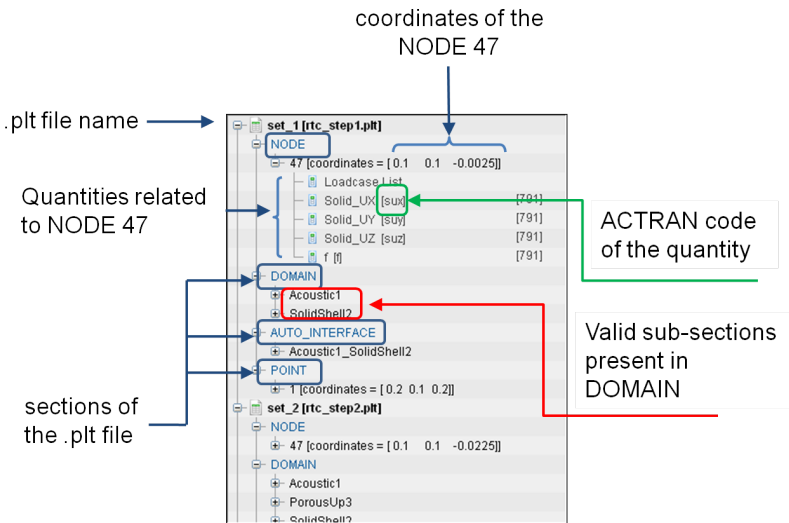

Figure 18.3: Data Tree of an ACTRAN file.

18.2.2 Import of ASCII column files (TXT or CSV)

The supported format for text files being column files, each column is interpreted as being a vector. The number of the different columns corresponds to the appearance of the column in the result file.

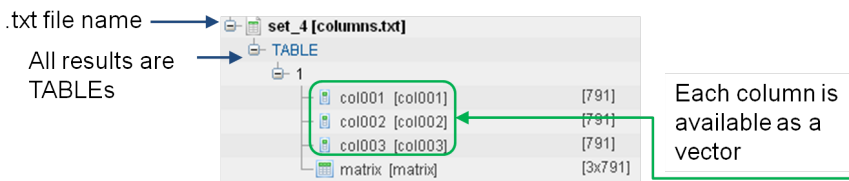

Figure 18.4: Data Tree of an txt file.

18.2.3 Import of modal deformation files (MDF)

ACTRAN supports the import of MDF files (Modal Deformation File) generated by ADAMS multi-body dynamics software. They are usually generated in the frame of an ADAMS analysis including flexible bodies. The MDF file contains one participation factor per mode and per time step. These participation factors are used in combination with an MNF file (Modal Neutral File) to represent the field of vibration of the flexible body. The vibration quantity can be expressed as structural displacement, velocity or acceleration. The MDF file contains participation factors enabling to retrieve each of them:

- Displacement participation factor is stored in LOADCASE 0
- Velocity participation factor is stored in LOADCASE 1
- Acceleration participation factor is stored in LOADCASE 2

If the velocity and acceleration participation factors are not exported in the MDFfile, loadcases 1 and 2 are filled with null values.

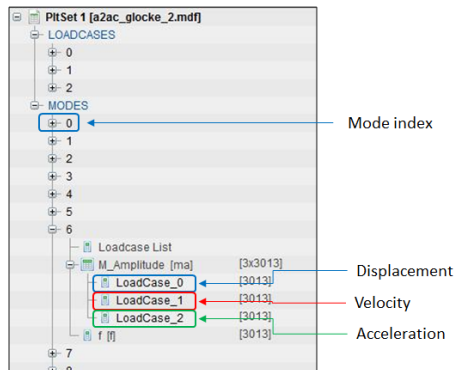

Figure 18.5: Data Tree of an MDF file.

18.3 Reverse Set

The results contained in ACTRAN results file are sorted by frequency or time. This means that usually, one frequency or time array is present in every object present within the PLT file. When dealing with an important amount of objects of the same type (typically, a list of nodes or field points), it may be interesting (typically when one is interested in a directivity plot) to obtain the results sorted by identification number of the object, and not by frequency.

By right-clicking on a result file (See Figure 18.6), a reverse set can be created.

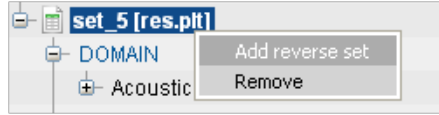

Figure 18.6: Data Tree of an txt file.

As indicated in Figure 18.7, the different results present in the new set are ordered by frequencies, while each vector depends on the identification number of the object.

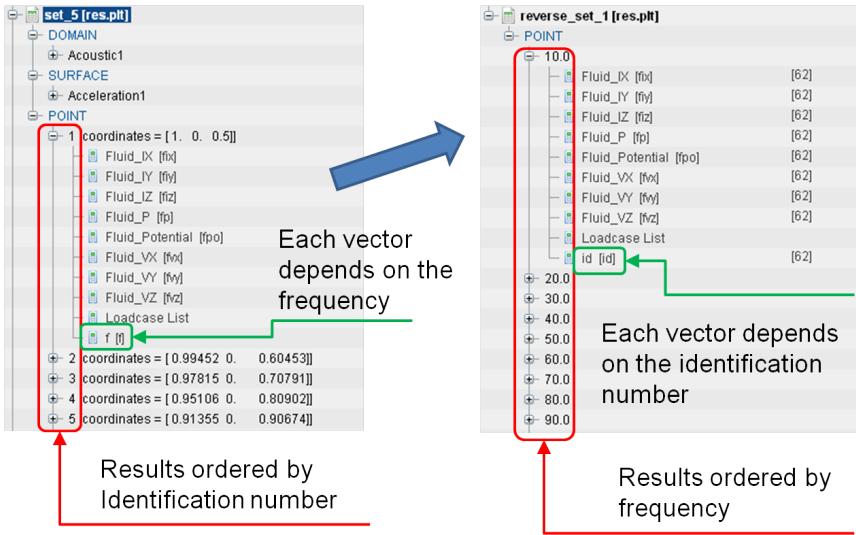

Figure 18.7: Data Tree of a txt file.

18.4 PLT Merge

When multiple ACTRAN simulations are performed separately to cover a large frequency range, the `PLT_MERGE` utility allows merging multiple PLT files. Please refer to Section 58.6 of Volume 1 for further information. This merging operation can also be performed directly in PLTVIEWER.

Select at least two imported PLT sets by pressing the `SHIFT` key. By right-clicking on one of the selected sets (See Figure 18.8), the "merge sets" command is initialized. This function provides the following arguments:

- `Merged set title` : specifies the title of the merged PLT file;
- `Tolerance` : adjusts the frequency or time tolerance. If the difference between two frequencies available on two different files is lower than

this tolerance, the results from the last file overwrite previously available information except if the "force average" checkbox is selected (see below).

- **Axisymmetric order** : allows to merge PLT files with different axisymmetric orders;
- **Load case offset for duct modes** : allows to specify the offset to be applied on the loadcases corresponding to the different duct mode excitations when merging PLTfiles from different axisymmetric orders;
- **Force average** : allows to trigger the averaging of duplicated quantities when the same frequencies/loadcases are present in different PLT files. Mean quantities (averaged over a surface or a volume) are unaffected by this option and are always averaged;
- **Ids Only** : allows to merge results for DOMAIN, SURFACE and INTERFACE data blocks that have the same identifier;
- **Discard nonconverged modes** : allows to discard non converged modes.

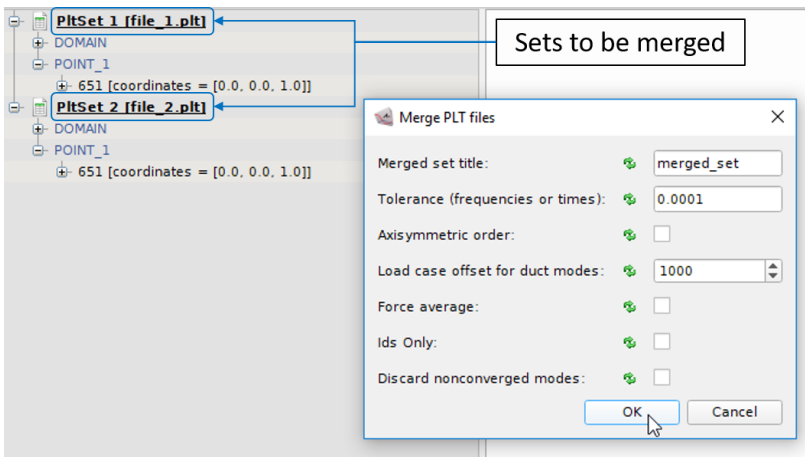

Figure 18.8: Data Tree of sets to be merged.

18.5 Generate Audio File

PLTVIEWER is able to convert an acoustic pressure frequency (or time) response in an audio file in the *.wav format. For frequency cases, the resampling resolution (df) is automatically defined based on the finest resolution between Length and input file df (with a minimum tolerance of $df = 0.001\text{Hz}$). After resampling, an Inverse Fourier Transform (IFT) is applied in the spectrum to create the audio file.

Select a fluid pressure quantity from one available data set. By right-clicking on it (See Figure 18.9), the Convert to audio command can be selected. The dialog window changes according to the data set. In case of *.plt files, the dialog window can be seen in Figure 18.9). When using input data from *.txt files, another options are available with respect to the type of data, as shown in Figure 18.10).

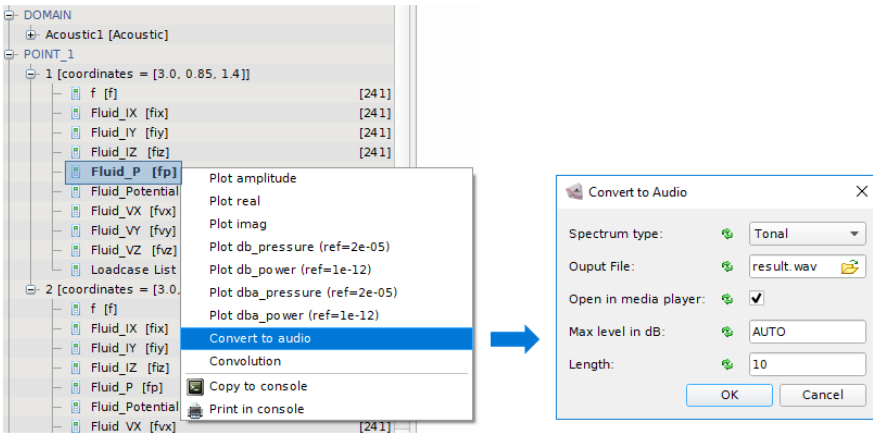

Figure 18.9: One-click audio conversion of pressure data from *.plt input.

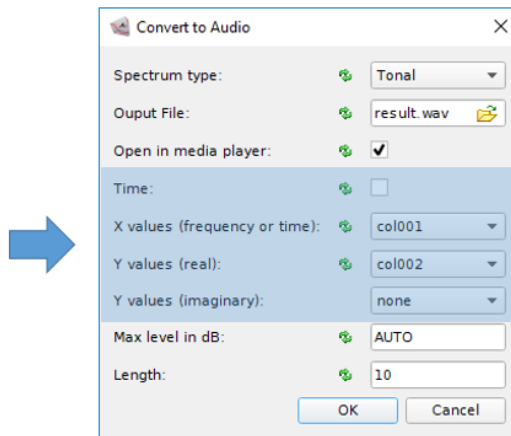

Figure 18.10: One-click audio conversion of pressure data from .txt input.

The following options are available:

- **Spectrum type:** Choose the type of sound spectrum to be created from the selected data set during the resampling procedure:

- Tonal: This option does not apply any interpolation. At the resampling procedure, the pressure values (amplitude and phase) are set to approximations of the frequencies provided in the input file, based on the resampling resolution. For the remaining frequencies (within the audio range), zero amplitude and phase values are set (See Figure 18.11). In order to avoid audio clicks in the output, a fade-in/fade-out with within a time interval of 10% the output audio Length is applied.
- Broadband: This option applies an interpolation between input data points during the resampling procedure. The linearly interpolated values are pressure amplitude and phase (See Figure 18.11). Through the `convert_to_audio` API, there is the option to apply a random phase in the broadband spectrum type, same as the `--random_phase` option shown in Section 58.13 of Volume 1. In order to keep the impact sound feature generated by Broadband type, the fade-in/fade-out (same as the Tonal type) is only applied when using random phase.

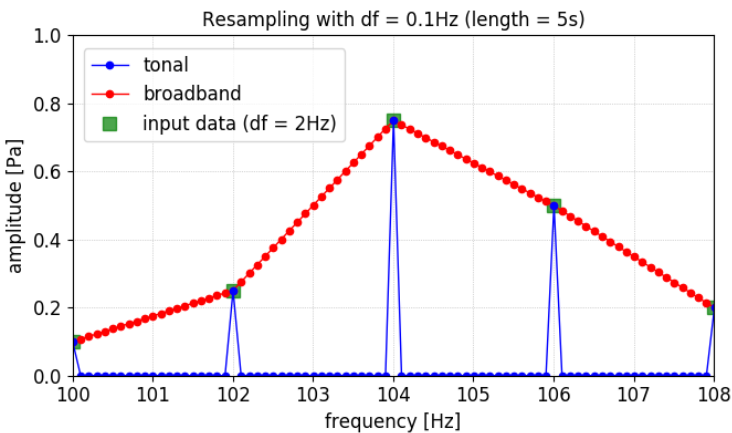

Figure 18.11: Example of spectrum types after resampling of an input frequency data with 2Hz resolution. Interpolation is applied on Broadband spectrum type.

- `Output name`: output audio file name;
- `Open in media player`: the .wav file can be automatically loaded and played using an audio player installed on the working machine;
- `Max level in dB`: .wav file has a dynamic range limited by its 16bits encoding resolution. Signal above this max level are clipped. A signal below the max level minus the dynamic range is ignored. The reference pressure is the one set in PLTVIEWER The default condition is an automatic procedure

which normalizes the output audio with a value of -1dB from the maximum peak.

- **Length:** output .wav file duration in seconds. The resolution will be defined based on a comparison between the input resolution and the Length value which is set (highest resolution is taken considering a tolerance of $df = 0.001\text{Hz}$)

The audio generation can also be executed by ACTRAN through the command line using the PLT2AUDIO utility. Please refer to the PLT2AUDIO function Section 58.13 of Volume 1 for further information.

18.6 Convolution

PLTVIEWER is able to convolve an acoustic pressure frequency response with an existing audio file (*.wav). Pressure results inside an available data set (**fp** in *.plt or columns in *.txt), can be used as transfer function to be considered in a convolution. By right-clicking on the data set (See Figure 18.12), the Convolution function can be selected. The following options are available:

- **Input file:** select an input *.wav file as source audio.
- **Output file:** set the name of the output *.wav file for the convolved audio.
- **Reference pressure:** reference pressure value for the transfer function.
- **Left extrapolation value:** Describes the extrapolation of the transfer function before its smallest defined frequency. The following extrapolation options are available:
 - **pass:** edge extrapolation to reference pressure value
 - **equal:** edge extrapolation to pressure value of smallest frequency
 - **cut:** extrapolates the edge to zero.
- **Right extrapolation value:** Describes the transfer function extrapolation after the value of its highest defined frequency. The extrapolation options are the same as the one shown above for Left extrapolation value, however it is applied at the edge above the input frequency range.
- **Max level in dB:** .wav file has a dynamic range limited by its 16bits encoding resolution. Signal above this max level are clipped. Signal below the max level minus the dynamic range is ignored.

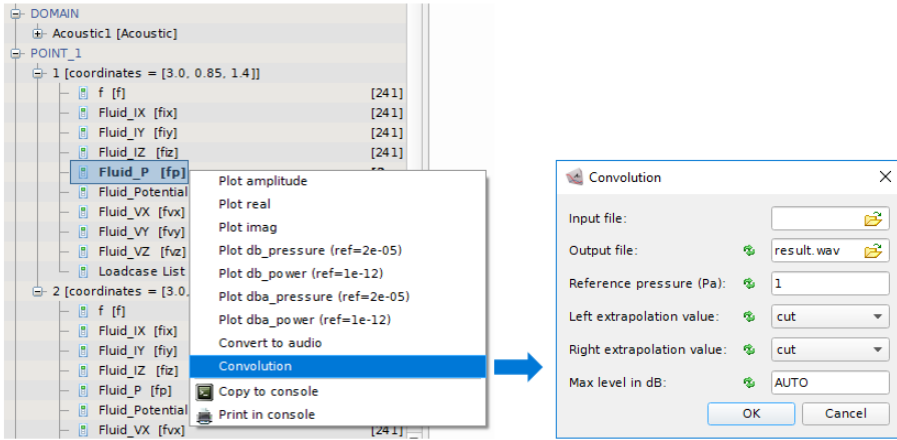

Figure 18.12: One-click Convolution application..

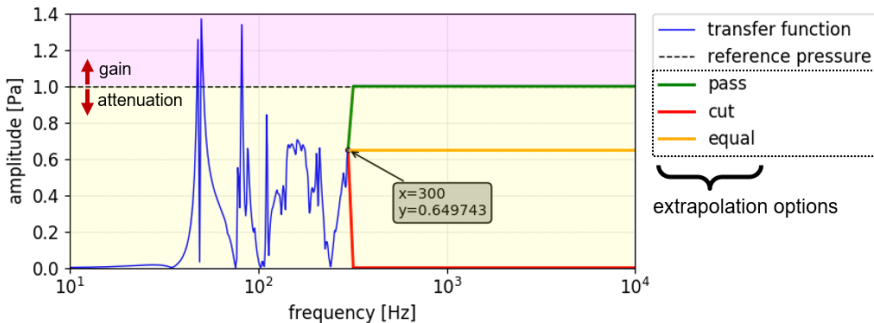

Figure 18.13: Example of a transfer function using different right extrapolation options. The reference pressure is considered as being 1Pa..

The convolution can also be executed by ACTRAN through the command line using the PLT2AUDIO utility. Please refer to the `--convolution` option of PLT2AUDIO function Section 58.13 of Volume 1 for further information.

18.7 Plot Power Balance

PLTVIEWER is able to directly compute the balance of dissipated power within the model's components.

In order to compute and plot the power balance from the imported set, right-click on the set node and click on "Plot Power Balance" (See Figure 18.14).

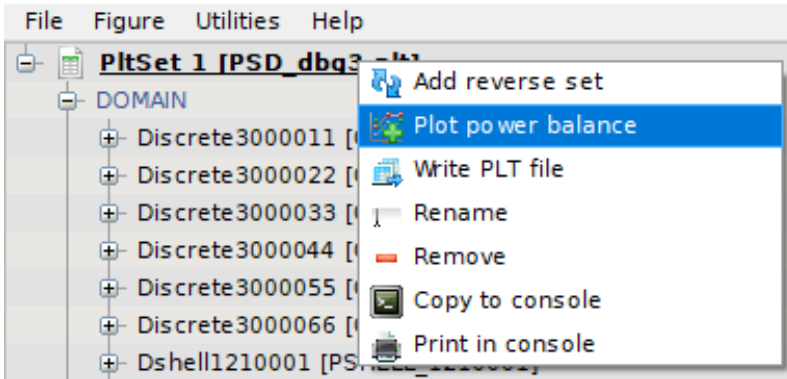

Figure 18.14: One-click plot power balance.

18.8 Write PLT set

PLTVIEWER is able to export an imported set from the following input formats (PLT, UNV, XYPCH, HDF, MDF and PUNCH files) into PLT format. This capability can also be used on merged sets or reversed sets.

In order to export the imported set into PLT format, right-click on the set node and click on "Write PLT file" (See Figure 18.15).

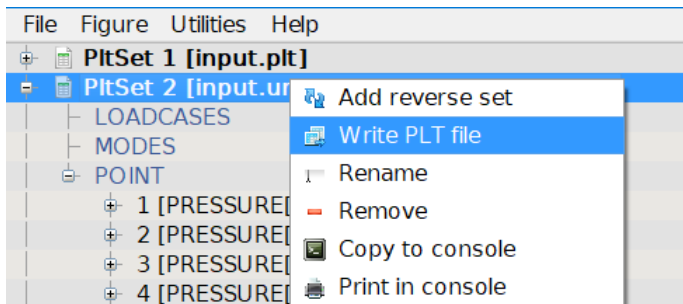

Figure 18.15: Export set into PLT format.

18.9 Apply functions to the imported data

A large set of mathematical functions can be applied to the different available quantities (vectors). This is achieved by drag and dropping the quantity within a quantity container and is extensively described in Chapter 19.

In addition, shortcuts to built-in functions and plots can be accessed by right-clicking on the selected quantity and selecting the desired operator (See figure 18.16). The quantity will be used as the Y data vector, while either the frequency, time or Id will be used for the X data vector.

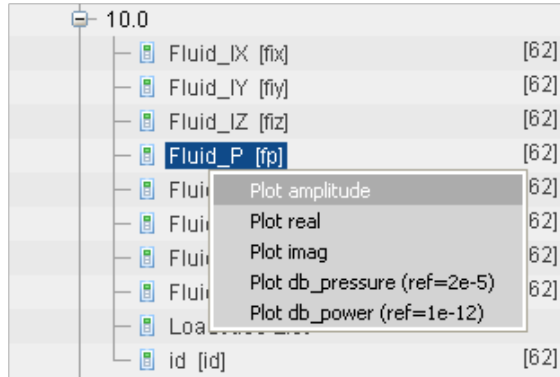

Figure 18.16: One-click function creation.

18.10 Change unit system of a PLT set

It is possible to change the associated unit system of a PLT set. Note that it does not involve unit conversion, only the reference values are set correctly according to the assigned unit system. Figure 18.17 shows how to change the unit system of PLT a set.

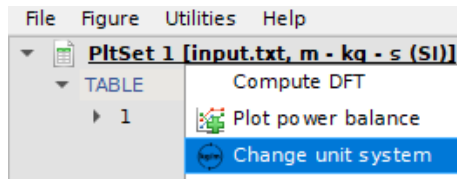

Figure 18.17: Change unit system of a PLT set.

PLTVIEWER Function Panel

19.1 Introduction

In order to plot curves from the imported data on the figures, functions must first be created. A function relates an X data vector with a Y data vector of same length. The X vector usually corresponds to the frequency (or time) and the Y vector is constructed from mathematical expressions applied to one result (or several) computed by ACTRAN.

19.2 Function Definition

A function in the PLTVIEWER is an XY function relating two different data vectors of the same length. This means that one function should always have two arrays provided of same length (see Figure 19.1).

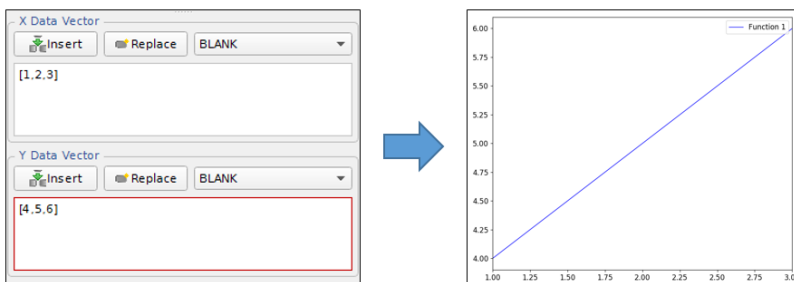

Figure 19.1: Mandatory equal length of the data vectors.

When using data from a result file, the different needed vectors (representing a quantity) can be placed within the X or Y data vector edition box. In order

to support the quantity in the edition, a quantity container (grey data box) can be added at any time within each data vector (see Figure 19.2). When drag and dropping a specific quantity in this quantity container, the name of the selected quantity appears and is contained in the vector (see Figure 19.3).

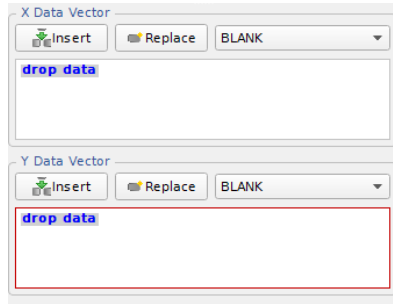

Figure 19.2: Data box supporting an result quantity.

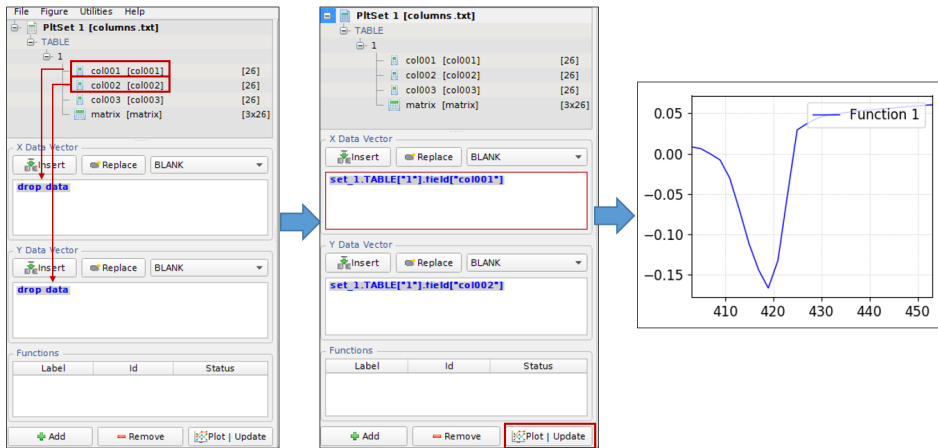

Figure 19.3: Assigning a quantity.

The language used for the data vector edition is the Python language (www.python.org). The mathematical python package used is Numpy (www.numpy.org). This means that various mathematical operations are available within the data vector edition box.

For instance : $20 \log\left(\frac{\sqrt{Quantity^2+Quantity^2}}{2*10e^{-5}}\right)$

becomes (see Figure 19.4): $p\ 20*\log_{10}(\text{sqrt}(\text{array}1**2+\text{array}2**2)/2e-5)$

In addition, predefined operators on arrays are also available. For more information, please refer to Section 19.3.

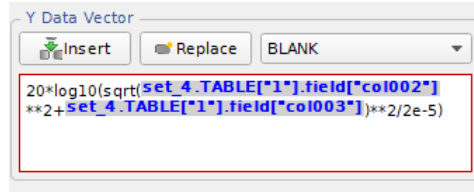

Figure 19.4: Editing a data vector.

Different functions can be created within the PLTVIEWER, and may be plotted or not in different figures. The list of defined functions is placed below the data vector definition boxes, as shown in figure 19.5. When selecting a function, the X and Y data vectors are updated to the selected function. Clicking on the "new" button allows duplicating the currently selected function, but does not create a curve.

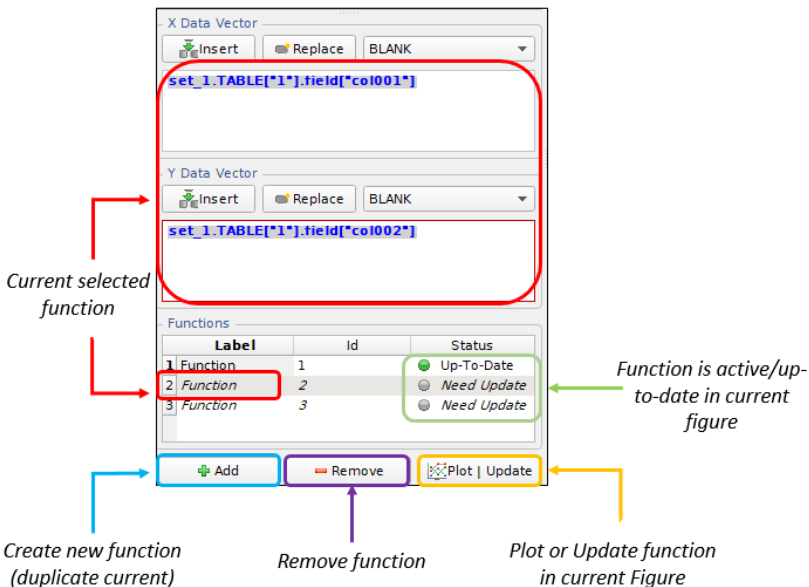

Figure 19.5: Using different functions.

The up-to-date status indicator for each frequency allows controlling whether the function is plotted in a figure, or has been modified since the last plot command. When modifying a data vector of a specific function, the status is disabled, while it may be refreshed by clicking on the "plot/update" button (see figure 19.6). Note that there is no direct relation between the up-to-date status of a function and the visibility of a related curve.

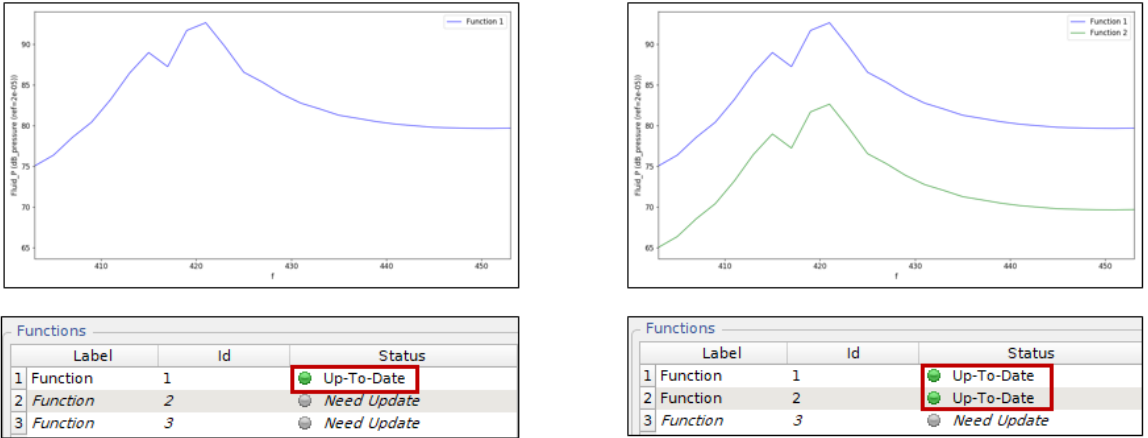

Figure 19.6: Up-to-date status of different functions.

19.3 Built-in functions

A set of built-in operators is available and can be used in the PLTVIEWER (see Figure 19.7).

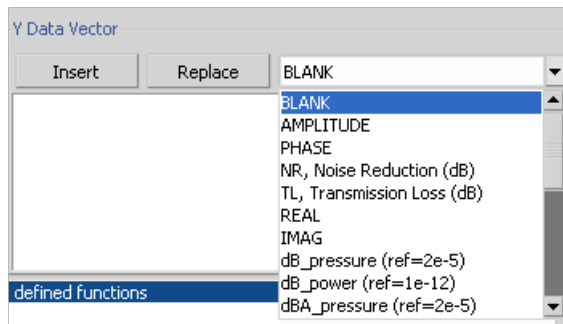

Figure 19.7: Predefined operators for the PLTViewer.

The list of the different operators that are available and their definition is provided in Table 19.1. For dB operators, the reference pressure or power is specified inside the settings, and are set by default to $2e - 5Pa$ and $1e - 12W$. These values are adapted with respect to the unit system of the set, if this latest is available.

Operator	Arguments	Description
AMPLITUDE	array	$\text{sqrt}(\text{array.real} * *2 + \text{array.imag} * *2)$
PHASE	array	$\text{arctan2}(\text{a.imag}, \text{a.real})$
NR	incident, transmitted	$10 * \log_{10}(\text{incident.real} / \text{transmitted.real})$
TL	incident, transmitted	$10 * \log_{10}(\text{incident.real} / \text{transmitted.real})$
REAL	array	<i>array.real</i>
IMAG	array	<i>array.imag</i>
dB_Pressure	array	$20 * \log_{10}(\text{sqrt}(\text{array.real} * *2 + \text{array.imag} * *2) / \text{p_ref})$
dB_Power	array	$10 * \log_{10}(\text{array.real} / \text{power_ref})$
dBA_Pressure	array	$20 * \log_{10}(\text{sqrt}(\text{array.real} * *2 + \text{array.imag} * *2) / \text{p_ref}) + A\text{filter}$
dBA_Power	array	$10 * \log_{10}(\text{array.real} / \text{power_ref}) + A\text{filter}$
dBB_Pressure	array	$20 * \log_{10}(\text{sqrt}(\text{array.real} * *2 + \text{array.imag} * *2) / \text{p_ref}) + B\text{filter}$
dBB_Power	array	$10 * \log_{10}(\text{array.real} / \text{power_ref}) + B\text{filter}$
dBC_Pressure	array	$20 * \log_{10}(\text{sqrt}(\text{array.real} * *2 + \text{array.imag} * *2) / \text{p_ref}) + C\text{filter}$
dBC_Power	array	$10 * \log_{10}(\text{array.real} / \text{power_ref}) + C\text{filter}$
dBD_Pressure	array	$20 * \log_{10}(\text{sqrt}(\text{array.real} * *2 + \text{array.imag} * *2) / \text{p_ref}) + D\text{filter}$
dBD_Power	array	$10 * \log_{10}(\text{array.real} / \text{power_ref}) + D\text{filter}$
Afilter	freq	$20 * \log_{10}(A / A1000)$
Bfilter	freq	$20 * \log_{10}(B / B1000)$
Cfilter	freq	$20 * \log_{10}(C / C1000)$
Dfilter	freq	$20 * \log_{10}(D / D1000)$
MEAN	operator(array(lc))	$\text{sum}(\text{operator}(\text{array}(\text{lc}))) / \text{lc}$
PSD	operator(array(lc))	linear object: $\text{sum}((\text{array}(\text{lc})) * *2) / \text{lc}$, quadraticobject : $\text{sum}(\text{operator}(\text{array}(\text{lc}))) / \text{lc}$
ENV	operator(array(lc))	$[\text{min}(\text{operator}(\text{array}(\text{lc}))), \text{max}(\text{operator}(\text{array}(\text{lc})))]$
MENV	operator(array(lc))	Computes an envelope of all possible mean values computed using lc-1
STD	operator(array(lc))	$[\text{MEAN}(\text{array}) - (\text{sqrt}(\text{MEAN}(\text{array} * *2) - \text{MEAN}(\text{array}) / 2)), \text{MEAN}(\text{array}) + (\text{sqrt}(\text{MEAN}(\text{array} * *2) - \text{MEAN}(\text{array}) / 2))]$
CONFIDENCE	operator(array(lc))	Compute confidence intervals insuring 5% of the results are below the interval, while 5% of the results are above the interval.
VECTOR_NORM	a1, (a2), (a3)	$\text{sqrt}(a1.\text{real} * *2 + a1.\text{imag} * *2 + a2.\text{real} * *2 + a2.\text{imag} * *2 + a3.\text{real} * *2 + a3.\text{imag} * *2)$
ISO-3744 power level	field_points	Compute the power level based on field point pressure results following the ISO norm 3744, see below
FORCE_TYPE	array,type,[ref]	Modify/specify the array type: 'l' = linear, 'q' = quadratic, 'dB' = dB for Pressure, 'f' = frequency)
HIGHLIGHT_FREQUENCIES	line	Creates vertical lines highlighting the particular frequencies provided in x

where:

- $A = ((12200 * *2) * (freq * *4)) / ((freq * *2 + 20.6 * *2) * (freq * *2 + 12200 * *2) * (freq * *2 + 107.7 * *2) * *0.5 * (freq * *2 + 737.9 * *2) * *0.5)$
- $A1000 = ((12200 * *2) * (1000 * *4)) / ((1000 * *2 + 20.6 * *2) * (1000 * *2 + 12200 * *2) * (1000 * *2 + 107.7 * *2) * *0.5 * (1000 * *2 + 737.9 * *2) * *0.5)$
- $B = ((12200 * *2) * (freq * *3)) / ((freq * *2 + 20.6 * *2) * (freq * *2 + 12200 * *2) * (freq * *2 + 158.5 * *2) * *0.5)$
- $B1000 = ((12200 * *2) * (1000 * *3)) / ((1000 * *2 + 20.6 * *2) * (1000 * *2 + 12200 * *2) * (1000 * *2 + 158.5 * *2) * *0.5)$
- $C = ((12200 * *2) * (freq * *2)) / ((freq * *2 + 20.6 * *2) * (freq * *2 + 12200 * *2))$
- $C1000 = ((12200 * *2) * (1000 * *2)) / ((1000 * *2 + 20.6 * *2) * (1000 * *2 + 12200 * *2))$
- $D = (freq * (((1037918.48 - freq * *2) * *2 + (1080768.16 * freq * *2)) / ((9837328 - freq * *2) * *2 + (11723776 * freq * *2)))) * *0.5) / (6.8966888496476e - 5 * ((freq * *2 + 79919.29) * (freq * *2 + 1345600)) * *0.5)$
- $D1000 = (1000 * (((1037918.48 - 1000 * *2) * *2 + (1080768.16 * 1000 * *2)) / ((9837328 - 1000 * *2) * *2 + (11723776 * 1000 * *2)))) * *0.5) / (6.8966888496476e - 5 * ((1000 * *2 + 79919.29) * (1000 * *2 + 1345600)) * *0.5)$
- $ISO3744 = 20 * \log(\sqrt{\sum(fluid_pressure * *2) / num_points} / \sqrt{2} / ref_db_pressure) + 10 * \log(surface_area * length_unit)$

19.4 Octave operators

PLTVIEWER is able to compute and display data in narrow band (default), but also in octave/mean octave, 1/3th octave/mean octave, 1/6th octave/mean octave, 1/12th octave/mean octave and 1/24th octave/mean octave bands. These bands can be either the exact octave bands or one-third octave bands including non-fractional numbers, or the conventional rounded numbers due to the ISO standard. This can be set in the PLTVIEWER Settings window, tab Default properties, Octave and 3rd octave band convention.

This section explicits the octave formulations used in PLTVIEWER. Since they depend on the nature of the data, the following section introduces first the different function data type available in PLTVIEWER.

19.4.1 Function data types and dB reference

Any plotted function in PLTVIEWER has a type, characterizing the nature of its underlying data. Depending on this function data type, the corresponding octave/mean octave data will be computed in a different way. The different data type available in PLTVIEWER are :

- *f* : undefined data type, no type can be associated to the function data. This is for instance the case when the user is creating a function from text file imported data, or when the X Data and Y Data vectors are lists directly provided by the user. In these scenarios, an undefined type is associated to the data since PLTVIEWER is not able to know the exact nature of the data ,
- *l* : linear data type. Fluid pressure (*fp*) (in [*Pa*] units), fluid potential (*fpo*), fluid velocity (*fv*), solid displacements (*su*) and rotations (*sr*), forces and moments, are associated to linear data type ,
- *q* : quadratic data type. Any quadratic indicator, typically intensities or power indicators, as fluid intensity (*fi*), radiated power (*rP*) or incident powers (*iP*), PSD indicators, square indicators, are associated to quadratic data type ,
- *dB* : function data is expressed in decibels [*dB*] scale (logarithmic scale). Any dB operators, such as dB_pressure, dB_power, ... applied on Y Data vector will lead to a function with underlying *dB* data type ,
- *TL* : function data corresponds to a Transmission Loss (or Noise Reduction) indicator. TL and NR operators applied on Y Data vector will lead to a function with underlying *TL* data type.

In addition to the function data type, there is also a dB reference associated to function data. This parameter is only useful when the data type is *dB*. In such a case, PLTVIEWER has to determine if the data is *linear dB* data (dB_pressure) or *quadratic dB* data (dB_power), because the dB reference is not the same for these two different types of data. Let's consider the general expression for converting pressure quantity to *dB* units :

$$p_{dB} = 20 \log \left(\frac{p}{p_{ref}} \right) \quad (19.1)$$

In the above expression, p_{ref} is a given reference level. dB reference level for pressure is 2.10^{-5} (this is the default *dB* reference of any function created in PLTVIEWER. Those values can be changed in PLTVIEWERSettings window), while *dB* reference level for power is 1.10^{-12} .

Important remark : in PLTVIEWER, the pressure is used instead of the effective pressure in the dB expression ($p_{eff} = p/\sqrt{2}$)

The function data type can be set at the creation of the function by the user. The *FORCE_TYPE* operator applied to Y Data Vector allows for setting *plt_type* parameter (function data type) and *db_ref* (function dB reference). For instance, for creating a function using simple PYTHON lists, the following Y Data Vector

$$FORCE_TYPE([1,2,3,4,5], plt_type = "dB", db_ref = "1e - 12") \quad (19.2)$$

will tag the created function's data as dB (*plt_type* = "dB") quadratic (*db_ref* = "1e - 12") data.

NB : the *db_ref* parameter should be provided as a string, in the format $[0 - 9]e[+-][0 - 9]$.

Remark : when handling reverse data, X Data vector does not correspond to frequencies but to Ids (of microphones for instance). If we want to display results using a particular operator which depends on the frequency (as a dBA operator for instance), it is necessary to specify explicitly the xarray argument to the operator. For instance, if the corresponding frequency is 600Hz, we would consider:

$$dBA_pressure(set_1.POINT_1["600.0"].field["fp"].lc[1], xarray = [600]) \quad (19.3)$$

19.4.2 Octave formulations in PLTVIEWER

A sound level in a particular frequency band of octave or $1/3^{th}$ octave bands is obtained by computing the total acoustic energy of the signal inside this particular frequency band. Such energy is computed using an integration operation on the acoustic energy, which is a quadratic value, over the considered frequency band :

$$L_q[f_{min}, f_{max}] = \int_{f_{min}}^{f_{max}} q^2 df \quad (19.4)$$

The displayed result is a histogram plot, representing these energy values for each of the bands as a bar. By extension, band-averaged signals are generally obtained by integrating quadratic values over frequency bands. To do so, PLTVIEWER applies different recipes depending on the type of data. The integration operation will be performed for each type, the only difference will be a data-conversion

operation (or not) before and after the integration procedure. Four different scenarios are possible :

- Data type is f : octave operations are not allowed on undefined data type. An error message will be displayed, inviting the user to first use *FORCE_TYPE* operator to assign the right type to the data ,
- Data type is l or q : no data-conversion will be performed, the integration operation will be performed directly on the data :

$$\langle q \rangle_i = \int_{f_{min_i}}^{f_{max_i}} q df \quad (19.5)$$

where:

- q is the quantity
 - i is the octave band id
 - f_{min_i} and f_{max_i} are respectively the minimum and maximum frequency of the octave band i
- Data type is dB :

- A pressure quantity is expressed in dB units as :

$$p_{dB} = 10 \log \left(\frac{p^2}{p_{ref}^2} \right) \quad (19.6)$$

where:

- * p is the pressure amplitude
 - * p_{ref} is the reference pressure
- A power quantity is expressed in dB units as :

$$W_{dB} = 10 \log \left(\frac{W}{W_{ref}} \right) \quad (19.7)$$

where:

- * W is the power
- * W_{ref} is the reference power

The octave band quantity is computed as follows :

$$\langle X_{dB} \rangle_i = 10 \log \left(\int_{f_{\min i}}^{f_{\max i}} 10^{\frac{X_{dB}}{10}} df \right) \quad (19.8)$$

where X is p or W .

- When X is a pressure, using the Eq. (19.6), the expression becomes :

$$\langle p_{dB} \rangle_i = 10 \log \left(\int_{f_{\min i}}^{f_{\max i}} \frac{p^2}{p_{ref}^2} df \right) \quad (19.9)$$

- When X is a power, using the Eq. (19.7), the expression becomes :

$$\langle W_{dB} \rangle_i = 10 \log \left(\int_{f_{\min i}}^{f_{\max i}} \frac{W}{W_{ref}} df \right) \quad (19.10)$$

- Data type is TL : the transmission loss is defined as :

$$TL = 10 \log \left(\frac{W_{in}}{W_{tr}} \right) \quad (19.11)$$

where:

- W_{in} is the incident power
- W_{tr} is the transmitted power

The octave band quantity is computed as follows (using Eq. (19.11)) :

$$\langle TL \rangle_i = 10 \log \left(\int_{f_{\min i}}^{f_{\max i}} 10^{\frac{-TL}{10}} df \right) \quad (19.12)$$

$$= -10 \log \left(\frac{\int_{f_{\min i}}^{f_{\max i}} W_{tr} df}{\int_{f_{\min i}}^{f_{\max i}} W_{in} df} \right) \quad (19.13)$$

$$= -10 \log \left(\frac{\langle W_{tr} \rangle_i}{\langle W_{in} \rangle_i} \right) \quad (19.14)$$

This definition is equivalent to the following one only if the incident power is assumed constant ($W_{in} = c^{te}$):

$$\langle TL \rangle_i = 10 \log \left(\frac{W_{in}}{\langle W_{tr} \rangle_i} \right) = 10 \log \left(\frac{\langle W_{in} \rangle_i}{\langle W_{tr} \rangle_i} \right) \quad (19.15)$$

Import remark : as indicated above, functions with l or q data type will be simply integrated, without any pre- or post-operation on the data. This does not correspond to the definition of octave band value as stated by Eq. (19.4). To ensure the use of the proper definition, the data should be converted first to dB units, and tagged with dB data type using `FORCE_TYPE` operator by the user.

19.4.3 Mean octave formulations in PLTVIEWER

In mean octave computation, the integrated value is simply divided by the size of the frequency band, so that the energy is represented by the surface of the bar and comparison with narrow band results is easier. Note that for *TL* data types, since the integration operation is done separately on the numerator and the denominator of the ratio $\frac{W_{in}}{W_{tr}}$, the division by the frequency band size simplifies to 1. All other operations are exactly the same as for octave band computation.

Reconsidering the four different possible scenarios from the previous sub-section, but this time focusing on pressure and power quantities instead of general quantity q :

- Data type is f : octave operations are not allowed on undefined data type. An error message will be displayed, inviting the user to first use *FORCE_TYPE* operator to assign the right type to the data ,
- Data type is l or q : no data-conversion will be performed, the integration operation will be performed directly on the data :

$$\langle q \rangle_i = \frac{1}{f_{max_i} - f_{min_i}} \int_{f_{min_i}}^{f_{max_i}} q df \quad (19.16)$$

where:

- q is the quantity
- i is the octave band id
- f_{min_i} and f_{max_i} are respectively the minimum and maximum frequency of the octave band i
- Data type is dB :
 - A pressure quantity is expressed in dB units as :

$$p_{dB} = 10 \log \left(\frac{p^2}{p_{ref}^2} \right) \quad (19.17)$$

where:

- * p is the pressure amplitude
- * p_{ref} is the reference pressure

- A power quantity is expressed in dB units as :

$$W_{dB} = 10 \log \left(\frac{W}{W_{ref}} \right) \quad (19.18)$$

where:

- * W is the power
- * W_{ref} is the reference power

The mean octave band quantity is computed as follows :

$$\langle X_{dB} \rangle_i = 10 \log \left(\frac{1}{f_{max_i} - f_{min_i}} \int_{f_{min_i}}^{f_{max_i}} 10^{\frac{X_{dB}}{10}} df \right) \quad (19.19)$$

where X is p or W .

- When X is a pressure, using the Eq. (19.17), the expression becomes :

$$\langle p_{dB} \rangle_i = 10 \log \left(\frac{1}{f_{max_i} - f_{min_i}} \int_{f_{min_i}}^{f_{max_i}} \frac{p^2}{p_{ref}^2} df \right) \quad (19.20)$$

- When X is a power, using the Eq. (19.18), the expression becomes :

$$\langle W_{dB} \rangle_i = 10 \log \left(\frac{1}{f_{max_i} - f_{min_i}} \int_{f_{min_i}}^{f_{max_i}} \frac{W}{W_{ref}} df \right) \quad (19.21)$$

- Data type is TL : the transmission loss is defined as :

$$TL = 10 \log \left(\frac{W_{in}}{W_{tr}} \right) \quad (19.22)$$

where:

- W_{in} is the incident power
- W_{tr} is the transmitted power

The mean octave band quantity is computed as follows (using Eq. (19.22)) :

$$\langle TL \rangle_i = -10 \log \left(\int_{f_{min_i}}^{f_{max_i}} 10^{\frac{-TL}{10}} df \right) \quad (19.23)$$

$$= -10 \log \left(\int_{f_{min_i}}^{f_{max_i}} \frac{W_{tr}}{W_{in}} df \right) \quad (19.24)$$

$$= -10 \log \left(\left\langle \frac{W_{tr}}{W_{in}} \right\rangle_i \right) \quad (19.25)$$

As TL is an adimensional quantity, there is no division by the frequency band remaining.

This definition is equivalent to the following one only if the incident power is assumed constant ($W_{in} = c^{te}$):

$$\langle TL \rangle_i = 10 \log \left(\frac{W_{in}}{\langle W_{tr} \rangle_i} \right) = 10 \log \left(\frac{\langle W_{in} \rangle_i}{\langle W_{tr} \rangle_i} \right) \quad (19.26)$$

From the previous relations, it should be noted that for TL data type the mean octave quantities are equivalent to the octave quantities.

PLTVIEWER Render Window

20.1 Introduction

The render Window is used to plot the functions defined in the function panel. This panel is organized in 3 sub-panels:

- Figure panel;
- Figure Properties panel;
- Curve panel.



Figure 20.1: Visualization of the render window.

20.2 Handling functions to plot

To plot a function from the function panel (see Section 19), the plot/update button should be clicked. A new curve is then added within the current *active* figure (see Figure 20.2).

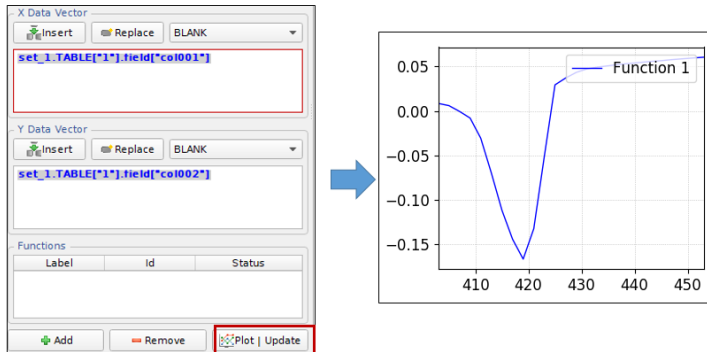

Figure 20.2: Creation of a curve from the function panel.

When a function is modified within the function panel, the corresponding curve is updated within the current *active* figure. A same function can be present in different figures at the same time.

20.3 Curves

Each curve that is present within the current *active* figure is represented by a line in the curve panel while different parameters can be modified.

For each curve, the corresponding function is indicated, and various options can be edited:

- The visualization of the curve can be disabled or enabled;
- Curve position (modify curve position in the legend);
- Line type (solid, dashed, dotted, mix);
- Line color;
- A marker can be added;
- Marker color;
- Marker step;

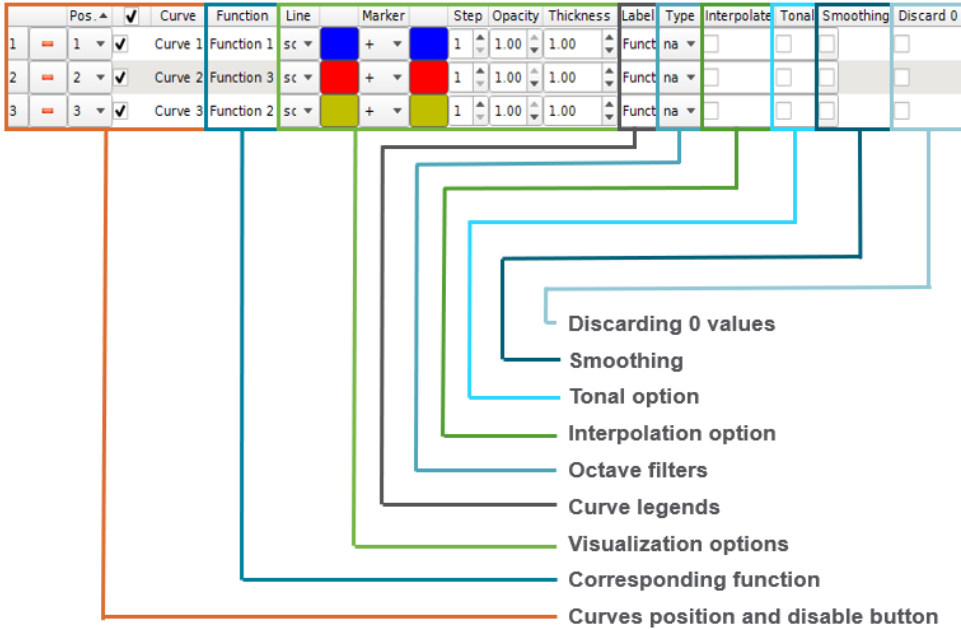

Figure 20.3: Properties of different curves.

- Curve opacity;
- Curve thickness;
- Curve label;
- Octave filters;
- Interpolation of non computed values;
- Tonal signal;
- Smoothing;
- Discard 0 values

Some curves properties are described hereunder.

20.3.1 Octave Filters

The octave filters allow visualizing the plotted functions in narrow band, octave band, 1/3rd octave band, 1/6th octave band, 1/12th octave band and 1/24th octave band. These filters allow considering a tonal signal (filters octave, 1/3

octave, 1/6 octave, 1/12 octave and 1/24 octave) or a continuous signal (filters mean octave, mean 1/3 octave, mean 1/6 octave, mean 1/12 octave and mean 1/24 octave).

The filters octave, 1/3 octave, 1/6 octave, 1/12 octave and 1/24 octave integrates the narrow band curve respectively on each octave band, 1/3rd octave band, 1/6th octave band, 1/12th octave band and 1/24th octave band.

The filters mean octave, mean 1/3 octave, mean 1/6 octave, mean 1/12 octave and mean 1/24 octave also integrate the narrow band curve but then divide the result by the frequency bandwidth of each band.

These filters are available for most of the functions even if the integration method depends on the quantity type:

- linear and quadratic (i.e. amplitude of pressure, real part of radiated power) functions are simply integrated;
- dB and TL functions are translated to a linear or quadratic formulation first, then integrated and finally translated back to dB scale. The integration is thus performed upstream of the dB scale adjustment. Please refer to the Section 20.5) for further details;
- others arbitrary functions tagged as f (undefined) is not plotted and a message informing the user pops up.

The PLT functions are automatically tagged (l for linear, q for quadratic, dB for dB units) according to the quantity type. All others unknown functions are tagged f. A special function FORCE_TYPE allows to manually tag a function. Please refer to the Section 20.5) for further details.

20.3.2 Discard Value Function

If the PLT file contains zero values at some frequencies (e.g.: multiple load computation), activation of the `discard 0` option forces PLTVIEWER to skip those datapoints while plotting the curve. Similarly, NaN values available in the PLT file can be discarded using `discard NaN` option.

20.3.3 Tonal Function

When working with tonal signals, only discrete values at some isolated frequencies are available. Instead of computing the octave (or 1/3 octave) integration in the regular way (and so interpolating between data points), the activation of the `tonal` option makes the assumption of null values between discrete data points and transforms the integral of p^2 into a sum.

20.3.4 Smoothing

The smoothing function is used to obtain a smooth curve when working with octave bands, 1/3rd octave bands, 1/6th octave bands, 1/12th octave bands or 1/24th octave bands. Ticking this box changes the usual rectangular shape of an octave band to an averaged narrow curve. Instead of having a constant value in-between each frequency band boundaries, the smoothing function plots this value at the central frequency of each band.

20.3.5 Discard 0

The Discard 0 option should be used to automatically filter points that have 0 value on the Y axis. It has no effect on envelope curves.

20.4 Figures

The PLTVIEWER allows plotting various results on different figures. By default, one figure is always created at the start of the PLTVIEWER. Additional figures might be created using the menu tab (see Figure 20.4). When creating a new figure, it may be empty (select the *new* button) or a duplicate of the current selected figure (use the *Duplicate current* button).

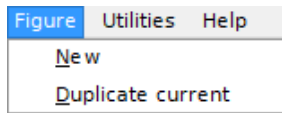

Figure 20.4: Menu tab for creating new figures

Toggling between the different figures is made by selecting the header of the desired figures (see Figure 20.5). The curve panel and figure properties being independent for all figures, these are updated following the *active* figure. Removing a figure is made by clicking on the red cross on its header.

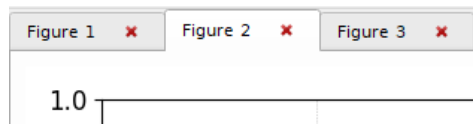

Figure 20.5: Toggling between various figures

Below each figure, the control bar (see Figure 20.6) is used to perform the following operations (ordered according to the buttons from left to right in the control bar):

- home : zoom out to fit all curves data in the figure.
- save the figure in various image file format such as png or eps (see Figure 20.7).
- copy to clipboard allows to perform a snapshot of the displayed figure
- export allows to output figure quantities in txt or csv formats



Figure 20.6: Figure Control Bar

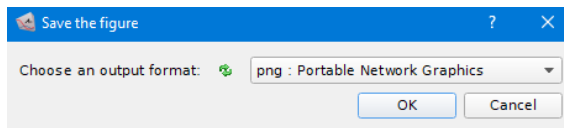

Figure 20.7: Figure Save option

To pan the view, press the middle mouse button and drag. To zoom the view, roll the wheel mouse button. To zoom the view on a selection, press the right mouse button and draw a rectangle. More help is available from the Help->Controls menu.

In addition, each figure has various options which may be edited independently:

- Labels for each axis and a main title;
- The limits of the X and Y axis can be edited or reset; Additionally, each axis can be shown in log scale or using a polar plot;
- Grids might be added to the figure. For log scales, additional grids can be added;
- The location of the legend;
- Font size and color within the figure (main title and axis labels);
- Clean the annotations on the figure;

- Global indicators can be displayed. These quantities are relative to the selected curve.

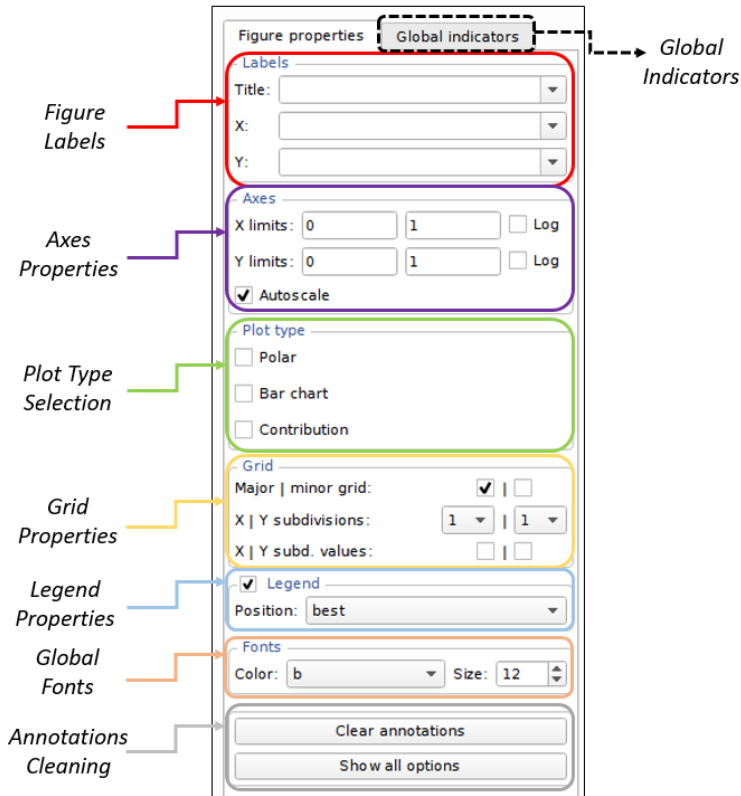

Figure 20.8: Figure properties

20.4.1 Polar plots

Polar plots are often used when requiring the visualization of the acoustic directivity. Its usage is usually combined with the usage of reverse sets (see Section 18.3). The limits of the X axis is automatically set from 0 to 360 in order to visualize polar coordinates. It is then required either to adapt the X data vector, or to have an angular identification of field points. In the following example (Figure 20.9), an array of 360 field points is placed around a radiating quadrupole radiating in free field. By computing a reverse set and visualizing the results in polar coordinates, the directivity of the source is plot.

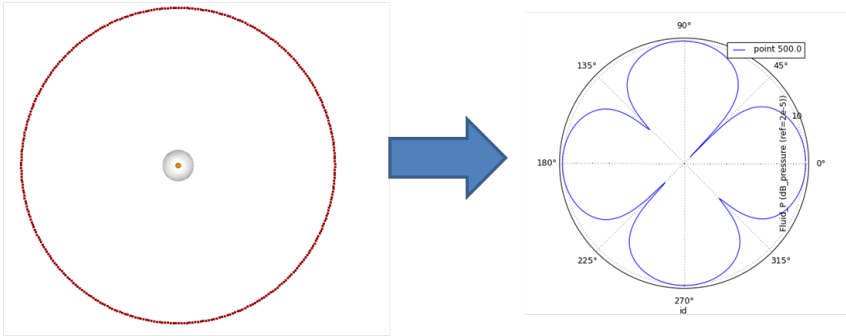

Figure 20.9: Polar plots on a quadripole

20.4.2 Phasor plots

Phasor plots are used to compare the contributions of different microphones, panels, ... This is particularly interesting to detect phase opposition and therefore constructive or destructive interference. The phasor plot can be displayed based on both classical sets (frequency arrays) or by using the reverse set capability (see Section 18.3). The limits of the X axis is automatically set from 0 to 360 in order to represent a complex diagram.

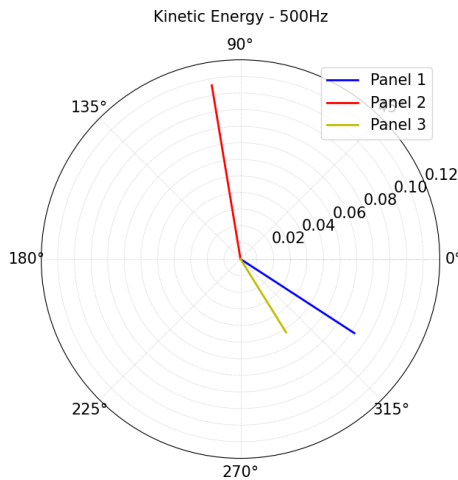

Figure 20.10: Phasor plot

The length of the drawn line represents the amplitude of the quantity, while its orientation in the diagram represents the phase.

To use phasor plot with complex values, no operator should be defined in the Y data vector, as illustrated below.

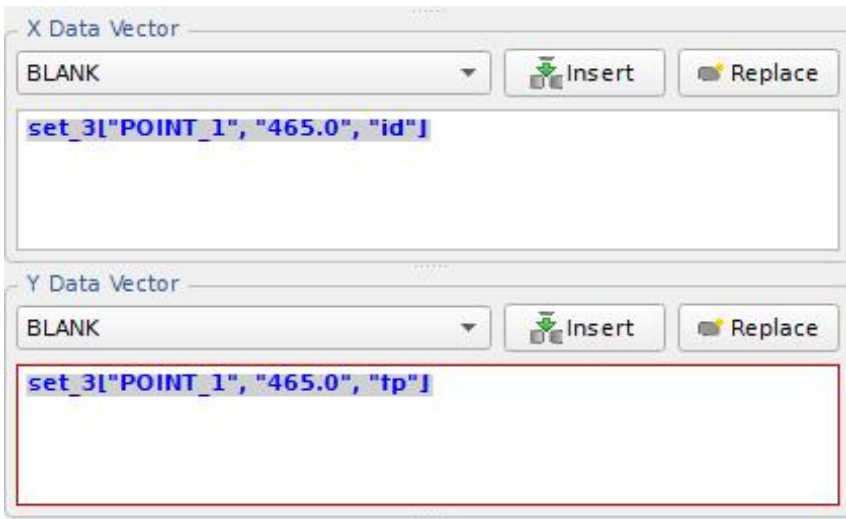

Figure 20.11: Complex values

Note that the phasor plot can also accept quantities specified within `AMPLITUDE` or `dB` operator, but as these operators provide a real value at the end, the plot will display a horizontal line of length equals to the output value, and a phase equals to 0.

20.4.3 Bar Charts

Bar charts plots are available when dealing with $1/x$ octave band results. They allow to visualize results using bar charts instead of solid curves. This visualization is commonly used in the acoustics' world. When activating this option, the curves already displayed in the figure are automatically converted into bar charts. The bar width can be adjusted using an appropriate parameter. Several bar charts can be illustrated together in the same figure.

Note that this plot type option is not supported when dealing with multiple types of $1/x$ bands on the same figure.

In the following example (Figure 20.12), the sound pressure level for two different microphones is illustrated in third octave band using bar charts representation. The experimental results, defined on a different frequency range, are also displayed. The octave center frequencies are displayed on the x axis, and annotations

are added at different locations to directly access to the bar chart values.

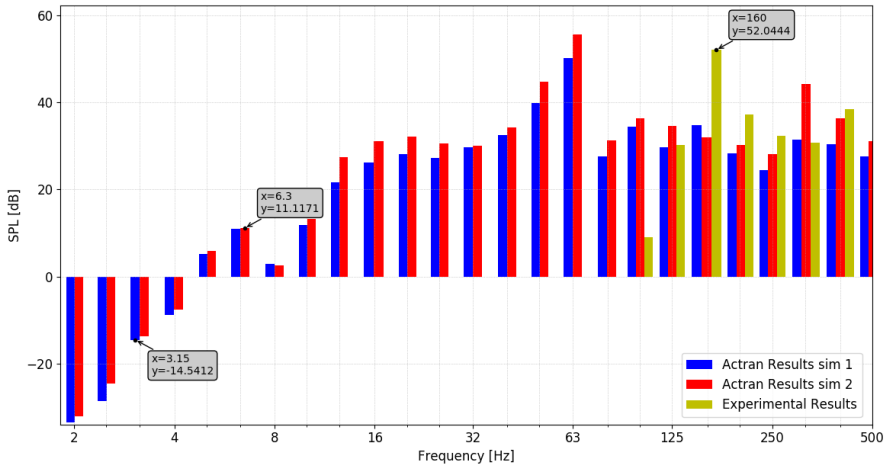

Figure 20.12: Bar Charts Plot

20.4.4 Frequency-wide Indicators

Frequency-wide indicators are defined to quantify the noise level of a sound source on a specific range of frequency. Among them, the *Overall Sound Level* (OSL) is widely used to provide one unique value based on the whole frequency content (see Figure 20.13). This sub-section presents the following indicators :

- OSL
- Integral
- Mean value (Integral / (fmin - fmax))
- RwCCtr
- Max X
- Min Y
- RMS
- RMS PSD
- Loudness

- Sharpness

The OSL acronym stands for Overall Sound Level. This generic formulation can be used with either pressure or power quantities.

According to the quantity type involved the OSL becomes:

- OSPL (*Overall Sound Pressure Level*) for a dB_pressure function;
- OASPL (*Overall A-weighted Sound Pressure Level*) for a dBA_pressure function;
- OSWL (*Overall Sound Power Level*) for a dB_power function;
- OASWL (*Overall A-weighted Sound Power Level*) for a dBA_power function;
- etc ...

The OSPL indicator is computed as:

$$OSL_{dB} = 20 \log \frac{\sqrt{\int_{f_{min}}^{f_{max}} p^2 df}}{p_{ref}} \quad (20.1)$$

whereas the OSWL indicator is given by:

$$OSL_{dB} = 10 \log \frac{\int_{f_{min}}^{f_{max}} W df}{W_{ref}} \quad (20.2)$$

The OSL and OASL are only available for data expressed using dB scale. A warning message is prompted in the legend if this assumption is not fulfilled (e.g.: *OSL : no dB units*). If other curves involving dB scaled data are already displayed on the figure, the OSL is correctly displayed for them.

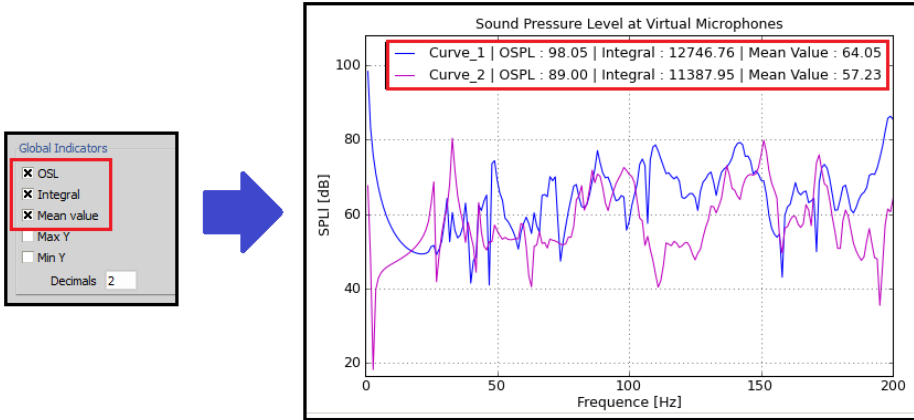

Figure 20.13: OSPL / Integral / Mean Value plots

Alternatively, the RMS, also known as root mean square value, is also widely used. The computation of the RMS value differs depending on the nature of the provided curve. If the curve is provided in dB units, as for the OSL indicator, the RMS is computed as:

$$RMS_{dB} = 20 \log \frac{\sqrt{\frac{\int_{f_{min}}^{f_{max}} p^2 df}{(f_{max} - f_{min})}}}{p_{ref}} \quad (20.3)$$

For a linear quantity V , the RMS indicator is computed as:

$$RMS_V = \sqrt{\frac{1}{f_{max} - f_{min}} \int_{f_{min}}^{f_{max}} V^2(f) df} \quad (20.4)$$

while for a quadratic quantity:

$$RMS_V = \frac{1}{f_{max} - f_{min}} \int_{f_{min}}^{f_{max}} V(f) df \quad (20.5)$$

which is equal to the computed mean value indicator.

The second root mean square value, named RMS_PSD differs for the computation of quadratic quantities:

$$RMS_V = \sqrt{\int_{f_{min}}^{f_{max}} V(f)df} \quad (20.6)$$

Loudness and sharpness are the psychoacoustic parameters enabling to analyse the sound quality with regard to the perception of human ear.

Loudness describes the magnitude of an auditory sensation. The loudness in ACTRAN is calculated according to DIN 45631 (ISO 532B) standards (Zwicker model) for stationary sound and measured in sone. A loudness of 1 sone is equivalent to a sine tone of the frequency 1kHz presented at level of 40dB. Sones are linear quantities, so a doubled loudness on the loudness scale corresponds to a doubled sone value.

The total loudness N is computed as the integral of the specific loudness N' , measured in sone/bark, over the critical bands (subdivision of audible frequency range into Bark scale ranging from 0 to 24 Bark). The values of specific loudness are evaluated from third octave band levels as function of critical band rate in Bark.

$$N = \int_0^{24Bark} N' dz \quad (20.7)$$

where z is the critical band rate (measured in Bark).

Sharpness is a measure of the high frequency content of a sound. It is increased by adding higher frequency content, and decreased by adding lower frequency content. The unit of sharpness is acum. A narrow band noise one critical band wide centered on 1kHz having a level of 60dB produces the sharpness of 1 acum. In ACTRAN the sharpness is calculated with the weighting function $g(z)$ employed by Zwicker E. and Fastl H., 'Psychoacoustics: Facts and Models (Springer 1990)'.

$$S = 0.11 \frac{\int_0^{24Bark} N' g(z) dz}{\int_0^{24Bark} N' dz} \quad (20.8)$$

All these frequency-wide indicators can be exported in a text file using the buttons `Export Selected Indicators` and `Export All Indicators`.

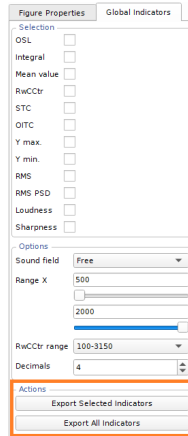

Figure 20.14: Export OSL

20.5 Remarks and Further Reading

Arrays of data can be of the following types in PLTVIEWER :

1. linear such as the pressure, displacement, ...
2. quadratic such as the radiated power, dissipated power, ...
3. dB or logarithmic such as dB pressure, dB power, ...
4. TL for transmission loss index
5. arbitrary when the data is computed based on a mathematical expression introduced in PLTVIEWER

Internally, each function is tagged with one of these types. This tag is used to post-process the data such as octave bands plots. The dB tag contains one additional information about the reference chosen in the logarithmic expression.

One can manually define the type of a function using the following function:

```
FORCE_TYPE(data, type, [ref])
```

where data is the data array related to the tag to be changed, type is the plt_type (1: linear; q: quadratic, dB: $10 \cdot \log_{10}(x)$, TL: $10 \cdot \log_{10}(1/x)$, f: arbitrary function,

unknown behavior for a correct integration), `ref` is the reference value for dB scale (optional).

PLT imported values are tagged (l, q, dB or f) according to their designation. However, multi-columns quantities imported from TXT file are tagged l (linear) by default. It is the responsibility of the user to use the `FORCE_TYPE` operator if, for instance, the imported values rely on a dB scale. A typical example is highlighted underneath Figure 20.15.

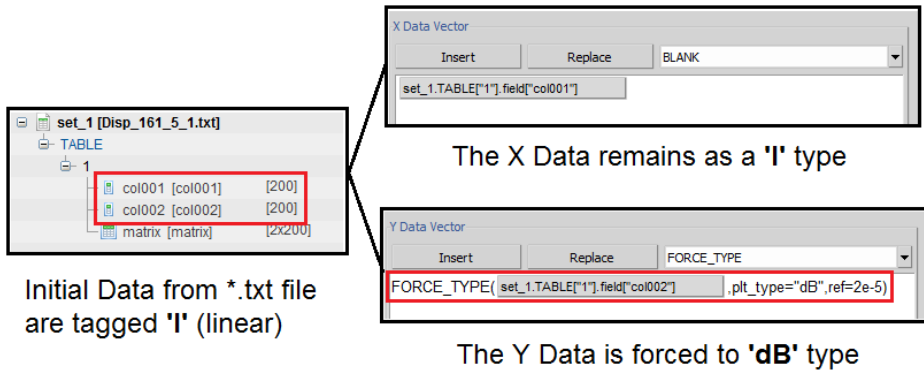

Figure 20.15: Modification of the data type from an experimental .txt results file

TL quantity is correctly integrated (octave and 1/3 octave) as long as incident/incoming power/intensity is constant (which is most of the time). If it is not the case, the results are incorrect and no warning is issued (as it is undetectable using the tag formalism).

PLTVIEWER Sound Quality Metrics

21.1 Introduction

The human ear is receptive to sound frequency, level and duration, and the combination of these properties with the human ear's characteristics allow to define perception models. Sound Quality metrics specifically allow a linear representation of human hearing perception. They are defined during psychoacoustic studies that establish a correlation between our ear operation and the feeling a sound convey. In ACTRAN 5 sound quality metrics are available to analyze stationary and time-varying signals:

- Bark scale;
- Loudness (ISO 532B);
- Sharpness (DIN 45692);
- Roughness (Daniel and Weber);
- Tonality (ECMA 74);
- Speech Intelligibility Index (ANSI S3.5);

21.2 Bark scale

The human ear is receptive to sounds from 20Hz to 20kHz, but the frequency detection accuracy is variable along this range: the higher two sounds are, the less the human ear is able to distinguish them. For instance, an ontologically normal listener can detect the difference between 450 Hz and 500 Hz, but not between 6000 Hz and 6050 Hz.

Thus, some frequency bands are defined so that two frequencies in the same band can not be distinguished. The Bark scale includes 24 "critical bands" on which an equal distance corresponds to an equal frequency perception. This scale is frequently used to present psychoacoustic results since it is a human-coherent representation of the frequency axis.

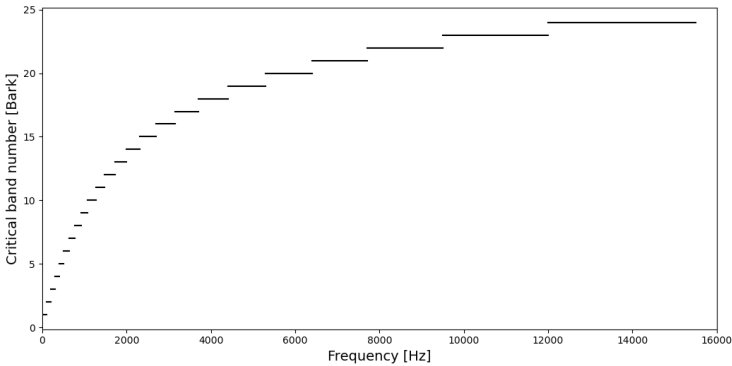

Figure 21.1: 24 critical bands with increasing width.

21.3 Loudness (ISO 532B)

Loudness describes the magnitude of an auditory sensation. The loudness in ACTRAN is calculated according to ISO 532B standard following the Zwicker model measured in sone. A loudness of 1 sone is equivalent to a sine tone of the frequency 1kHz presented at level of 40dB. Sones are linear quantities, so a doubled loudness on the loudness scale corresponds to a doubled sone value, that is to say a sound perceived as twice louder.

The total loudness N is computed as the integral of the specific loudness N' measured in sone/bark, over the Bark scale. The values of specific loudness are evaluated from third octave band levels as function of critical band rate z in Bark.

$$N = \int_0^{24\text{Bark}} N' dz \quad (21.1)$$

21.4 Sharpness (DIN 45692)

Sharpness is a measure of the high frequency content of a sound. It is increased by adding higher frequency content, and decreased by adding lower frequency

content. The unit of sharpness is acum. A narrow band noise one critical band wide centered on 1kHz having a level of 60dB produces the sharpness of 1 acum. In ACTRAN the sharpness is calculated according to DIN 45692 standard. It consists of a specific loudness weighting employing Zwicker E. and Fastl H. weighting function $g(z)$.

$$S = 0.11 \frac{\int_0^{24\text{Bark}} N' g(z) dz}{\int_0^{24\text{Bark}} N' dz} \quad (21.2)$$

21.5 Roughness (Daniel and Weber)

Roughness is an indicator of the modulation degree in a sound. Modulation is a magnitude or frequency periodic variation of the signal along time. Roughness combines the modulation frequency, the modulation index and the carrier frequency to define 47 specific values along the Bark scale that are then summed to get the global value.

$$R = 0.25 \sum_{i=1}^{47} R'_i \quad (21.3)$$

Its unit is the asper, 1 asper corresponding to a 60 dB 1 kHz sine modulated at 70 Hz. Above 300 variations per second, the human ear is no longer able to detect the modulation phenomenon. The computation available in Actran relies on Daniel and Weber model, described in *Psychoacoustical roughness: implementation of an optimized model*, *Acustica acta.acustica* published in 1997.

21.6 Tone-to-Noise Ratio / Prominence Ratio (ECMA 74)

A sound composed of a single frequency is called a tone. Sounds can be either pure tones or complex sounds composed of multiple tones. Tone-to-Noise Ratio (TNR) and Prominence Ratio (PR) are two tonality models describing the prominence of tonal components in a sound. Their computations follow the same principle with a spectrum analysis detecting peaks to be compared with the smoothed spectrum.

$$\Delta L_{TNR} = L_{peak} - 10\log(10^{0.1L_{peak\ band}} - 10^{0.1L_{peak}}) + \epsilon$$

$$\Delta L_{PR} = 10\log(10^{0.1L_{peak\ band}}) - 10\log[0.5(10^{0.1L_{lower\ band}} + 10^{0.1L_{upper\ band}})] \quad (21.4)$$

According to ECMA 74, TNR can prove to be more accurate for multiple tones in adjacent critical bands, for example when strong harmonics exist. PR can be more effective for multiple tones within the same critical band and is more readily automated to handle such cases. Along with the TNR and PR value comes a prominence indicator, a tone being considered as prominent if its dB level is sufficiently higher than the smoothed spectrum, depending on its frequency.

21.7 Speech Intelligibility Index (ANSI S3.5)

The Speech Intelligibility Index (SII) measures how well a speech is comprehensible under a variety of adverse listening conditions. The computation method has been standardized in ANSI S3.5 (1997). It is computed from measurements or estimates of speech spectrum level, noise spectrum level, and from psychoacoustical measurements or estimates of hearing threshold level. By measuring the speech-to-noise ratio in each contributing frequency band A_i and weighting the results with an importance function I_i , the intelligibility of a speech communication system can be predicted.

$$SII = \sum_{i=1}^n I_i A_i \quad (21.5)$$

Part IV

WATERFALLVIEWER Reference Guide

WATERFALLVIEWER Overview

22.1 Introduction

The WATERFALLVIEWER is the graphical tool to display ACTRAN results under the form of waterfall diagram.

The main components of the WATERFALLVIEWER User Interface are listed below (see Figure 22.2):

1. **Menu:** Menu gives access to the main functionalities of the WATERFALLVIEWER tool.
2. **Data Tree Panel:** Every imported PLT, UNV, MDF, PUNCH or TXT file is parsed and subdivided by its different quantities. The data tree panel shows the different available quantities by results type/loadcase;
3. **Function Panel:** Every diagram is defined by a function. These X-Y-Z functions can refer to results available in the Data Tree Panel (using certain operators), and respect the Python syntax. Built-in functions are also available. Please refer to Chapter 25 for more details;
4. **Render Window:** WATERFALLVIEWER is designed to create waterfall diagrams. Each diagram is defined based on a three variables function defined in the Function panel. 2D-curves can be defined based on the waterfall diagram by cutting it vertically or horizontally. Please refer to Chapter 26 for more details.

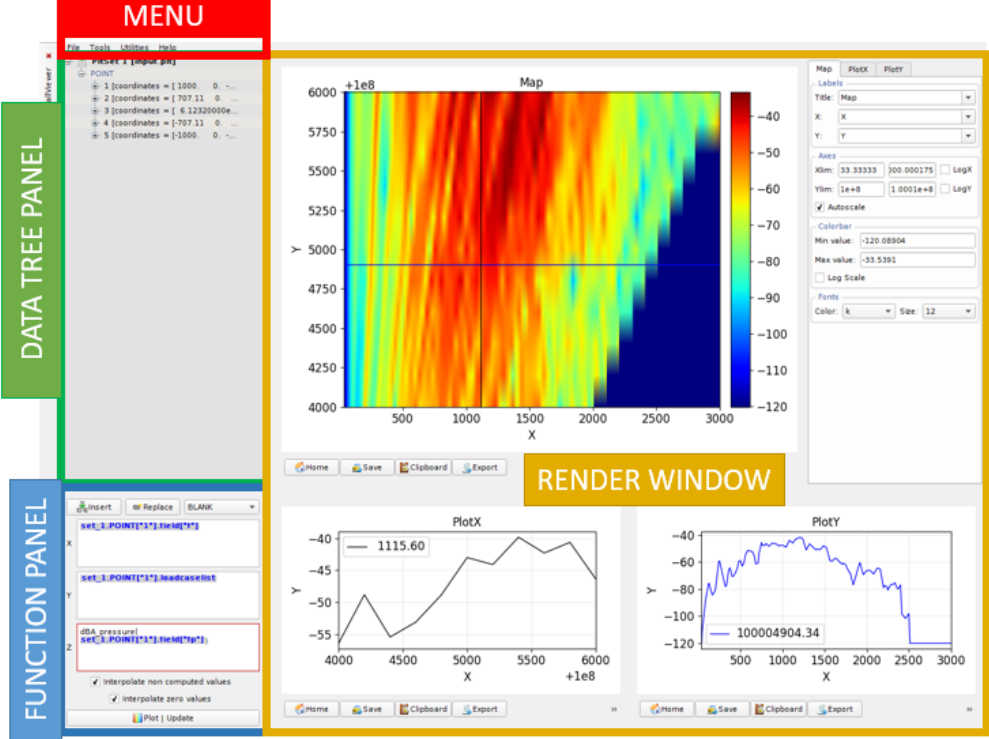

Figure 22.1: Global layout of the Waterfall Viewer.

22.2 Launching the WATERFALLVIEWER

Multiple ways are available for launching the WATERFALLVIEWER

1. The WATERFALLVIEWER can immediately be accessed from ACTRAN VI through the toolbar (Tools→PLTViewer).

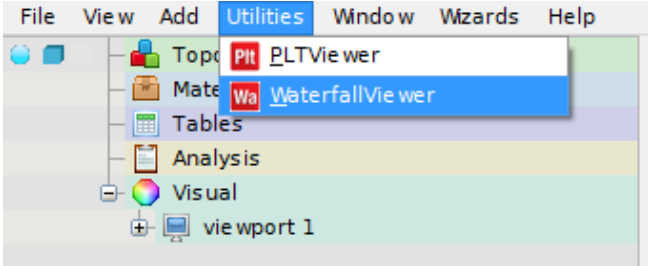

Figure 22.2: Launching WaterfallViewer from ACTRAN VI.

2. WATERFALLVIEWER can be launched from the prompt by typing the command:

```
actran -u WaterfallViewer [-n|--no_render] [-x|--execute] ...  
[-i|--import_file] [-b|--background]
```

where

- n, --no_render : WATERFALLVIEWER will be launched without rendering window (batch mode);
 - b, --background : WATERFALLVIEWER will be launched in background mode;
 - x, --execute= : the execution of the specified WATERFALLVIEWER script will be performed;
 - i, --import_file= : the specified result file will be imported.
3. On Windows, the WATERFALLVIEWER can be launched by double-clicking on the shortcut located in the START menu.

Trace files and session files are systematically created and contains respectively all software information and the different operation performed within the WATERFALLVIEWER. The session file can be re-used as explained in Chapter 27.

WATERFALLVIEWER Menu

23.1 "File" menu

The File menu of WATERFALLVIEWER allows performing global actions. These actions are gathered in four groups:

1. Load or Export session file (see Section [23.1.1](#))
2. Import results (see Section [23.1.2](#))
3. Export waterfall data to TXT or CSV files (see Section [23.1.3](#))
4. Modify the WATERFALLVIEWER settings (see Section [23.1.4](#))

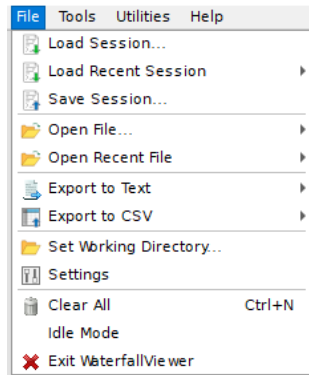

Figure 23.1: Menu of the Waterfall Viewer.

23.1.1 Scripting and Session Files

Like for ACTRANVI an API (Application Programmer Interface) is available for WATERFALLVIEWER in order to write and read WATERFALLVIEWER commands in a session file. When opening the WATERFALLVIEWER, a session file is automatically created. Such file can for instance be used for:

- Re-launching WATERFALLVIEWER in the latest state;
- Retrieving a stable status of the WATERFALLVIEWER when a crash appears (by suppressing different lines for instance);
- Re-using a post-processing procedure on a different set of results;
- Automating the post-processing operations in an industrialization phase of ACTRAN.

The current script file is automatically indented with the operated commands within the WATERFALLVIEWER, written in the python format (www.python.org). Every available command within the WATERFALLVIEWER can be accessed through this API. The different available functions and options are described in Section 27.

23.1.2 Importing Results in WATERFALLVIEWER

The WATERFALLVIEWER supports the following results file:

- PLT (ACTRAN result file);
- TXT (ASCII column files)
- UNV (IDEAS Universal; data block type 58)
- PUNCH (NASTRAN punch file).

When importing a plt file, a plt set is created and shows all its content in the data tree panel (see Section 24). The leaves of the tree are vectors of data and can be used to create functions.

Text files with columns formatted data (see below) can also be imported.

0	5.02e-6	5.4
1	4.52e-6	3
2	5.21e-6	6

23.1.3 Exporting Results from WATERFALLVIEWER

This option allows to export the data of the visible waterfall diagram to TXT or CSV files. Three files are generated :

1. **filename_x.txt** contains x coordinates of the waterfall diagram
2. **filename_y.txt** contains y coordinates of the waterfall diagram
3. **filename.txt** contains the matrix of all values associated to (x,y) coordinates

23.1.4 Settings

The general settings of WATERFALLVIEWER can be access in order to:

- Select a folder containing all the user's scripts written for specific post-processing operations.
- Choose either or not a confirmation is required for several actions (clear all, ...).
- Choose to overwrite or not the session file created the last time you opened WATERFALLVIEWER. If this option is unchecked, a unique session file is created each time you launch the application.

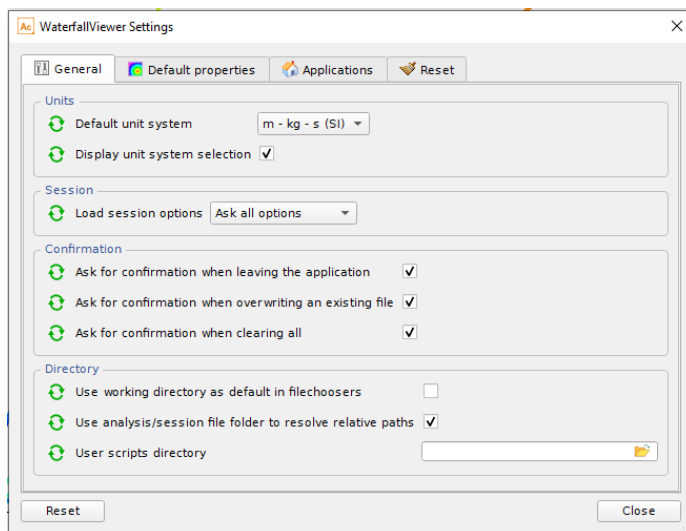

Figure 23.2: General Settings of the Waterfall Viewer.

Default properties as the reference value for dB plots or general font sizes and colors can also be modified to fulfill the needs of the user.

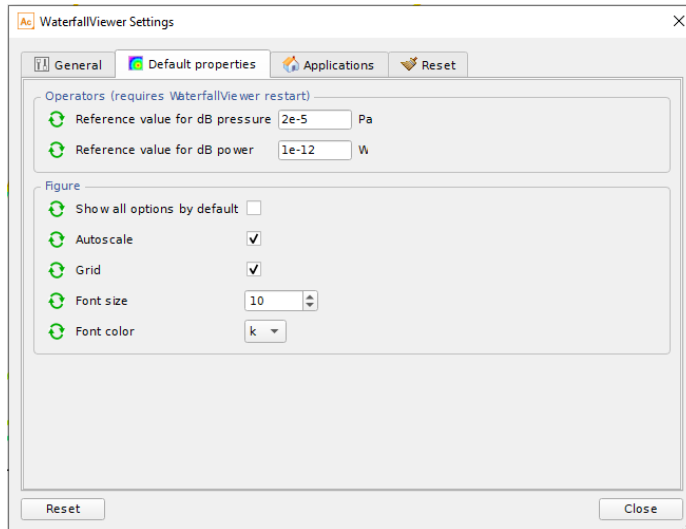

Figure 23.3: Default Properties of the Waterfall Viewer.

23.2 "Tools" menu

The WATERFALLVIEWER includes different dedicated tools:

1. A tool to compute MAC correlations between modal extractions and or measurements (see Section 23.2.1)
2. A tool to evaluate participation factor of a structural modal basis based on measurements (see Section 23.2.2)
3. A tool to automatically generate cuts corresponding to different engine orders (see Section 23.2.3)
4. A tool to display acoustic results as Spectrogram plot (see Section ??)
5. A tool to combine acoustic results with realistic excitations provided in time domain (see Section 23.2.5)
6. A tool to convert RPM based modal participation factors to Order-based modal participation factors (see Section 23.2.6)
7. A tool to evaluate engine sources based on measurements and recombine these with transfer functions (see Section 23.2.7)

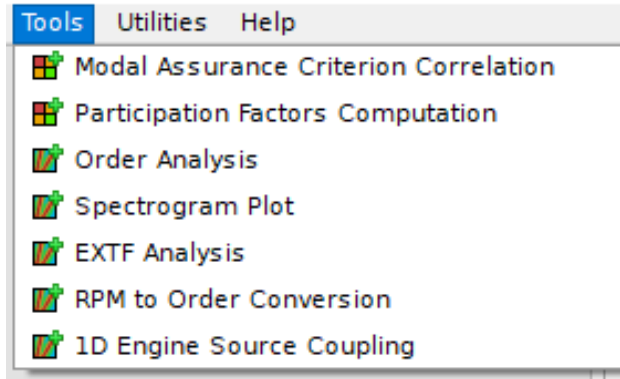

Figure 23.4: Tools Menu of the Waterfall Viewer.

23.2.1 MAC Correlation

The Modal Assurance Criterion correlation (or MAC correlation) is a criterion used to compare the shape of structural modes.

This feature could interest all our customers that use ACTRAN , NASTRAN or experiment measurements for structural analysis in order to:

- Compare modal extractions
- Validate the models
- Optimize the designs

It can be considered as a really useful, advanced feature to post-process the modal results.

Description of the MAC

The Modal Assurance Criterion (MAC) is a direct and objective comparison of specific dynamic properties measured vs measured, measured vs predicted or predicted vs predicted. In this case, a modal comparison is considered.

The MAC correlation is computed as follows:

$$MAC(A, X) = \frac{\left| \sum_{j=1}^n (\psi_X)_j (\psi_A)_j^* \right|^2}{\left(\sum_{j=1}^n (\psi_X)_j (\psi_X)_j^* \right) \cdot \left(\sum_{j=1}^n (\psi_A)_j (\psi_A)_j^* \right)} \quad (23.1)$$

where :

- X et A are the 2 configurations of interest
- ψ_X and ψ_A correspond to the normalized modes
- j is a point of the structure (must be the same for the 2 modes)
- n is the number of points of the structure considered

The MAC(A,X) value is in the range [0,1].

The MAC in ACTRAN

In practice, the number and location of the nodes is not identical for experimental results and for simulation results. In the same way, the nodes between two numerical models can also differ. A correspondence must then be performed to fit the nodes of two configurations. To do so, a projection algorithm is used. The corresponding nodes between the two models are found by projecting both modal databases on a third mesh (which can be different or identical to one of the two first configurations).

Once the projection is made, it is possible to calculate the MAC correlation. One can then output a waterfall diagram comparing the shape of each normalized mode of the first configuration to each normalized mode of the second configuration. It is also possible to export the MAC matrix in an external text file.

The feature supports modes and projection meshes of the following formats:

- UNV (IDEAS Universal)
- OUTPUT2 format produced by NASTRAN or ACTRAN
- NFF database produced by ACTRAN

Computing the MAC correlation

The MAC properties window can be opened through menu Tools → Compute Modal Assurance Criterion correlation (Figure 23.5)

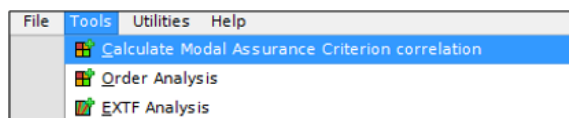

Figure 23.5: Opening the MAC window.

There are several fields as input of the MAC correlation, as shown in figure 23.6

1. The first and second modal databases used for the comparison as well as the type of quantity contained in the databases
2. The geometrical points i.e. the mesh used for the projection. This mesh can either be the one of the first modal database, the mesh of the second modal database or another mesh.
3. Plane and gap tolerance used for projection. Please refer to ACTRAN User's Guide Chapter 37.2 of Volume 1 for more explanation about those two parameters.
4. The frequency range of the MAC correlation. By default, it is the entire frequency range of the modes contained in the modal databases.
5. Selection of 1D modal database. Because sensors are usually unidirectional, experimental modal databases often contains 1D data in local coordinates (e.g. displacement normal to the structure). Because this has a direct impact on the mac result, this must be accounted for. To do so, simply select the modal database containing 1D in the scrolling list.

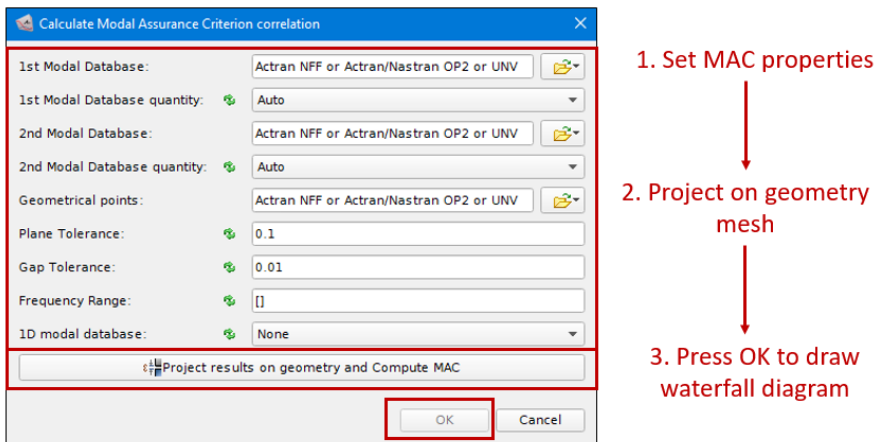

Figure 23.6: Setting MAC options and drawing waterfall diagram.

Then, perform the projection and press "ok" to draw the waterfall diagram. Figure 23.7 shows an example of MAC output. The MAC is calculated by the using twice the same modal database. In this case, the correlation is perfect (1 value on the diagonal, 0 elsewhere).

In presence of big modal databases, it is better to avoid having numerous nodes that do not contain any displacement value. Those nodes will be projected but the default displacement value will be set to 0. As a consequence, they

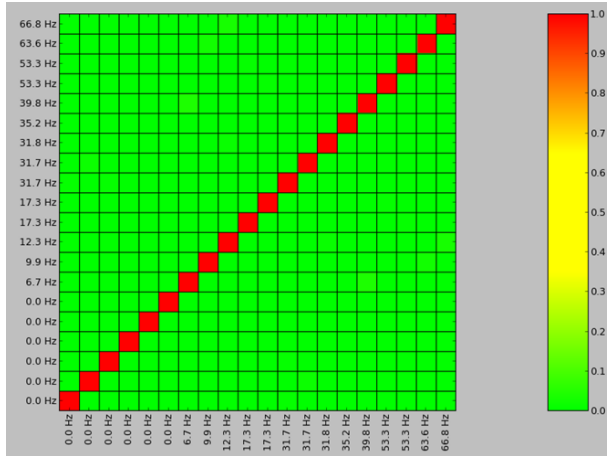

Figure 23.7: Example of MAC output: correlation is perfect in this case.

will not contribute to the MAC correlation in any way. The projection time will then increase unnecessarily. For the same reason it is better to have only geometrical nodes within reach of the modal databases nodes. Those nodes will be processed during the MAC computation, but no node of the modal database will be projected on them.

23.2.2 Participation Factors

The Participation Factors tool in ACTRAN allows to compute the modal participation factors from results and a given database of modes.

This feature is very interesting for acoustic radiation analyses when:

1. The results are available at several points (e.g experimental measurements).
2. The results have been computed by a direct response (e.g modal response was not applicable because of complex structural effects not included in the modal extraction solver : Viscous damping, non homogeneous damping,...).

The Participation Factors tool in ACTRAN allows the number and location of the nodes to differ between the results and the modes. It supports:

- Results available at discrete points (under-defined case).
- Results available on the same points as modes (perfectly defined case).
- Results available at on a mesh finer than the modes (over-defined case).

As for the MAC computation, a projection algorithm is then used. The corresponding nodes between the results and modes are found by projecting both on a third mesh (which can be different or identical to one of the two first configurations). A least square method is then used to compute the participation factors, minimizing the squared error between the corresponding nodes.

The feature supports modes, results and projection meshes of the following formats:

- UNV (IDEAS Universal)
- OUTPUT2 format produced by NASTRAN or ACTRAN
- NFF database produced by ACTRAN

Computing the Participation Factors

The Participation Factors properties window can be opened through menu Tools (Figure 23.8)

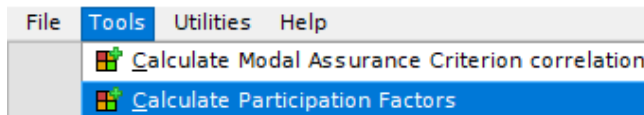

Figure 23.8: Opening the Participation Factors window.

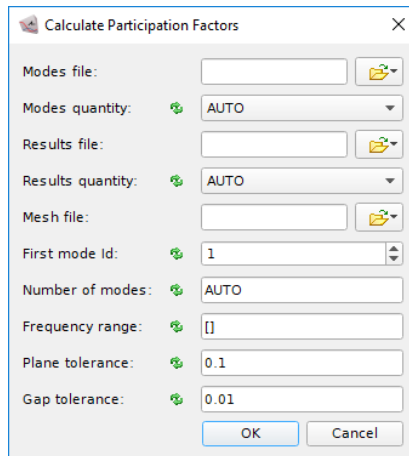

Figure 23.9: Setting Participation Factors options.

There are several fields as input of the Participation Factors computation, as shown in Figure 23.9

1. The modal database used as well as the type of quantity it contains (DISPLACEMENT, MODAL_DISPLACEMENT, PRESSURE or MODAL_PRESSURE). If the AUTO keyword is chosen, ACTRAN will search for one of those two quantities.
2. The result file used as well as the type of quantity it contains (DISPLACEMENT, NORMAL_DISPLACEMENT, ACCELERATION, NORMAL_ACCELERATION, PRESSURE or MODAL_PRESSURE). As for modes, if the keyword AUTO is specified, ACTRAN will search in the result file for one of those quantities. If several quantities are found, ACTRAN will ask to manually select the quantity of interest.
3. The mesh used for the projection. This mesh can either be the one of the modal database, the results or another mesh.
4. The first mode and number of modes to be considered in the modal database for the computation. By default, all modes are considered.
5. The frequency range of the Participation Factors computation. By default, it is the entire frequency range of the results.
6. Plane and gap tolerance used for projection. Please refer to ACTRAN User's Guide Chapter 37.2 of Volume 1 for more explanation about those two parameters.

Press then OK to compute the participation factors. A PLT set will be created containing the factors, and they will be drawn in the waterfall diagram (see Figure 23.10).

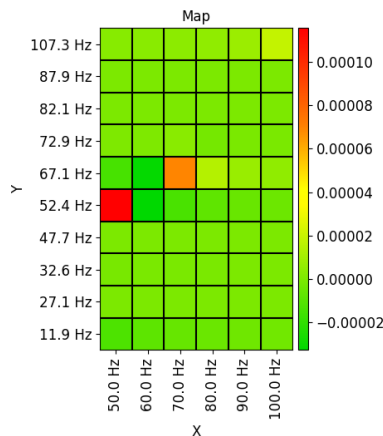

Figure 23.10: Example of Participation Factors.

The participation factors can then be exported in PLT format, by right-clicking on the created set, and exporting it (see Figure 23.11).

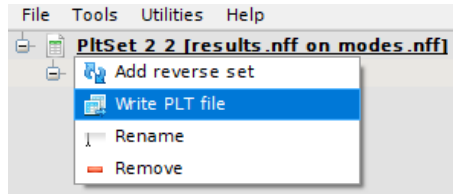

Figure 23.11: Exporting the participation factors.

23.2.3 Order Analysis

In addition to vertical and horizontal cuts, an order analysis can be done to obtain results at particular orders. In this case, one makes the assumption that the x values are corresponding to frequencies expressed in Hz, while the y values are corresponding to the rotation speed expressed in round per minutes. The cut obtained by the order analysis corresponds to the interpolation at line $y = 60 * x / \text{order}$.

The Order Analysis window can be opened through menu Tools → Order Analysis (Figure 23.12).

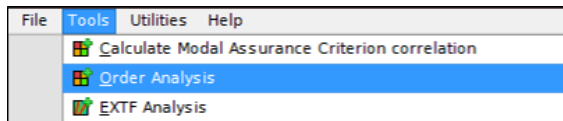

Figure 23.12: Opening the Order Analysis

There are several options for the order analysis, as shown in figure 23.13

1. The list of orders to extract. A single value or a complete list can be provided.
2. The number of interpolation points along the line.
3. The interpolation order of the extracted curve. This can be chosen between linear interpolation, quadratic or cubic interpolation.
4. The X axis that is chosen for the curve extraction. One can plot the order analysis following the rotation speed or the frequency.

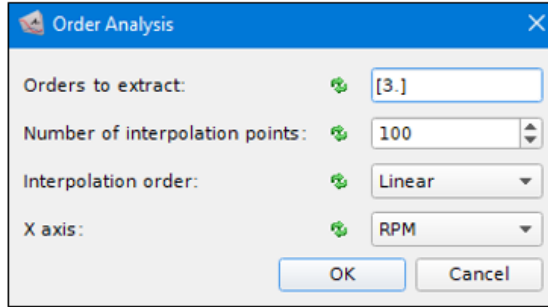

Figure 23.13: Order Analysis options

When performed, diagonal cuts are plotted within the render window, and the order cut is shown in the bottom render window, depending on the selected X axis. Typical result is shown in figure 23.14.

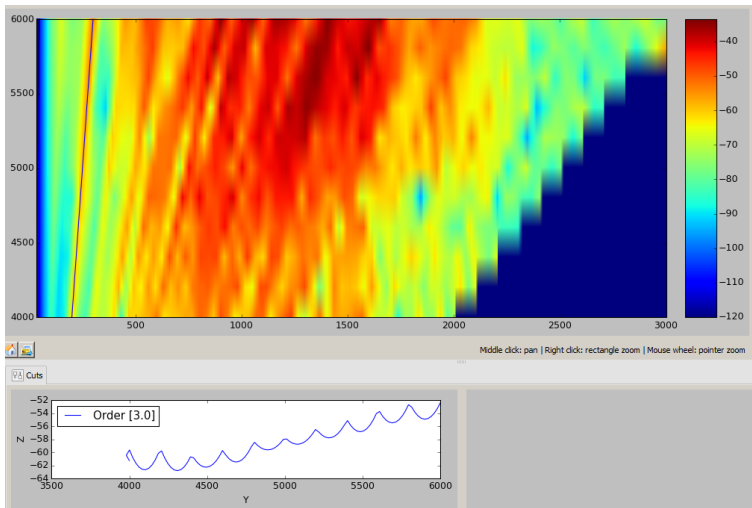

Figure 23.14: Obtained solution

23.2.4 Spectrogram Plot

The Spectrogram Plot tool can be opened through menu Tools → Spectrogram PLOT (Figure 23.15).

Definition

When dealing with ramp-up simulation, acoustic results are obtained at different rotation speeds (RPM). Such results are usually visualized in an "RPM" over

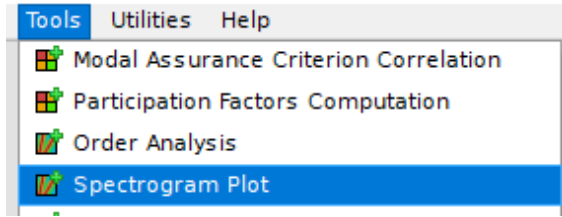

Figure 23.15: Opening Spectrogram Plot tool

"frequency" 2D-graph. Engine orders (ORDER) can be captured as diagonal curves in this graph. RPM, ORDER n and frequency f are linked together as following:

$$f_{n,RPM} = n \frac{RPM}{60} \quad (23.2)$$

RPM or ORDER dependency is handled in ACTRAN through the usage of LOADCASE. Each LOADCASE corresponds to an RPM or ORDER (see section 23.2.4 to know how to specify this information). Due to the evolution of the frequencies with RPM increase, the list of computational frequencies usually differs from an RPM to another. The same happens for an order-based analysis. This leads to multiple PLT files, one per RPM or per ORDER.

A Spectrogram is generally defined as an evolution of audio spectrum over time. In WaterfallViewer it is referring to an evolution of spectrum over RPM for a limited number of orders (Figure 23.16). It differs from a Waterfall plot where a dense matrix of results is considered ($m*n$ matrix).

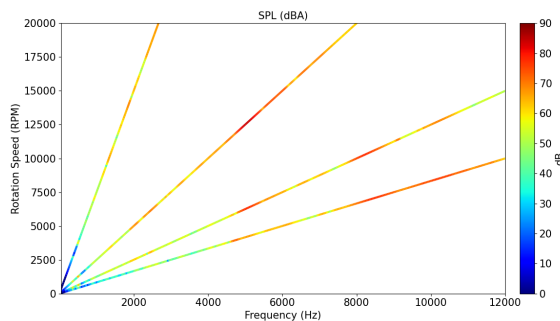

Figure 23.16: Example of Spectrogram Plot

Pre-requirements

Information of RPM or ORDER must be indicated in the LOADCASE_INDEX block of the PLT file(s). The syntax is the following:

- either RPM = *rpm_value*
- or ORDER = *order_value*

This LOADCASE information can be generated in different ways:

- the user can provide the RPM or ORDER value as name of a LOADCASE
- it is filled automatically for an acoustic radiation analysis (BC_MESH) using modal participation factor file generated by "RPM to Order conversion" tool

Examples of PLT header content:

```
BEGIN LOADCASE_INDEX
  100010101 0 BCMESH 1 ORDER = 8.0
END LOADCASE_INDEX
```

```
BEGIN LOADCASE_INDEX
  1000 0 RPM = 1000.0
  5000 1 RPM = 5000.0
  9000 2 RPM = 9000.0
  13000 3 RPM = 13000.0
END LOADCASE_INDEX
```

Spectrogram Plot parameters

Spectrogram Plot reads the RPM or ORDER information from the input PLT file(s), merges the multiple PLT files (if any) and re-order the data per Order. The resolution of detection of the orders is 0.1 order.

The following input parameters are required (Figure 23.17):

- "Convention":
 - "Single PLT" containing all RPM or ORDER results

- or "Multiple PLT files" in case each RPM or ORDER is contained in separate a file
- Selection of PLT file(s)
 - "Input file": name of the PLT file for "Single PLT" convention
 - or "Input folder" path for "Multiple PLT files" convention. In this case all PLT files from the folder specified are imported
- "Final set name" helps choosing a name for the Orders set created (Default: AUTO)
- "Orders list" is the list of orders to import in the Orders set (Default: AUTO). It can be specified or modified manually.
- Button "Build Orders IDs" helps to detect the Orders available in input file(s). Optional. It is filling the "Orders list".
- Button "Build orders PLT set": create an Orders set in WaterfallViewer data tree

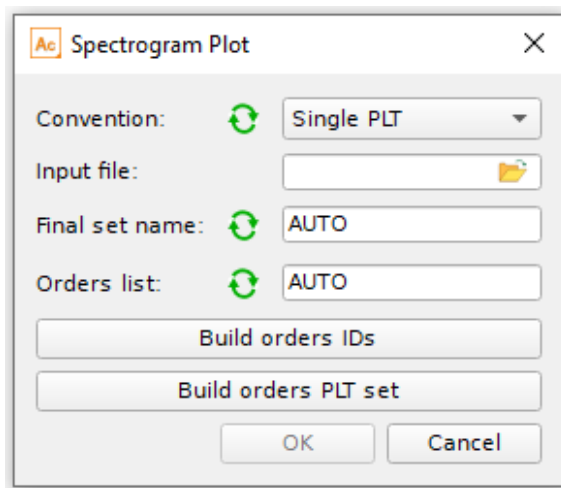

Figure 23.17: Input parameters for Spectrogram Plot

Spectrogram display

Once the Orders set is created, the user can plot a Spectrogram by right-clicking in the data tree (Figure 23.18). The quantity to plot and the operator to apply are chosen from the pop-up window (Figure 23.19).

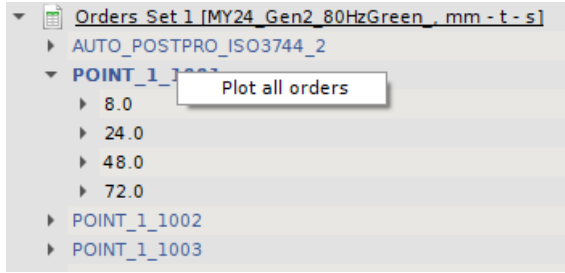

Figure 23.18: Right-click in data tree to plot a spectrogram

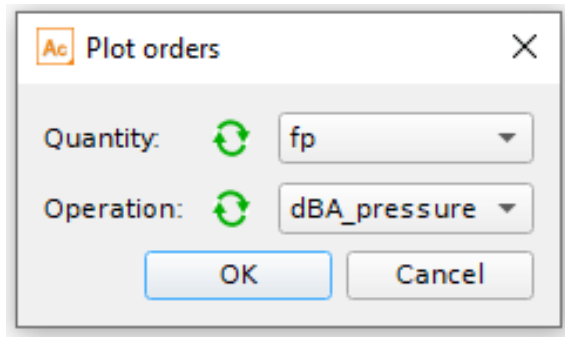

Figure 23.19: Selection of quantity and operator

The spectrogram is now displayed in the rendering window (Figure 23.20).

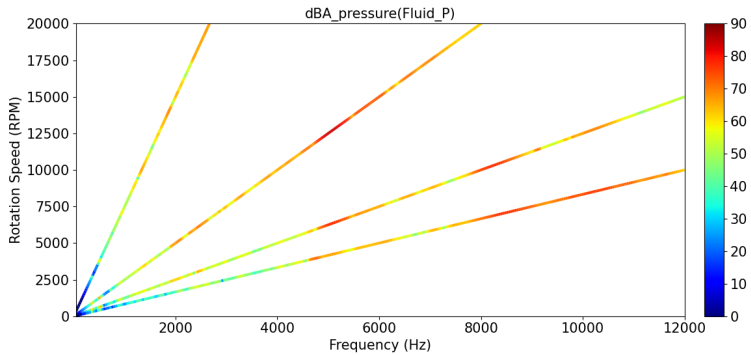

Figure 23.20: Spectrogram plot of SPL in dB at a FIELD_POINT

Information of frequency, RPM and Order value is available for any position of the mouse in the rendering window (Figure 23.21).

Frequency (Hz)=6520 Rotation Speed (RPM)=8150 dBA_pressure(Fluid_P)=64.2632 order=48.0

Figure 23.21: Information at mouse position

It is possible to plot any order as curve plot (Order over RPM or frequency) by extracting the order from the spectrogram (Figure 23.22).

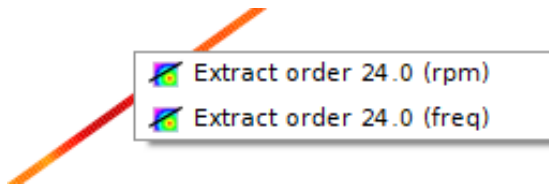

Figure 23.22: Right-click to extract an order as Cut plot over RPM or frequency

Finally the resolution of the display can be improved thanks to the interpolation option (Figure 23.23). The user provides a value of RPM step and each order is refined according to this value. Note that this option is only used for display purpose. It is not applied when exporting data from Spectrogram plot or Curve plot.

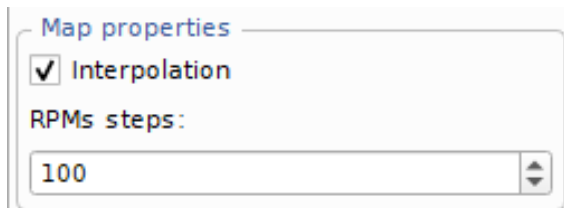

Figure 23.23: Interpolation option to smoothen the display along orders

23.2.5 EXTF tool

EXTF stands for EXcitation and Tranfer Function recombination. It is used to combine acoustic results (pressure) at field points with real excitations provided in time domain.

The EXTF window can be opened through menu Tools → EXTF (Figure 23.24).

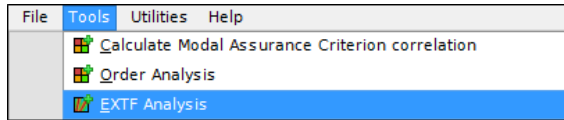

Figure 23.24: Opening the EXTF tool

The concept of the EXTF tool is the following:

1. A transfer function is computed with unit excitations and one or several loadcase(s);
2. Real excitations are provided in time domain and are dependent on RPM. EXTF computes the frequency spectrum of the excitations over RPM;
3. The EXTF tool combines excitation and transfer functions for each loadcase and sums loadcases together in the complex domain;
4. The EXTF tool displays and stores results.

Output results are the following:

- RPM\frequency diagram (waterfall) of Sound Pressure Level at dedicated field point
- SPL over time at dedicated field point

Drawing function can be selected among following choices: dB, Amplitude, Real, Imaginary, Phase.

Results are displayed in WATERFALLVIEWER but are also stored in the working directory of WATERFALLVIEWER current session:

1. Files used for DFT and DFT results of each excitation are available in the DFT directory;
2. DFT results of the excitations are stored as pictures and ASCII files in the CAMPBELL directory;
3. Recombined results are stored in the EXTF_RESULTS directory and contains:

- RPM\Frequency diagram for each field point selected according to the drawing function selected
- OSPL at each field point selected

A first dialog box asks for the transfer function file (PLT file) to be used (Figure 23.25). This file can contain one or several loadcases. Only pressure quantity at field points are considered for the EXTf tool.

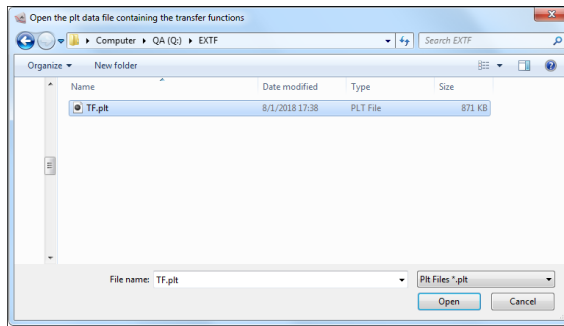

Figure 23.25: Transfer function file (PLT format) for EXTf calculation

Once the transfer function file is selected, a second dialog box (Figure 23.26) allows to choose the following options:

- The excitation files: An excitation file must be provided for each loadcase of the transfer function. The excitation file is a time domain dependent quantity. Its format should respect the following syntax:
 - 1st column: time
 - 2nd column: quantity (real, unit: consistent with transfer function loadcase)
- The RPM file: The RPM over time must be provided. Its format should respect the following syntax:
 - 1st column: time
 - 2nd column: RPM (real, unit: tr/min)
- The parameters for Discrete Fourier Transform (DFT). These parameters are detailed in Actran User's guide Volume 1, section ICFD:

- Time unit: if excitations and RPM are expressed in a unit different from 's', a unit factor can be applied
- Use existing DFT results: if user has already transformed excitation into frequency domain, the data stored in the directory of the PLT file can be used again. A warning message reminds the parameters of DFT used
- DFT Start - End - Interval - Overlap: defines parameters for mutli-time domain DFT.
- DFT Normalize - Window: allows to apply time domain windowing during DFT and normalize energy of the signal.
- Field points: Field points available in transfer function file are listed here. User can choose which field point must be used for recombination (single selection) or all field points ('All' selection)
- Drawing function: recombination results are displayed in WATERFALLVIEWER and PLTVIEWER using the selected drawing function. Results stored in the working directory are also using this drawing function.

Note that excitation files and RPM file must contain the same time series.

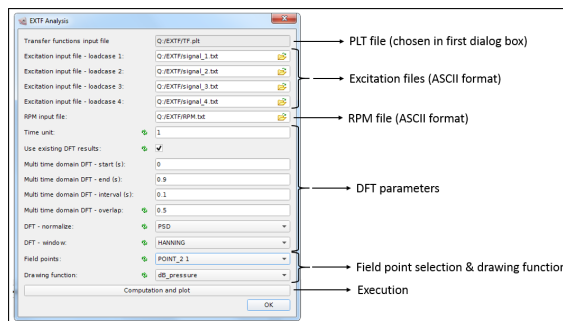

Figure 23.26: Main dialog box of EXTF tool

Typical results are displayed in Figures [23.27](#) and [23.28](#).

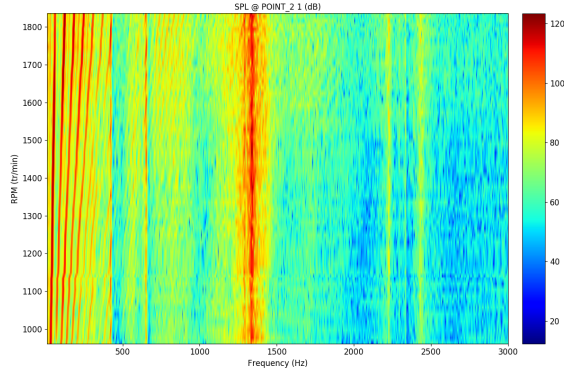

Figure 23.27: SPL in dB over RPM at field point POINT_2 1

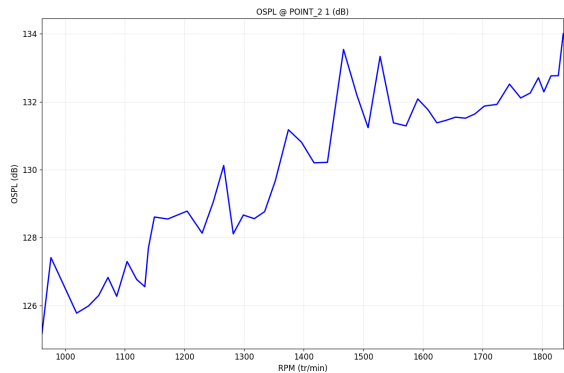

Figure 23.28: OSPL over RPM at field point POINT_2 1

23.2.6 RPM to Order conversion

The RPM to Order conversion window can be opened through menu Tools → RPM to Order conversion (Figure 23.29).

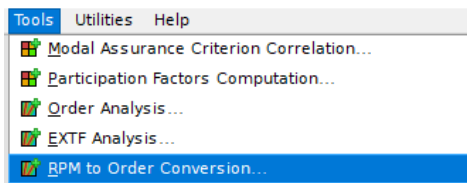

Figure 23.29: Opening the RPM to Order conversion tool

The RPM to Order conversion tool enables to reorganize Modal Participation Factors (MPF) obtained from simulations obtained at different rotation speeds (RPM) to Modal Participation Factors (MPF) organized by engine orders. This can be used to run an acoustic radiation analysis for all or selected orders.

Let's take an example. A Nastran structure dynamic analysis (Sol111) is performed for different subcases. Each subcase corresponds to a specific RPM value. Each subcase is run for frequencies selected at every 0.5 order:

- SUBCASE 1: 600 RPM, frequencies = 30, 60, 90, 120, 150... Hz
- SUBCASE 2: 3000 RPM, frequencies = 150, 300, 450, 600, 750... Hz
- SUBCASE 3: 6000 RPM, frequencies = 300, 600, 900, 1200, 1500... Hz
- ...

The participation factors for each subcase are exported as .pch format, either in a single file or in one file per RPM. The RPM to Order conversion tool helps to reorganize the PCH content by order so that the user can obtain MPF per order:

- Order 0.5, frequencies = 30, 150, 300... using first frequencies of each subcase
- Order 1.0, frequencies = 60, 300, 600... using second frequencies of each subcase
- Order 1.5, frequencies = 90, 450, 900... ..
- Order 2.0, frequencies = 120, 600, 1200... ..
- Order 2.5, frequencies = 150, 750, 1500... ..
- ...

The ACTRAN acoustic radiation will then be able use these data. Each ACTRAN LOADCASE will now correspond to an engine order.

The interface (Figure [23.30](#)) helps to choose:

- The input parameters for selecting the input data
- The computational parameters
- The output parameters

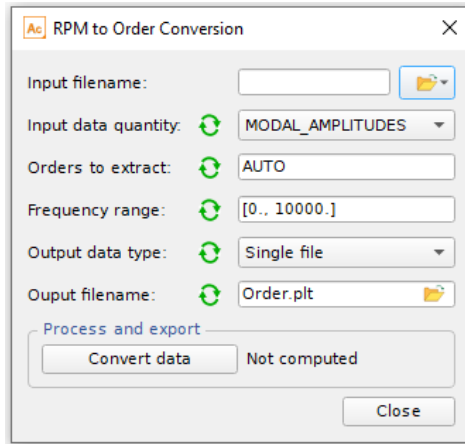

Figure 23.30: RPM to Order conversion tool interface

Input parameters:

- Input Filename (Figure 23.31):
 - Multiple Files: a master file (ASCII format) must be created to point to the input files (see below for the syntax of the master.txt file).
 - Single File: The user can choose directly the appropriate format among following: PLT (ACTRAN), PCH (Nastran), UNV

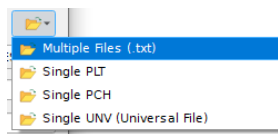

Figure 23.31: Options for Input filename

In case the Modal Participation Factors are stored in multiple files, one per RPM, the user must create a master.txt ASCII file defining the input files and associated RPM. The syntax of the master.txt file is the following:

- line 1: "name_of_rpm_file_1" rpm_value_1
- line 2: "name_of_rpm_file_2" rpm_value_2

- ...

In case the Modal Participation Factors are stored in a single file (PLT, PCH or UNV), the RPM values are supposed to be the internal loadcase ids.

- Input data quantity: MODAL_AMPLITUDES is the only choice. This corresponds to Modal Participation factors.

Computational parameters:

- Orders to extract:
 - AUTO: the orders are automatically detected based on frequencies available for each RPM. Note that only the common orders are extracted
 - list: the user can enter its own list to specify only a list of available orders. Example= [8.0, 22.3, 30.0]
- Frequency range: the frequency range can be limited to a user defined range. By default, the range is limited to [0., 10000.0] Hz.

Output parameters:

- Output data type:
 - Single file: Modal Participation Factors are stored in a single PLT file. Frequencies available for each order may be different. So the frequencies are merged. If a result does not exist for an order, the value 0.0 is assigned.
 - Multiple files: each order requested is stored in an individual PLT file. Each PLT file contains its own list of frequencies.
- Output filename: defines the name of the output file(s):
 - If Single file has been selected, the name of the PLT file is the filename.
 - If Multiple file has been selected, each PLT is using this filename with an extension corresponding to the value of each order.

Whatever the situation, the PLT file contains some information in the LOADCASE_INDEX block:

- ORDER = *order_value* is the value of order associated to a loadcase
- RPM = [rpm_1, rpm_2,...] is the list of RPMs corresponding to the frequencies for a given order

The ORDER information is reused by ACTRAN acoustic radiation analysis (BC_MESH) to transfer the information to the output results file. Hence the output PLT file keeps the information of ORDER associated to each LOADCASE.

- Convert data: runs the conversion and write the output files

23.2.7 1D Engine Source Coupling tool

The Engine Source coupling tool enables to evaluate engine sources based on output files provided by GT-Power. These sources can either be directly used inside the TMM (See Section ??) or recombined with a provided transfer function.

The definition of an engine source is described in Section 54.2.1 of Volume 1. The provided files from GT-Power are expected to be provided as follow:

- These should be provided as text files.
- They should either contain crank angle and both downstream and upstream pressure or source and impedance data.
- One file per RPM should be provided and named as 100RPM.txt for 100 RPM.

Two methods are available to evaluate the engine sources:

- A single configuration method that can only provide the amplitude of the source without reflection factor, as shown in Figure 23.32. In this configuration, the source files must all be provided in a single folder. This method is valid both for crank angle or source-impedance data inputs.
- A double configuration method that can provide the amplitude of the source with the corresponding reflection factor, as shown in Figure 23.33. In this configuration, it is expected to have both configurations provided in two separate folders names Config1 and Config2 respectively. The evaluation of both the source amplitude and reflection factor is then obtained as shown in Figure 23.34.

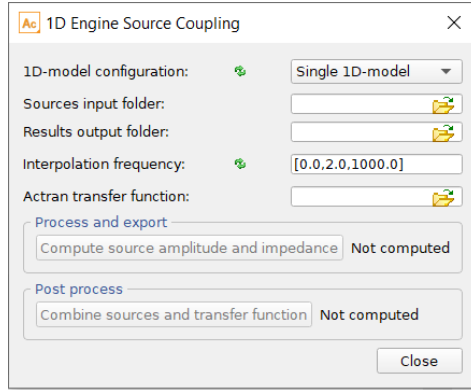

Figure 23.32: Single configuration window

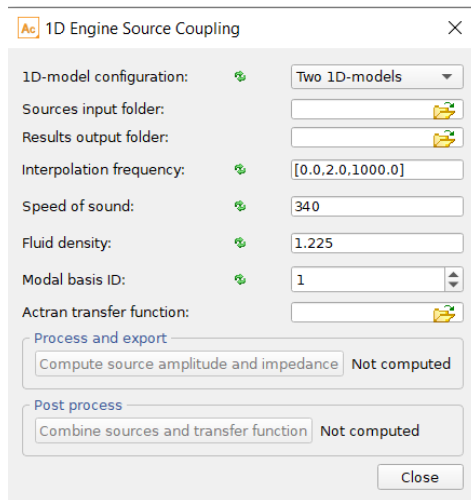

Figure 23.33: Double configuration window

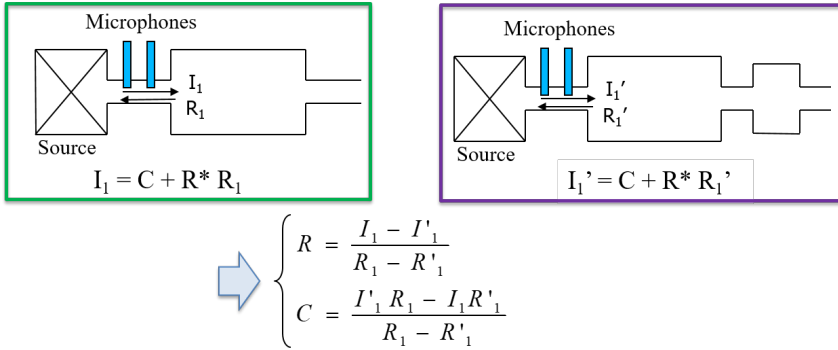

Figure 23.34: Double configuration source evaluation

In both configurations, the frequency domain of the evaluated sources, the output folder and the input folder must be provided. The evaluated engine source is then shown as in Figure 23.35.

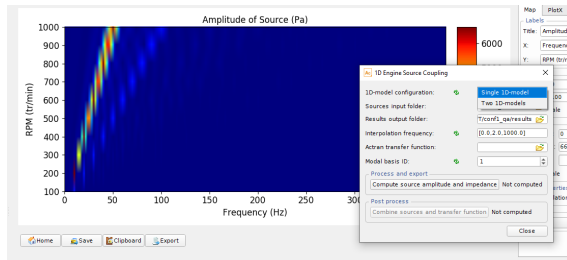

Figure 23.35: Double configuration source result

Optionally, the ACTRAN transfer function can be provided to enable a recombination using the evaluated sources. Both local indicators and radiated power will be recombined using the evaluated engine source. The recombination accounts for the source amplitude C and reflection factor R as follows:

$$P = \frac{TF * C}{1 - R * I_{MB}} \tag{23.3}$$

WATERFALLVIEWER Data Trees

24.1 Introduction

The Data tree panel of the WATERFALLVIEWER tool is similar to the Data tree panel of the PLTVIEWER tool (see Section 18).

The data tree contains all quantities imported from PLT, UNV PUNCH or TXT file. When the data is imported from the file, the results are automatically parsed and subdivided in different sections, depending on the type of imported file.

In general, the WATERFALLVIEWER will access tables of results (depending on loads and frequency) for generating functions and plots.

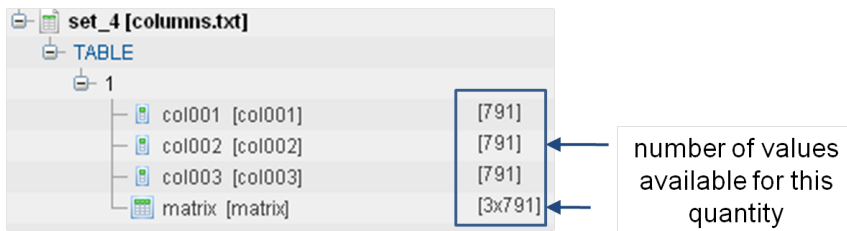

Figure 24.1: Indicator length.

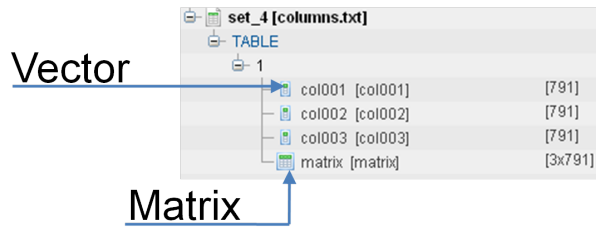

Figure 24.2: Vector and Table quantity.

WATERFALLVIEWER Function Panel

25.1 Introduction

In order to plot imported data to a figure, functions must first be created. A function associates pairs of arguments (X,Y) to acoustic values (Z). By convention, the set of X values represent the frequency and the set of Y values represent the regimes even if any other physical quantity can be associated to the X and Y arguments. Functions can be created by drag-and-dropping data from the tree to the X data vector or Y data vector or Z data table as shown below.

25.2 X and Y Vectors

The size of the X and Y vectors must be relevant compared to the size of the table that is used for the Z axis. If the Z table is of the size (m x n), the length of the Y vector should be m and the length of the X vector should be n.

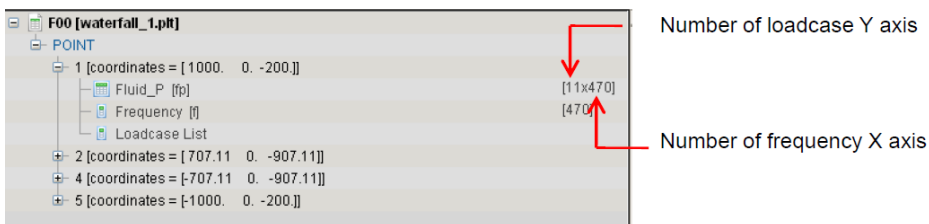

Figure 25.2: Size of the X and Y axis.

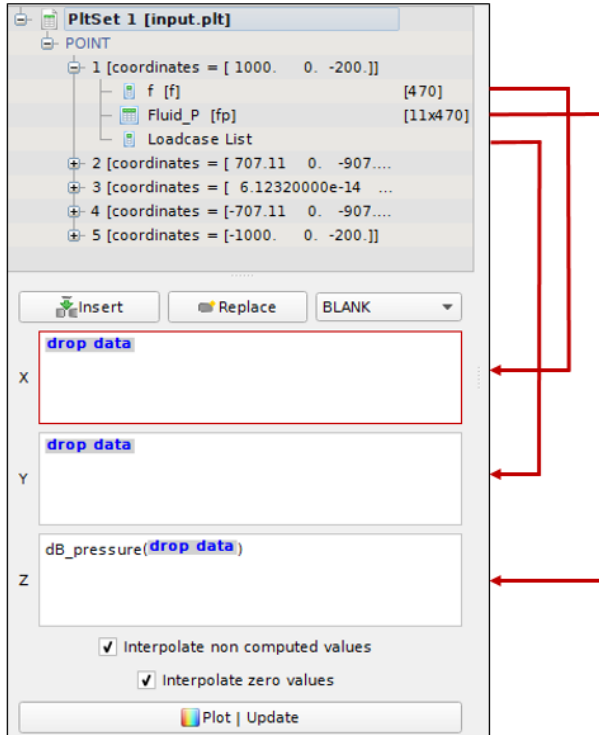

Figure 25.1: Functions of the Waterfall Viewer.

For multiple loadcases analysis, the loadcase List quantity has the right size to be defined as the Y vector and the frequency list quantity has the right size to be defined as the X vector.

The loadcase list may contain inappropriate values when the automatic loadcase generation mechanism of ACTRAN is used (please refer to the ACTRAN User's Guide, Section 11.22 of Volume 2). In this case, the user can define directly the Y vector by using python code such as the function `numpy.arange(min,max,step)`. If the user wants to define the Y axis as 11 values starting from 1 up to 11, he can directly introduces `numpy.arange(1,11,1)` in the Y axis input.

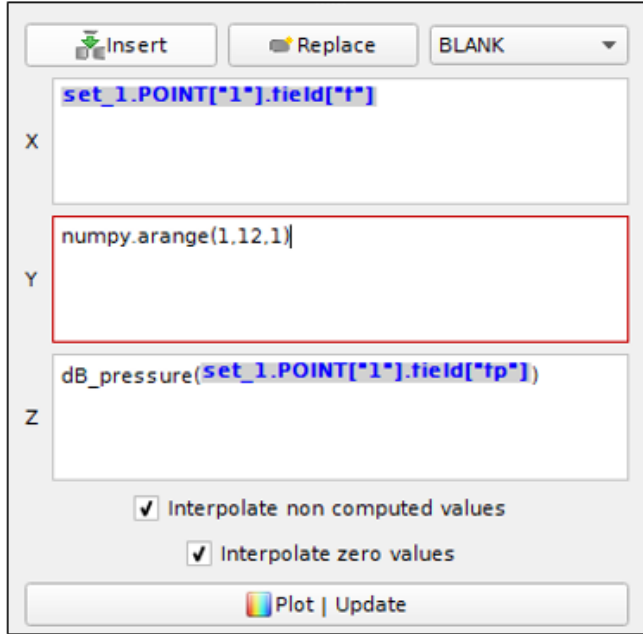

Figure 25.3: User-defined Y axis.

25.3 Z Table

The Z values must be dragged and dropped from a table of the data tree panel inside a data container. These data containers are available when selecting an operator as shown in Figure 25.5.

25.4 Function Definition

Data arrays can be combined by using operations.

For example : $20 \log\left(\frac{\sqrt{\text{Re}(p)^2 + \text{Im}(p)^2}}{2 \cdot 10^{-5} / \sqrt{2}}\right)$

becomes :

$20 \cdot \log_{10}(\text{sqrt}(\text{array}.\text{real}**2 + \text{array}.\text{imag}**2) / 2e-5 / \text{sqrt}(2))$

Another example, the velocity amplitude in a node, expressed in dB with a reference of 1:

$20 \log(\omega * \sqrt{\text{Am}(\text{Dis}_x)^2 + \text{Am}(\text{Dis}_y)^2 + \text{Am}(\text{Dis}_z)^2})$

becomes in the WATERFALLVIEWER:

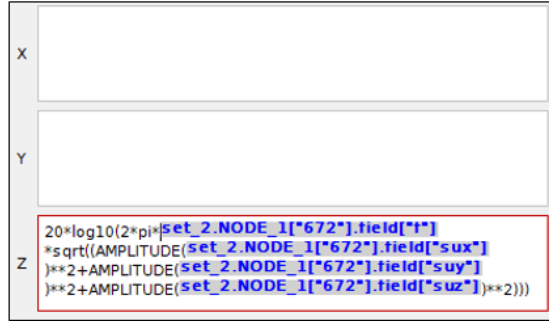

Figure 25.4: Definition of a function in the data vector.

A set of built-in operators is available in WATERFALLVIEWER and can be used in the definition of functions(see Figure 25.5).

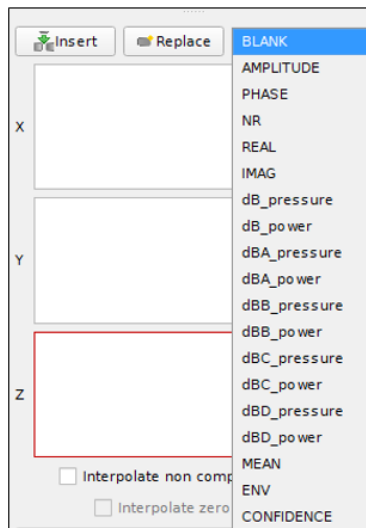

Figure 25.5: In-built operators.

The list of the different operators that are available and their description is provided in Table 19.1.

Please note that the language used for the data vector is the Python language (www.python.org). The mathematical python package used is Numpy (www.numpy.org).

25.5 Remarks and Further Reading

The check box "Interpolate non computed values" allows replacing all the NaN values available in Z-axis table, by values obtained by linear interpolation of nearest available values. Similarly, "Interpolate zero values" forces WATERFALLVIEWER to replace zero values by values using a linear interpolation of the nearest non-zero values. The function panel is not used for Spectrogram Plot (section [23.2.4](#)).

WATERFALLVIEWER **Render Window**

26.1 Introduction

The render Window is used to plot the functions defined in the function panel. This panel is organized in 4 sub-panels:

- Waterfall sub-panel;
- Horizontal Plot sub-panel;
- Vertical Plot sub-panel;
- Figure Properties sub-panel.

26.2 Waterfall Panel

A waterfall diagram is plotted in the waterfall panel. By right-clicking on the diagram one can create horizontal or vertical cut as illustrated in [Figure 26.1](#).

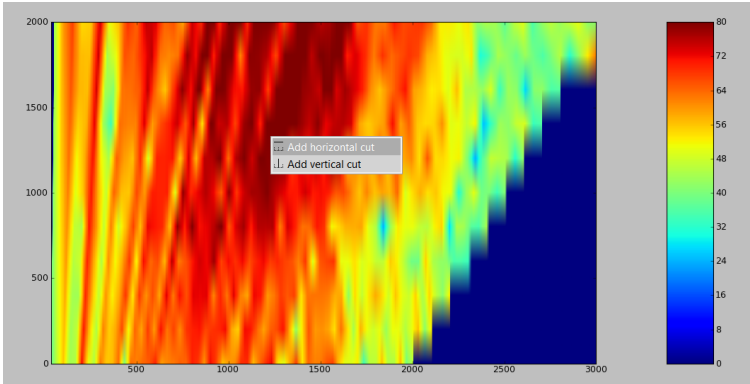

Figure 26.1: Add horizontal and vertical cut

Once created, the location of the vertical or horizontal cut can be edited by dragging the line using left-click. One can also change the line properties by right-clicking on the line (see Figure 26.2). The following properties can be edited:

- color
- marker
- line width
- line style

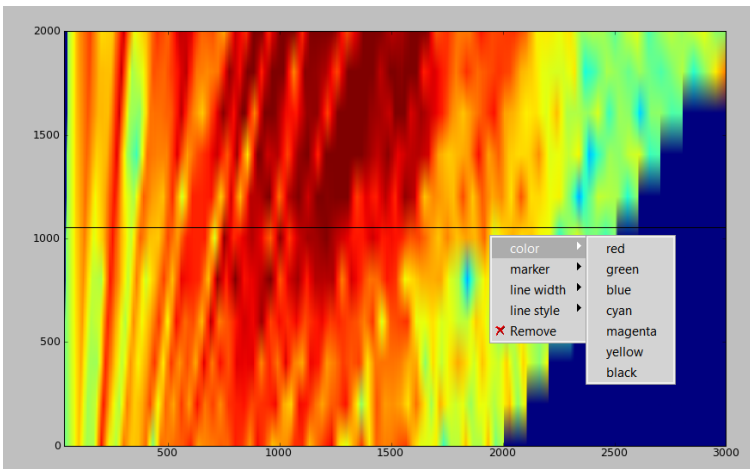

Figure 26.2: Vertical Horizontal Cut Line Properties

26.3 Horizontal and Vertical Plot Panel

Horizontal (and vertical) Plot Panel gathers all the horizontal (and vertical) cuts defined in the waterfall panel. The curves properties (color, marker, line width, line style) are identical to the ones defined in the waterfall panel.

Below the horizontal (and vertical) panel, the control bar (see Figure 26.3) is used to perform the following operations (ordered according to the buttons from left to right in the control bar):

- home: zoom out to fit all data in the figure.
- save the figure in various image file format such as png or eps.
- copy to clipboard allows to perform a snapshot of the displayed figure.
- export allows to output figure quantities in txt or csv formats.

Clicking on these buttons changes the mouse click behaviour and actions. To restore the original mouse click behaviour, the user should click a second time on the button.

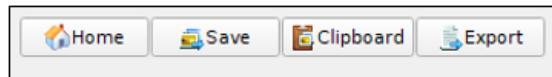

Figure 26.3: Figure Control Bar

26.4 Figure Properties Panel

The Figure Properties Panel allows defining the X, Y and Z axis label. One can also define the upper and lower bound of the color bar and the axis to be visualized.

The interpolation or discretization of the main map can be modified. De-activating the interpolation will show the raw discrete data along all directions. Activating a selective discretization along a particular direction allows to visualize different loadcases between them inside a single render window. This is useful when looking at mode contribution for example.

Map PlotX PlotY

Labels

Title: Map

X: X

Y: Y

Axes

X limits: 0 0 Log

Y limits: 0 0 Log

Autoscale

Colorbar

Min. value: 0

Max. value: 0

Unit:

Log scale

Map properties

Interpolation

Discretization along Y axis

Fonts

Color: k Size: 12

Figure 26.4: Render window properties

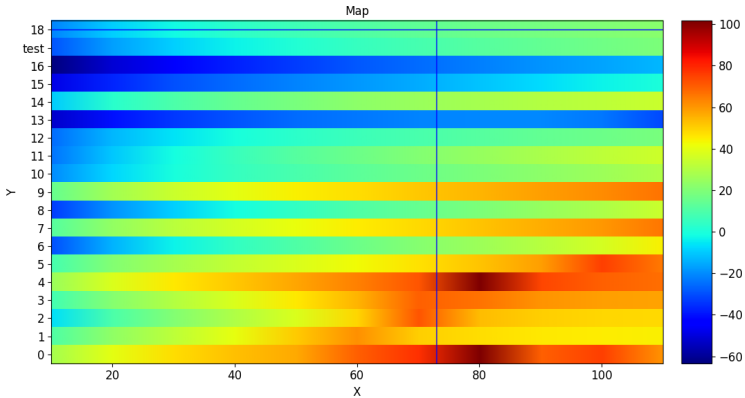

Figure 26.5: Discretization along a particular axis

Part V

Sessions and Scripting

Twenty Seven

Sessions

27.1 Purpose

During any instance of ACTRANVI, PLTVIEWER or WATERFALLVIEWER, a session file is automatically written in the current `report` folder. Every action performed interactively in the user interface (with a limited number of exceptions) is recorded in this session file using the ACTRAN Application Programming Interface (API). Please refer to chapters [29](#) and [30](#) for more details.

This session file can then be used for:

- Re-launching ACTRANVI, PLTVIEWER or WATERFALLVIEWER in the latest state;
- Retrieving a stable status of the application when an unexpected crash has occurred (removing faulty lines in the session file may be needed);
- Automating the creation, the run or the post-processing of an ACTRAN analysis.

27.2 Save Sessions

When opening ACTRANVI, PLTVIEWER or WATERFALLVIEWER, a session file is automatically created in the current `report` folder. The default name of this file is `ActranVI.0.sess`, whichever application has been opened.

Remark. *The previous sessions files existing in the current `report` folder are not overwritten. The number of the current session is increased to the first*

available number. For example, if `ActranVI.0.sess` exists, the session file created at the next start of ACTRANVI will be `ActranVI.1.sess`. If both `ActranVI.0.sess` and `ActranVI.2.sess` exist, the session file created at the next start of ACTRANVI will also be `ActranVI.1.sess`.

Each action performed in ACTRANVI, PLTVIEWER or WATERFALLVIEWER corresponds to a function of the API. For every user action, the corresponding API function is written:

- in the session file;
- in the console.

The session can be saved at any time by clicking

File → Export Session

in the main menu bar.

27.3 Load Sessions

At any time a session file can be loaded and played by clicking

File → Load Session ...

or

File → Load Recent Session ...

in the main menu bar.

When loading a session file, all the data currently defined (trees, display,...) are cleared. Two options are available to the user :

- Clear all data of the current application only (the current application corresponds to the one from which the session loading has been invoked), the data of the other opened applications not being deleted;

- Clear all data of all opened applications.

These two options are displayed in the "Load session options" dialog box that should appear after the session file chooser is closed.

This step is equivalent to the command (see Section 8.1.11):

File → Clear all trees

of the main menu bar.

Two different options are proposed to play a session file. The "Automatic Import" and "Interactive Import":

- Automatic import file(s): all files referred in the session file are imported automatically;
- Interactive import file(s): files referred in the session file are not imported automatically. Each time a command involving file import is read, the application explicitly asks the user to select the file. Therefore the user can select different files than those referred in the session file. This is useful for example to perform the same actions on another mesh.

27.4 Restrictions

Some actions have no equivalent function in the API and therefore are not recorded in the session file. These actions are :

- All the actions related to the selection of nodes, elements and [PID Domain](#);
- All actions related to [PID Domain](#) assignation modification (remove or add elements to new or existing [PID Domain](#), ...).

A pop-up window with a warning message is displayed when those actions are performed.

27.5 Remarks and Further Reading

- The user actions related to camera motions can be excluded from the session using the general settings (see Section 8.9).

- The session file is written in the PYTHON language (www.python.org) and can be enriched with any PYTHON function. Further details on the API are provided in the chapters [29](#) and [30](#).

Scripting

28.1 Introduction

In chapter 27, we detailed how to save and load a session to replicate all operations done in ACTRANVI, PLTVIEWER and WATERFALLVIEWER. This session feature rely on the link between every user action and the corresponding function of the ACTRAN Application Programming Interface (API).

This API defines a set of functions that take zero or more arguments that control its action. Those functions act on various objects, specific to each ACTRAN user-interface application.

- In ACTRANVI: viewport, material, analysis, component, boundary condition, domain, ...
- In PLTVIEWER: results set, figures, functions, curves, ...
- In WATERFALLVIEWER: results set, cuts, ...

These objects are often passed as arguments or returned by the functions of the API. The different properties that can be accessed for each object is specific to the object type. When an object is suppressed or overwritten, it is not accessible anymore.

The ACTRAN API allows the user not only to save and load sessions but also to create user-defined scripts, which is really powerful to automate pre- or post-processing operations. The script created can also include any module, function or command available in the PYTHON language.

This chapter aims at introducing the key concepts of the ACTRAN API and give the user the basics to build its own scripts.

28.2 Unified interface

Since release 14.0, ACTRANVI, PLTVIEWER and WATERFALLVIEWER can be used inside a single unified interface. Each application is opened in a tab, allowing to quickly switch from one application to the other. There remains one common console and log window for all three applications. Objects of each application can be created as soon as an application is opened in the unified interface, and are accessible from all applications through the common console terminal.

28.3 How to get help within the console

28.3.1 Help on API functions

As the number of functions is large, only the most useful ones are described in this chapter. The help on the most specific ones can be accessed directly from the console in ACTRANVI (see [11.5](#)).

To retrieve the list of all the functions (and their arguments) for each utility, the user can type one of these three commands within the console:

```
>> actranvi.help()
>> pltviewer_1.help()
>> waterfallviewer_1.help()
```

The user can restrict the display to the functions names containing only a given string with the command:

```
>> actranvi.help('string')
>> pltviewer_1.help('string')
>> waterfallviewer_1.help('string')
```

For example, to get the list of ACTRANVI functions containing the string *bc*:

```
>> actranvi.help('bc')
```

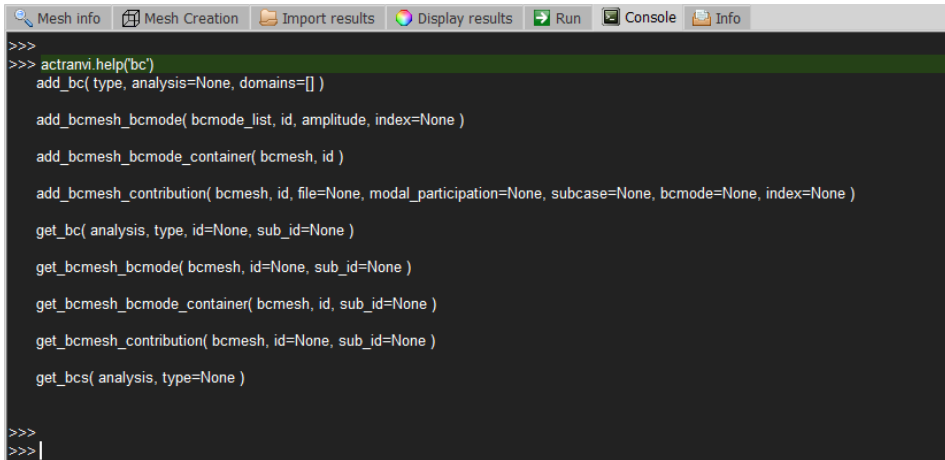

```

>>>
>>> actranvi.help("bc")
add_bc( type, analysis=None, domains=[] )

add_bcmesh_bcmode( bcmode_list, id, amplitude, index=None )

add_bcmesh_bcmode_container( bcmesh, id )

add_bcmesh_contribution( bcmesh, id, file=None, modal_participation=None, subcase=None, bcmode=None, index=None )

get_bc( analysis, type, id=None, sub_id=None )

get_bcmesh_bcmode( bcmesh, id=None, sub_id=None )

get_bcmesh_bcmode_container( bcmesh, id, sub_id=None )

get_bcmesh_contribution( bcmesh, id=None, sub_id=None )

get_bcs( analysis, type=None )

>>>
>>> |

```

Figure 28.1: List of API functions containing the string *bc*

28.3.2 Help on ACTRANVI objects and particular functions

For any object or function, the complete list of its properties can be obtained by typing the following command within the console:

```
>> help(object_name)
```

Remark. *object_name* is the name of the object as defined when created. For example the first fluid material created through the graphical user interface receives the name *fluid_material_1*.

The corresponding line in the console is :

```
>> fluid_material_1 = ...
... actranvi.add_material('Fluid Material')
```

For retrieving a help on a particular function, the application object must be specified:

```
>> help(actranvi.add_material)
```

Figure 28.2 shows an example of help returned for a material object of type Fluid Material:

```

>>> fluid_material_1.help()
- API type : 'Fluid Material'
- label radical : 'fluid'
- session radical : 'fluid_material'
- type :
  - label : 'Type'
  - values : 'Fluid Material'
    'Perfect Gas Material'
    'Water Material'
    'Isotropic Solid Material (Young-Poisson)'
    'Isotropic Solid Material (Lame)'
    'Transverse Isotropic Material'
    'Orthotropic Material'
    'Poroplastic Material (Young-Poisson)'
    'Poroplastic Material (Lame)'
    'Beam Material'
    'Stringer Material'
    'Spring Material'
    'Composite Solid Material (External Properties)'
    'Composite Solid Material (Layers)'
    'Sheet Material'
    'External Properties'
- optional : False
- syntax text : 'Type'
- name :
  - label : 'Name'
  - optional : False
  - syntax text : 'text'
- id :
  - label : 'Id'
  - optional : False
  - syntax text : 'an integer'
- sound_speed :
  - label : 'Sound Speed'
  - default_value : 340.0
  - quantity : 'SPEED_OF_SOUND'
  - values :
  - available_types :
  - optional : True
  - syntax text : 'A FIELD or a complex number or a TABLE + id entry (qty=SPEED_OF_SOUND)'
- fluid_density :
  - label : 'Fluid Density'
  - default_value : 1.2250000000000001
  - quantity : 'FLUID_DENSITY'

```

Figure 28.2: First line of the help return for a Fluid material object

The name of an object can also be retrieved by drag'n dropping the object from the main tree to the console as shown in Figure 28.3.

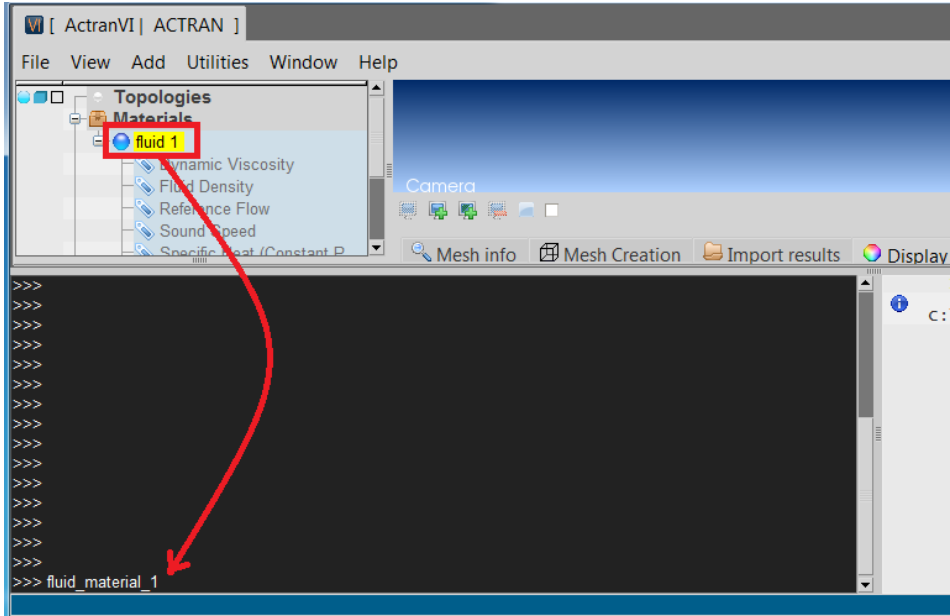

Figure 28.3: Retrieve object name with drag'n drop in the console

28.4 Remarks and Further Reading

Further informations about the PYTHON language can be found on <http://www.python.org/>.

ACTRANVI API

29.1 Main ACTRANVI pre-processing functions

Functions used during pre-processing are either available to edit or create new objects. In most cases, the type of the object (for instance, the type of a created material) can be set during the creation of the object, or edited later on. The main functions for pre-processing are listed in [Table 29.1](#).

29.2 Main ACTRANVI post-processing functions

The main post-processing functions are listed in [Table 29.2](#).

Function	Arguments	Description
read_mesh	file, file_format	Allows importing a mesh file and creating a main topology.
read_analysis	file	Allows importing an ACTRAN analysis.
read_material	file	Allows importing an ACTRAN material.
read_table	file	Allows importing an ACTRAN table.
reinterpolate	topology	Modifies the interpolation order of an existing topology.
add_domain	topology	Creates a new domain.
auto_create_domain	pid	Creates a new domain from an existing pid.
auto_create_domains	topology	Creates a new domain from every existing pid in a topology.
add_viewport	-	Creates a new viewport.
add_material	type	Creates a new material.
add_table	type	Creates a new table.
add_analysis	type	Creates a new analysis.
add_bc	analysis,type	Creates a new boundary condition.
add_component	analysis,type	Creates a new component.
add_	analysis	Creates a new object of the specified type.
get_	type, name, id	Finds a specified object type based on his pid, type or name.
add	target, source	Assigns to a target (being any kind of object) a source (being a mesh, ...).
set_prop	object, property	Sets the property of a selected object to a specified value.
validate	analysis, arguments	Validates an analysis by a test run using the specified arguments.
run	analysis, options, arguments, clean_scratch	Runs the computation of an analysis using the specified options and arguments.
write_analysis	analysis, file, format	Exports an ACTRAN input file from an analysis.
clear_all	-	Clean the whole content of ACTRANVI.
quit	force	Closes the current session (force allows removing the confirmation popup)
centercb	-	Calculate the center and 1st axis of a modal duct (This is a function of the modal duct).
axiscb	-	Calculate the 2nd and 3rd axes of a modal duct (This is a function of the modal duct).
paramcb	-	Calculate the other geometry parameters of a modal duct (This is a function of the modal duct).

Table 29.1: ACTRANVI functions for pre-processing.

Function	Arguments	Description
read_mesh	file, file_format	Allows importing a mesh file and creating a main domain.
add_viewport	-	Creates a new viewport.
add_result_file	mesh, file, sub_type	Reads the content of a result file and creates a container to access those.
add_cut	-	Create a new cutplane object.
import_results	result_container, quantity	Imports the selected quantity from the result_container in the current session.
display_map	operator, quantity	Displays a map of the selected quantity using the selected operator.
display_deform	operator, quantity	Displays a deformation of the selected quantity using the selected operator.
display_iso_surfaces	operator, quantity	Displays isosurfaces of the selected quantity using the selected operator.
display_vectors	operator, quantity	Displays vectors of the selected quantity using the selected operator.
set_prop	object, property	Sets the property of a selected object to a specified value.
remove_all_display	-	Removes all visible visualizations.
cut_display	cut	Activates the visualization of the selected cutplane.
remove_cut_display	cut	De-activates the visualization of the selected cutplane.

Table 29.2: ACTRANVI functions for post-processing.

PLTVIEWER API

30.1 Access to results within ACTRAN results file

ACTRAN results file contains different arrays, representing different local or global quantities on points, domains or surfaces, for every loadcase. These are ordered in a tree within PLTVIEWER. All these result quantities can be easily accessed using the API functions.

The ACTRAN results file can be considered as an object (a set), which contains sub-objects (domains, points, ...). These objects contain themselves sub-objects (called fields, such as fluid pressure, ...). These sub-objects can contain multiple results (depending on the number of loadcases). This succession of objects is shown in Figure 30.1. Each object or sub-object can be called by its identifier, being a string or integer. The identifiers correspond to the identifiers of the ACTRAN result file, as described in the ACTRAN User's Guide.

For instance, the mean square pressure of the acoustic domain of Id 1 can be accessed using the following command:

```
fluid_pressure = set_1.domain["Acoustic1"].field["mp"].lc[1]
```

where `fluid_pressure` is an array. This value can be also retrieved by alternative ways, for example through the definition of other objects:

```
acoustic_domain = set_1.domain["Acoustic1"]  
fluid_pressure = acoustic_domain.field["mp"].lc[1]
```

where `acoustic_domain` represents the object containing all quantities related to

the selected domain.

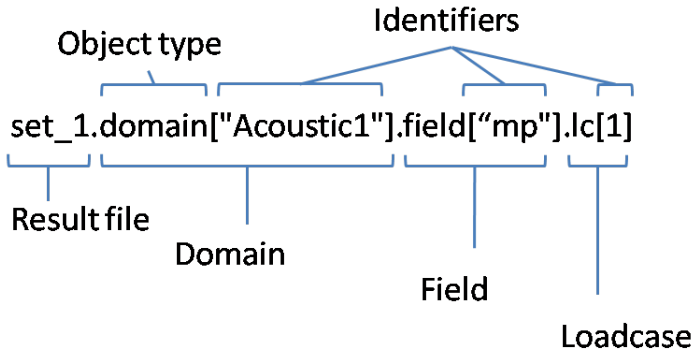

Figure 30.1: Content of the results objects

For each type of object, the list of sub-objects can be called by adding the `.ids` command to the object. For instance, calling the list of sub-objects on various quantities or domains provides:

```

>>> set_1.DOMAIN["Acoustic2"].ids
['f', 'mass', 'mp', 'sp', 'vol']
>>> set_1.ids
['DOMAIN', 'INTERFACE', 'POINT_1', 'POINT_2', 'SURFACE']
>>> set_1.SURFACE.ids
['CouplingSurface1', 'CouplingSurface2', 'SampledRandomDiffuse1']

```

The identifier of the selected object can be retrieved by adding the `.id` command to the object. For instance:

```

>>> point = set_1.POINT_1["1"]
>>> point.id
'1'

```

For modes, nodes and points, the comment present within the ACTRAN results file can be retrieved by adding the `.comment` command to the object. For instance:

```

>>> point = set_1.POINT_1["1"]
>>> point.comment
'coordinates = [ 0.5  0.  0. ]'

```

30.2 Main PLTVIEWER functions

The list of main PLTVIEWER functions is given in Table 30.1.

When creating new curves, figures or functions, it is advised to specify a name to the object, in order to call this object later in the script.

30.2.1 Examples

Plotting a curve

The default syntax for plotting a simple curve is the following:

```
set_1 = import_file(file=r'C:\test.plt',ftype='plt')
fig_1 = new_figure()
func_1 = new_func()
update_func(func=func_1,x=set_1.NODE["184"].field["f"],...
            ...y=REAL(set_1.NODE["184"].field["suz"]))
curve_1 = plot( function=func_1, figure=fig_1 , label='NODE 184' )
set_prop( fig_1, xlabel='f', ylabel='Solid_UZ (REAL)' )
```

The different properties of the curves, function and figures can be specified at the creation of the objects. The script above is equivalent to the same compact one:

```
set_1 = import_file(file=r'C:\test.plt',ftype='plt')
fig_1 = new_figure( xlabel='f', ylabel='Solid_UZ (REAL)')
func_1 = new_func(x=set_1.NODE["184"].field["f"],...
                 ...y=REAL(set_1.NODE["184"].field["suz"]))
curve_1 = plot( function=func_1, figure=fig_1 , label='NODE 184' )
```

Multiple curve creation

When adding different curves of the same type of value, the number of lines in the script can become important:

```
set_1 = import_file(file=r'C:\test.plt',ftype='plt')
fig_1 = new_figure( xlabel='f', ylabel='Solid_UZ (REAL)')
func_1 = new_func(x=set_1.POINT["1"].field["f"],...
                 ...y=REAL(set_1.POINT["1"].field["suz"]))
curve_1 = plot( function=func_1, figure=fig_1 , label='POINT 1' )
func_2 = new_func(x=set_1.POINT["2"].field["f"],...
                 ...y=REAL(set_1.POINT["2"].field["suz"]))
curve_2 = plot( function=func_1, figure=fig_1 , label='POINT 2' )
func_3 = new_func(x=set_1.POINT["3"].field["f"],...
                 ...y=REAL(set_1.POINT["3"].field["suz"]))
curve_3 = plot( function=func_1, figure=fig_1 , label='POINT 3' )
func_4 = new_func(x=set_1.POINT["4"].field["f"],...
                 ...y=REAL(set_1.POINT["4"].field["suz"]))
curve_4 = plot( function=func_4, figure=fig_1 , label='POINT 4' )
```

Since standard PYTHON syntax can be used, the size of the script can be reduced through the use of loops (for, while, ...) :

```
set_1 = import_file(file=r'C:\test.plt',ftype='plt')
fig_1 = new_figure( xlabel='f', ylabel='Solid_UZ (REAL)')
for point in set_1.point:
    func_1 = new_func(x=point.field["f"],y=REAL(point.field["suz"]))
    plot( function=func_1, figure=fig_1 , label='POINT '+point.id )
```

Please refer to the PYTHON documentation for more details.

Function	Mandatory inputs	Optional inputs	Description
import_file	file, ftype	-	Allows importing an ACTRAN results file
add_reverse_set	set	-	Creates a reverse set
rename_set	set, name	-	Renames the imported set
remove_plt_set	set	-	Removes a set
merge_sets	list of sets	title, tol, axisymmetric order, lc_offset_duct_mode, force_average	Merges multiple plt_sets
new_figure	-	figure object props	Creates a new figure in the graphical user interface
duplicate_figure	figure	-	Duplicates an existing figure
remove_figure	figure	-	Removes an existing figure
new_func	-	x,y	Creates a new function
update_func	func,x,y	-	Updates the existing x and y of an existing function
remove_func	func	-	Removes an existing function
plot	fig, func	label, line_color, line_style, marker_color, marker_style, opacity, thickness, type	Creates a curve with specified properties
remove_curve	curve	-	Removes an existing curve
set_prop	object	figure object props, curve object props	Sets the properties of objects (curves,...)
export_text	fig, filename	-	Exports the curves under txt format
convert_to_audio	-	plt_set, wavfilename, read_file, obj, loadcase, mono, window, maxlevel, length, df, interpolation, time	Converts an acoustic pressure frequency response to an audio file
export_image	fig, filename	width, height	Exports the curves under png format
clear_all	-	-	Clean the whole content of PLTVIEWER.
quit	-	force	Closes the current session (force allows removing the confirmation popup)

Table 30.1: PLTViewer functions.

Thirty One

WATERFALLVIEWER**API**

The list of WATERFALLVIEWER functions is given in Table [31.1](#).

Function	Mandatory inputs	Optional inputs	Description
import_file	file, ftype	-	Allows importing an ACTRAN results file
plot	x vector, y vector, z matrix	fig_set , interpolate_matrix, update_widgets	Creates waterfall diagram with specified properties
add_cut	plot , position	-	Adds a cut in the
remove_cut	cut	-	Removes an existing cut
export_text	fig, filename	-	Exports the WATERFALLVIEWER diagram under txt format
export_image	fig, filename	width, height	Exports the curves under png format
mac	geom_model_file, geom_model_format, modal_database_1_file, modal_database_1_format, modal_database_2_file, modal_database_2_format	frequency_range, gap_tol, plane_tol, one_dimension_modal_database	Computes the modal assurance criterion
participation_factors	results_file, results_format, modes_file, modes_format, mesh_file, mesh_format	frequency_range, gap_tol, plane_tol, modes_quantity, results_quantity	Computes the modal participation factors
clear_all	-	-	Clean the whole content of WATERFALLVIEWER
quit	-	force	Closes the current session (force allows importing the confirmation

Table 31.1: WaterfallViewer functions.

Part VI

Index

Index

ACTRANVI

- BOXPRO Topology, 153
- Analysis, 168
- Animation, 221
- BCmesh mode contribution, 227
- BCmesh split, 226
- Console, 225
- Cut-plane, 220
- Data tree panel, 123
- Display results, 213
- Elements selection, 233
- Field points, 255
- File chooser, 134
- Import results, 208
- Job launcher, 223
- Material, 160
- Material Encryption, 297
- Menu, 87
- Mesasure distance and angle, 196
- Mesh info, 196
- Mesh quality, 200
- Meshing tools, 245
- Partitions, 206
- Pole Fitting, 228
- Projection manager, 203
- Property window, 131
- Render window, 115
- Scope selector, 136
- Settings, 104
- Table, 164
- Toolbox, 195
- Topology tree, 141
- UGUI, 85
- USConversion, 292
- Utility analysis, 192
- UUS, 287

Viewport, 117

Visual tree, 193

PLTVIEWER

- Data tree panel, 313
- Function panel, 325
- Menu, 307
- Render window, 339
- Sound Quality Metrics, 355

WATERFALLVIEWER

- Data tree panel, 393
- Function, 395
- Menu, 365
- Render window, 401

API

- ACTRANVI, 417
- PLTVIEWER, 421
- WATERFALLVIEWER, 427

Horn model example, 41

Launching ACTRANVI, 35

Sessions, 407



Hexagon is a global leader in sensor, software and autonomous solutions. We are putting data to work to boost efficiency, productivity, and quality across industrial, manufacturing, infrastructure, safety, and mobility applications. Our technologies are shaping urban and production ecosystems to become increasingly connected and autonomous – ensuring a scalable, sustainable future.

Hexagon develops and supports Actran, a powerful software suite for acoustic, vibro-acoustic and aero-acoustic modeling. Actran contains a wide set of acoustic features making it the solution of choice for customers as diverse as top car manufacturers and their suppliers, the largest civil and military aircraft and aircraft engine manufacturers, leading producers of loudspeakers and other audio devices, consultants, universities and research centers. <https://hexagon.com/solutions/acoustic-simulation>

Hexagon's Manufacturing Intelligence division provides solutions that utilize data from design and engineering, production and metrology to make manufacturing smarter. For more information, visit hexagonmi.com.

Hexagon (Nasdaq Stockholm: HEXA B) has approximately 20,000 employees in 50 countries and net sales of approximately 3.8bn